

**ITALY**

Viale Aldo Borletti, 61/63  
20011 Corbetta (Milano)  
Tel. +39 02 97227421 +39 02 97227807 • Fax +39 02 97227234

After Market Parts and Services S.p.A.  
Viale Carlo Emanuele II 150, 10078 Venaria (Torino)  
Tel. +39 011 6879356 • Fax +39 011 6879032  
www.magnetimarelli-checkstar.it

**Export**

Viale Aldo Borletti, 61/63  
20011 Corbetta (Milano) Italy  
Tel. +39/02/97227618 • Fax +39/02/97227755

**SPAIN**

Polígono Industrial G-2 Collsabadell  
Ronda de Collsabadell, 1-3  
08450, Llinars del Vallès, BCN  
Tel. +34/93/8413530 • Fax +34/93/8427257

**FRANCE**

Z.A. Trappes Elancourt  
5-7 rue Albert Einstein - 78190 Trappes  
tel +33 (0)1 3016 6960 - Fax +33 (0)1 3016 6961

**GERMANY**

Wannenäckerstrasse 71  
74078 Heilbronn  
Tel. +49/7131/2910 • Fax +49/7131/165236

**POLAND**

Plac pod Lipami 5  
40-476 Katowice  
Tel. +48/32/6036107 • Fax +48/32/6036108

**BRAZIL**

Rua Manoel da Nóbrega, 350  
09380-120 Mauá-São Paulo  
Tel. +55/11/45191717 • Fax +55/11/45191688

**ARGENTINA**

R. Andonaegui 1035  
(C1427BEC) Capital Federal-Buenos Aires  
Tel. +54/11/45236612 • Fax +54/11/45236613



2011

**Candelette di preriscaldamento**  
**Glow plugs**  
**Glühkerzen**  
**Bougies de préchauffage**  
**Bujías de precalentamiento**  
**Velas de pre-aquecimento**  
**Προθερμαντήρες**  
**Świece żarowe**  
**Свечи накаливания**  
**Ön ısıtma bujileri**

**Magneti Marelli After Market Parts and Services S.p.A.**

Viale Aldo Borletti, 61/63 - 20011 Corbetta (Milano) Italia  
Tel. +39 02 97227421 +39 02 97227807 - Fax +39 02 97227234  
www.magnetimarelli-checkstar.com

**Legenda**      **Leyenda**      **Легенда**  
**Legend**      **Legenda**      **Gösterge**  
**Erläuterung**      **Ευρετήριο**  
**Légende**      **Legenda**

	Costruttore e modello / Make and model / Hersteller und Modell / Modèle / Constructor y modelo / Montadora e modelo / Μάρκα και οντέλο / Producent i model / Сделано и оделировано / Üretici ve model
	Numero cilindri / Number of cylinders / Anzahl der Zylinder / Nombre de cylindres / Numero de cilindros / Número de cilindros / Αριθμός κυλίνδρων / Liczba cylindrów / Количество цилиндров / Silindir sayısı
<b>kW</b>	Potenza motore / Engine power / Motorleistung / Puissance moteur / Potencia motor / Potencia do motor / Ισχύς κινητήρα / Мощность двигателя / Motor gücü
	Motore / Motor / Motor / Moteur / Motor / Motor / Κινητήρας / Motor / Мотор / Motor
	Anno di produzione / Manufacturing year / Baujahr / Date de fabrication / Año de fabricación / Ano de fabricaçao / Έτος παραγωγής / Rok produkcji / Год изготовления / Üretim yılı
	Codice Magneti Marelli / Magneti Marelli Reference / Magneti Marelli Nr. / Référence Magneti Marelli / Código Magneti Marelli / Código Magneti Marelli / Κωδικός Magneti Marelli / Kod Magneti Marelli / Коды Magneti Marelli / Magneti Marelli Şifreleri
	Intercambiabile con / Interchangeable with / Austauschbar mit / Interchangeable avec / Intercambiabile con / Intercambiable con / Εναλλάξιμο με / Устанавливается / Взаимозаменяемо с / aşığıdaki ürünlerle değıştirilebilir
<b>Amp</b>	Corrente assorbita alla temperatura di funzionamento / Current at working temperature / Ampere / Consumption de courant à la température de fonctionnement / Corriente a la temperatura de funcionamiento / Corrente à temperatura de funcionamento / Απορροφούμενο ρεύμα στη θερμοκρασία λειτουργίας / Pobór prądu w temperaturze funkcjonowania / Потребляемый ток при рабочей температуре / Çalışma ısısında çekilen akım miktarı
<b>V</b>	Tensione / Voltage / Spannung / Voltage / Voltaje / Voltagem / Τάση / Napięcie / Напряжение / Voltaj
<b>T A B c d</b>	Dimensioni candeletta / Glow plug dimensions / Gewindegröße / Dimensions de la bougie / Dimensiones de la bujía / Dimensões da vela / Διαστάσεις προθερμαντήρα / Wymiary świecy / Размеры свечей накаливания / Isıtma bujileri ebatları
<b>α</b>	Angolo di incidenza / Angle of incidence / Winkel des Kegeldichtsitzes / Angle d'incidence / Angulo de incidencia / Angulo de incidència / Γωνία κάστερ / Kąt widzenia / Угол конического посадочного места / Etkileme açısı
	Filettatura corpo candeletta / Glow plug body thread / Gewindemab / Filetage du corps de la bougie / Rosca del cuerpo de la bujía / Rosca del corpo de la vela / Σπείρωμα σώματος προθερμαντήρα / Gwintowanie świecy / Резьба на корпусе свечи / Vidalama dişleri
	Chiave esagonale / Hexagonal size AF / Schlüsselweite / Clé à six pans / Llave hexagonal / Chave exagonal / Εξαγωνικό κλειδί / Klucz sześciokątny / Шестигранный ключ / Altıgen alyan anahtar
	Tempo di preriscaldamento / Preheating time / Vorglühzzeit / Temps de préchauffage / Tiempo de precalentamiento / Tempo de pre-aquecimento / Χρόνος προθέρμανσης / Czas podgrzewania / Быстродействие свечи / Ön kızdırma süresi
<b>Nm</b>	Coppia di serraggio / Torque / Anzugsdrehmoment / Couple de serrage / Pares de apriete / Dado de aperto / Ροπή σύφιξης / Moment dokręcania / Усилие закручивания / Sivata sikma tork değerleri

*Indice*

*Contents*

*Inhaltsverzeichnis*

*Sommaire*

*Indice*

*Indice*

*Περιεχόμενα*

*Spis treści*

*Содержание*

*Общие характеристики*

Indici costruttori/candele

Manufacturers/glow plugs index

Glühkerzen/Herstellerverzeichnis

Sommaires par marques et bougies

Indices constructores/bujías

Indices por montadoras/velas

Δείκτες κατασκευαστών/προθερμαντήρων

Indeksy producentów/świec

Указатель производителей/свечей накаливания

Üretici/buji indeksi

3/4

Caratteristiche generali

General specifications

Allgemeine Merkmale

Caractéristiques générales

Características generales

Características gerais

Γενικά χαρακτηριστικά

Cechy ogólne

Общие характеристики

Genel özellikler

9

Applicazione per marca e veicolo

Vehicle application guide

Zuordnung nach Marke und Fahrzeug

Affectations par marques et véhicules

Aplicación por marca y vehículo

Aplicação por marca e veículo

Εφαρμογή ανα μοντέλο

Zastosowanie dla marki i pojazdu

Применение

Marka ve otomobile göre uygulama

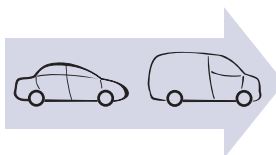

31

Applicazione per codice  
Buyers guide  
Zuordnung nach Bestellnummer  
Affectations par références  
Aplicación por código  
Aplicação por código  
Εφαρμογες ανα κωδικο  
Zastosowanie dla kodu  
Применение для кода  
Şifreye göre uygulama

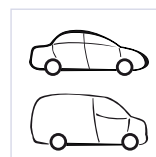

93

Tavole di comparazione  
Cross reference guide  
Gegenüberstellung  
Table de correspondance  
Tabla de equivalencias  
Tabela de equivalências  
Πίνακας αντιστοιχιων  
Tabela porównawcza  
Кросс-таблица  
Karşılaştırma



239

*Indice costruttori*  
*Manufacturers index*  
*Herstellerverzeichnis*  
*Sommaire par marques*  
*Indice constructores*  
*Indice por montadoras*  
*Ευρετήριο κατασκευαστών*  
*Indeks producentów*  
*Индекс изготовителей*  
*Üreticiler*

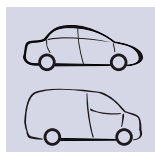

ALFA ROMEO	33	MERCEDES-BENZ	56
AUDI	34	MG	61
BMW	37	MINI	61
CHRYSLER	40	MITSUBISHI	61
CITROËN	40	NISSAN	62
DACIA	45	OPEL	64
DAEWOO	45	PEUGEOT	67
DODGE	45	RENAULT	71
FIAT	45	ROVER	75
FORD	49	SAAB	76
HONDA	52	SEAT	76
HYUNDAI	53	SKODA	79
ISUZU	53	SMART	80
JAGUAR	53	SSANGYONG	80
JEEP	53	SUZUKI	80
KIA	54	TOYOTA	81
LANCIA	54	VAUXHALL	82
LAND ROVER	55	VOLKSWAGEN	85
MAZDA	56	VOLVO	91

*Indice candelette*  
*Glow plugs index*  
*Glühkerzen*  
*Sommaire par bougies*  
*Indice bujías*  
*Indice por velas*  
*Δείκτης προθερμαντήρων*  
*Indeks świec*  
*Указатель свечей накаливания*  
*Buji indeks*

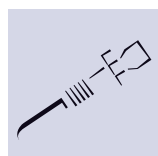

UC01F	94	UC35A	161	UY2A	215
UC02F	96	UC36A	163	UY3A	218
UC03F	99	UC37A	164	UY4A	221
UC04F	102	UC38A	166	UY5A	223
UC2A	103	UC39A	167	UY6A	225
UC4A	104	UC40A	168	UY7A	226
UC8A	106	UC41A	169	UY8A	228
UC9A	108	UC42A	171	UZ1A	230
UC10A	110	UC43A	172	UZ2A	232
UC11A	111	UC44A	173	UZ3A	234
UC12A	113	UC45A	174	UZ4A	235
UC14A	117	UX7A	177	UZ5A	237
UC15A	121	UX8A	178		
UC16A	123	UX11A	181		
UC17A	125	UX12A	183		
UC18A	128	UX13A	184		
UC19A	129	UX14A	186		
UC21A	133	UX16A	187		
UC22A	134	UX17A	188		
UC23A	136	UX18A	190		
UC24A	137	UX19A	192		
UC26A	138	UX20A	193		
UC27A	140	UX21A	204		
UC28A	142	UX22A	205		
UC29A	144	UX23A	206		
UC30A	146	UX24A	207		
UC31A	147	UX25A	208		
UC32A	158	UX26A	211		
UC33A	159	UY1A	212		

**I**

Magneti Marelli After Market Parts and Services S.p.A. ha curato con particolare attenzione la stesura del presente catalogo; declina comunque ogni responsabilità per eventuali errori od omissioni relativi a schemi, disegni, immagini, corrispondenze con i codici O.E. ecc. e si riserva il diritto di apportare modifiche al contenuto senza l'obbligo di darne preventiva comunicazione. Sono particolarmente graditi, da parte degli utenti, commenti, segnalazioni di inesattezze e qualsiasi altro suggerimento atto a rendere più efficace la prossima edizione del catalogo.

**GB**

Magneti Marelli After Market Parts and Services S.p.A. has devoted its best attention to the editing of this catalogue; it nevertheless declines any responsibility for possible mistakes or omissions regarding figures, drawings, pictures, correspondence with O.E. codes etc. and it reserves the right to modify the contents without prior notice. Users' comments, reports of inaccuracies or any other suggestions which may in any way improve the next edition of this catalogue are warmly welcomed.

**D**

Magneti Marelli After Market Parts and Services S.p.A. hat diesen Katalog sorgfältig verfasst. Die Firma enthebt sich jeglicher Verantwortung für eventuelle Fehler oder Auslassung hinsichtlich Schemen, Darstellungen, Zeichnungen. Übereinstimmung mit O.E. Codes usw. und behält sich das Recht vor, ohne Ankündigung, am Inhalt Veränderungen vorzunehmen. Anmerkungen, Fehlerhinweise und weitere Anregungen seitens der Kunden werden gerne entgegengenommen, um die nächste Ausgabe des Katalogs effizienter zu gestalten.

**F**

Magneti Marelli After Market Parts and Services S.p.A. a soigné avec une attention particulière la rédaction de ce catalogue; elle décline cependant toute responsabilité pour toute erreur ou omission éventuelle dans les schémas, les dessins, les images, les correspondances avec les codes O.E., etc. et se réserve le droit d'en modifier le contenu sans obligation de communication préalable. Les commentaires, les signalisations d'inexactitudes et toute autre suggestion des utilisateurs susceptibles de rendre la prochaine rédaction du catalogue plus efficace seront particulièrement appréciés.

**E**

Magneti Marelli After Market Parts and Services S.p.A. ha cuidado con especial atención la redacción del presente catálogo; de todas maneras declina toda responsabilidad por eventuales errores u omisiones relativos a esquemas, diseños, fotos, correspondencia con los códigos O.E., etc., y se reserva el derecho de aportar modificaciones al contenido sin la obligación de previo aviso. Se agradecen especialmente los comentarios, las indicaciones al contenido sin la obligación de previo aviso. Se agradecen especialmente los comentarios, las indicaciones de inexactitudes y cualquier otra sugerencia por parte de los usuarios que sean útiles para hacer más eficaz la próxima edición del catálogo.

**P**

A Magneti Marelli After Market Parts and Services S.p.A. cuidou com particular atenção a redação do presente catálogo; como quer que seja, rejeita qualquer responsabilidade face a eventuais erros o omissões relacionados aos esquemas, desenhos, imagens, correspondências aos códigos O.E. etc. e reserva-se o direito de introduzir alterações ao seu conteúdo sem a obrigação de comunicação prévia das mesmas. São particularmente bem aceitos, comentários, sinalizações de inexatidões e qualquer outra sugestão idónea a tornar mais eficaz a próxima edição do catálogo.

**GR**

Η Magneti Marelli φροντίσε με κάθε λεπτομερεια την ορθότητα των στοιχειων αυτου του καταλογου, δεν φερει ομως καμια ευθυνη για τυχον λαθη ή παραληψεις που σχετιζονται με σχηματα, σχεδια, εικόνες, αντιστοιχιες με γνησια νουμερα κτλ. και επιφυλασσειται του δικαιωματος να αλλαξει το περιεχομενο του καταλογου οποιαδηποτε στιγμή χωρις προτερη ενημερωση. Οποιαδηποτε σχολια η παρατηρησεις, με στοχο την βελτιωση του καταλογου, ειναι ευπροσδεκτα.

**PL**

Firma Magneti Marelli After Market Parts and Services S.p.A dołożyła szczególnych starań przy opracowywaniu niniejszego katalogu. Nie ponosi ona jednak żadnej odpowiedzialności za ewentualne błędy lub braki dotyczące schematów, rysunków, rysunki, zgodności z kodami O.E., itp. u. Firma Magneti Marelli After Market Parts and Services S.p.A zastrzega sobie prawo do wprowadzania zmian bez obowiązku uprzedniego powiadomiania o tym. Szczególnie mile widziane są komentarze i sygnały dotyczące nieprawidłowości oraz jakiegokolwiek inne sugestie zgłaszane przez klientów, mające na celu udoskonalenie następnych edycji katalogu.

**RU**

Magneti Marelli After Market Parts and Services S.p.A. уделило много времени и внимания редактированию этого каталога; Magneti Marelli After Market Parts and Services S.p.A. не несёт ответственности за возможные ошибки или упущения относительно фигур, рисунков, рисунки, сочетания с кодами O.E. и т.д. и резервирует право изменить содержание без предшествующего уведомления. Комментарии пользователей, сообщения погрешностей или любые другие предложения, которые, возможно, никогда не улучшают следующий выпуск этого каталога, тепло приветствуются.

**TR**

Magneti Marelli After Market S.p.A. Parts and Services, mevcut katalogdaki yazıyı çok özenli bir şekilde hazırlamıştır; O.E. vs. şifrelerine karşılık gelen her türlü model ve tasarım ile ilgili olası eksiklikler ve hatalar ile ilgili sorumluluğunun altını çizer ve öncesinde haber verme zorunluluğu olmaksızın değişiklik yapma hakkını saklı tutar. Kullanıcı tarafından yorumların, eksikliklerin ve her türlü önerilerin belirtilmesi, bir sonraki katalog baskısını daha etkili hale getirecektir.



**I**

È vietata la riproduzione, anche parziale, del contenuto del presente catalogo senza preventiva autorizzazione scritta della Magneti Marelli After Market Parts and Services S.p.A, che tutelerà i propri diritti a termine di legge.

**GB**

It is forbidden to reproduce, even partially, the contents of this catalogue without prior written consent from Magneti Marelli After Market Parts and Services S.p.A., who will protect its rights in accordance with the law.

**D**

Die Vervielfältigung, auch teilweise, des urheberrechtlich geschützten Inhalts des vorliegenden Katalogs ist ohne schriftliche Genehmigung durch Magneti Marelli After Market Parts and Services S.p.A. untersagt.

**F**

Il est interdit de reproduire même partiellement le contenu de ce catalogue sans autorisation écrite préalable de Magneti Marelli After Market Parts and Services S.p.A., qui protégera ses droits selon les termes de la loi.

**E**

Está prohibida la reproducción, total o parcial, del contenido del presente catálogo sin previa autorización escrita de Magneti Marelli After Market Parts and Services S.p.A, que protegerá sus propios derechos con arreglo a la ley.

**P**

É proibida a reprodução, também parcial, do conteúdo do presente catálogo sem a prévia autorização escrita de Magneti Marelli After Market Parts and Services S.p.A, que defenderá os próprios direitos, nos termos de lei.

**GR**

Απαγορευται η αναπαραγωγη, ολικη η μερικη, του περιεχομενου του παροντος καταλογου χωρις την γραπτη εξουσιοδοτηση της Magneti Marelli After Market Parts and Services S.p.A

**PL**

Zabronina jest nawet częściowa reprodukcja zawartości katalogu bez uprzedniej pisemnej autoryzacji ze strony firmy Magneti Marelli After Market Parts and Services S.p.A., która chroni swą własność zgodnie z przepisami prawa.

**RU**

Запрещается воспроизводить, даже частично, содержание этого каталога без предварительного письменного согласия от Magneti Marelli After Market Parts and Services S.p.A, которая будет защищать свои права в соответствии с законом.

**TR**

Tüm yasal hakların sahibi olan Magneti Marelli After Market Parts and Services S.p.A. 'in yazılı izni olmaksızın mevcut kataloğun kısmen de olsa çoğaltılması yasaktır.

La corrispondenza dovrà essere inviata a:  
Correspondence should be sent to:  
Der Briefverkehr ist zu senden an:  
Envoyer la correspondance à:  
La correspondencia debe ser enviada a:  
La correspondência deverá ser enviada a:  
Η αλληλογραφία θα πρέπει να αποσταλείται:  
Korespondencję należy przesyłać na adres:  
Соответствующую корреспонденцию просим  
присылать по адресу:  
Ticari yazışmalar şu adrese gönderilmelidir:

**Magneti Marelli After Market  
Parts and Services S.p.A.**

Viale Aldo Borletti, 61/63 – 20011 Corbetta (Milano) Italia  
Tel. +39 02 97227421 +39 02 97227807  
Fax +39 02 97227234  
[www.magnetimarelli-checkstar.com](http://www.magnetimarelli-checkstar.com)

*Caratteristiche generali*  
*General specifications*  
*Allgemeine Merkmale*  
*Caractéristiques générales*  
*Características generales*  
*Características gerais*  
*Γενικά χαρακτηριστικά*  
*Cechy ogolne*  
*Общие характеристики*  
*Genel özellikler*



## I

Magneti Marelli After Market Parts and Services ha realizzato una gamma completa di candele di preriscaldamento. La gamma si compone di 70 codici ed assicura la copertura del 90% del circolante europeo.

Tutte le candele di preriscaldamento Magneti Marelli sono provviste di doppio filamento e sono predisposte per restare accese fino a 3 minuti dopo l'avviamento del motore se la centralina lo richiede.

Progettate e realizzate secondo gli standard qualitativi dei maggiori costruttori europei, le candele di preriscaldamento Magneti Marelli garantiscono:

- ✓ Partenze a freddo ultra rapide anche in presenza di rigide condizioni ambientali
- ✓ Riduzione dei consumi e delle emissioni inquinanti
- ✓ Affidabilità totale
- ✓ Lunga durata

## GB

Magneti Marelli After Market Parts and Services has developed a comprehensive range of pre-heating glow plugs. The range comprises 70 item codes and covers 90% of the European vehicle fleet.

All Magneti Marelli glow plugs are equipped with double filament and are predisposed to remain operational for up to 3 minutes after engine ignition if the control unit requires so.

Magneti Marelli glow plugs are designed and made in accordance with the quality standards of major European manufacturers and guarantee:

- ✓ Ultra rapid cold starting even under adverse environmental conditions
- ✓ Reduced consumption and emission of pollutants
- ✓ Total reliability
- ✓ Long life

## D

## F

Magneti Marelli After Market Parts and Services a réalisé une gamme complète de bougies de préchauffage.

La gamme comporte 70 codes et assure la couverture de 90% des véhicules circulant en Europe.

Toutes les bougies de préchauffage Magneti Marelli comportent un double filament et sont prédisposées pour rester allumées jusqu'à 3 minutes après le démarrage du moteur si la centrale électronique le demande.

Conçues et réalisées en conformité avec les standards de qualité des principaux constructeurs européens, les bougies de préchauffage Magneti Marelli garantissent :

- ✓ Des démarrages à froid ultra-rapides même dans le cas de conditions de vie difficiles
- ✓ La réduction de la consommation et des émissions polluantes
- ✓ Une fiabilité totale
- ✓ Une longue durée de vie

## E

Magneti Marelli After Market Parts and Services ha creado una gama completa de bujías de precalentamiento.

La gama está compuesta de 70 códigos y garantiza la cobertura del 90% de vehículos circulantes en Europa.

Todas las bujías de precalentamiento de Magneti Marelli llevan un filamento doble y, si la centralita lo requiere, pueden permanecer encendidas hasta 3 minutos después de la puesta en marcha del motor.

Las bujías de precalentamiento Magneti Marelli, diseñadas y realizadas conforme a los estándares cualitativos de los mayores constructores europeos, garantizan:

- ✓ Arranques en frío inmediatos, incluso en condiciones climáticas muy duras
- ✓ Reducción de los consumos y de las emisiones contaminantes
- ✓ Fiabilidad total
- ✓ Larga duración

## P

A Magneti Marelli After Market Parts and Services realizou uma gama completa de velas de pré-aquecimento.

A gama é composta por 70 códigos e assegura a cobertura de 90% do parque circulante da Europa.

Todas as velas de pré-aquecimento Magneti Marelli são completas de duplo filamento e são predispostas para permanecer acesas até a 3 minutos depois do arranque do motor se a unidade central o solicitar.

Foram projectadas e realizadas de acordo com os standards qualitativos dos maiores fabricantes europeus, as velas de pré-aquecimento Magneti Marelli garantem:

- ✓ Partidas a frio ultra rápidas mesmo na presença de condições ambientais rígidas
- ✓ Redução dos consumos e das emissões poluentes
- ✓ Confiabilidade total
- ✓ Prolongada duração

**GR**

Η Magneti Marelli After Market Parts and Services υλοποίησε μία πλήρη γκάμα προθερμαντήρων.

Η γκάμα αποτελείται από 70 κωδικούς και εξασφαλίζει την κάλυψη του 90% των οχημάτων που κυκλοφορούν στην Ευρώπη.

Όλοι οι προθερμαντήρες Magneti Marelli διαθέτουν διπλό νήμα και μπορούν να παραμείνουν αναμμένοι έως και 3 λεπτά μετά την εκκίνηση του κινητήρα εάν δοθεί εντολή από τον εγκέφαλο.

Σχεδιασμένοι και κατασκευασμένοι με βάση τα ποιοτικά πρότυπα των μεγαλύτερων ευρωπαϊκών κατασκευαστών, οι προθερμαντήρες Magneti Marelli εξασφαλίζουν:

- ✓ Εξαιρετικά γρήγορες εκκινήσεις με κρύο ακόμα και σε ιδιαίτερα επιβαρυσμένες περιβαλλοντικές συνθήκες
- ✓ Μείωση της κατανάλωσης και της εκπομπής ρύπων
- ✓ Πλήρη αξιοπιστία
- ✓ Μεγάλη διάρκεια

**PL**

Spółka Magneti Marelli After Market Parts and Services opracowała kompletną gamę świec żarowych składającą się z 70 kodów i zapewniającą pokrycie 90% zapotrzebowania europejskiego.

Wszystkie świece żarowe Magneti Marelli posiadają podwójne uzwojenie i przystosowane są do świecenia aż do 3 minut po włączeniu silnika, jeśli wymaga tego jednostka kontrolna.

Świece żarowe Magneti Marelli, zaprojektowane i wykonane zgodnie ze standardami jakościowymi najważniejszych konstruktorów europejskich, gwarantują:

- ✓ Rozruch w niskich temperaturach, również w razie surowych warunków środowiskowych;
- ✓ Ograniczenie zużycia i emisji substancji zanieczyszczających;
- ✓ Całkowitą niezawodność;
- ✓ Długą żywotność.

**RU**

Служба послепродажного обслуживания и поставки запчастей фирмы Magneti Marelli (Magneti Marelli After Market Parts and Services) разработала полный спектр свечей накаливания из 70 наименований. Такой спектр обеспечивает 90 % покрытие потребностей европейского транспортного парка.

Все свечи накаливания, производимые фирмой Magneti Marelli, обладают двойной нагревательной спиралью и могут оставаться включенными вплоть до 3-х минут после запуска двигателя, если того требует блок управления двигателем.

Свечи накаливания фирмы Magneti Marelli разработаны и изготовлены в соответствии со стандартами системы управления качеством, применяемой всеми крупными европейскими производителями, и обеспечивают:

- ✓ Сверхбыстрый запуск холодного двигателя в суровых климатических условиях
- ✓ Снижение как потребления топлива, так и вредных выбросов
- ✓ Абсолютную надежность
- ✓ Длительный срок работы

**TR**

“Magneti Marelli After Market Parts and Services” geniş bir yelpazede ön kızdırma bujileri üretir.

Buji çeşitleri 70 kod türünü içerir ve Avrupa piyasasında bulunan çeşitlerin %90'ını kapsar.

Magneti Marelli'nin tüm ön kızdırma bujileri çift filamanlı ve kontrol ünitesi gerektirdiğinde motor çalıştırıldıktan 3 dakika sonrasına kadar kızgın kalmaları için yapılmıştır.

En büyük Avrupa imalatçılarının kalite standartlarına göre tasarlanıp gerçekleştirilen Magneti Marelli ön kızdırma bujileri aşağıdaki özellikleri taşımaktadır:

- ✓ Sert hava şartlarında da çok hızlı bir şekilde motor çalıştırmaları;
- ✓ Yakıt tüketimini ve egzoz emisyonlarını azaltmaları;
- ✓ Mükemmel bir güvenilirlik temin etmeleri;
- ✓ Uzun bir dayanıklılığa sahip olmaları.

## I

Per assicurare una copertura sempre più completa del circolante la gamma di candele Magneti Marelli si è arricchita di numerosi nuovi codici tra i quali le candele di nuova generazione con punta da **4mm**, le candele ceramiche e le nuovissime candele ultrafast a tensione variabile.

### Le candele CERAMIC

La nuova generazione di motori diesel, per soddisfare le normative sempre più esigenti in materia di inquinamento, ha reso necessario l'utilizzo di candele con performances più elevate che sono garantite dalla tecnologia ceramica.

Le candele ceramiche infatti, grazie alla loro capacità di restare accese più a lungo e di sopportare una temperatura di funzionamento più elevata, contribuiscono alla riduzione delle emissioni nocive e garantiscono il rispetto delle specifiche più rigorose. Esternamente le candele con bulbo ceramico sono simili alle candele con bulbo metallico; la differenza risiede nell'elemento riscaldante costituito da uno speciale materiale ceramico a base di nitruro di silicio che è dotato di una resistenza termica, all'usura, all'erosione e all'ossidazione superiore a quella delle leghe metalliche. Le performances delle candele ceramiche si distinguono perché:

- ✓ Hanno un ottimo tempo di pre-riscaldamento (3-4 s. max per raggiungere 850°C)
- ✓ Permettono di raggiungere senza subire danni temperature più elevate durante il post-riscaldamento (più di 1200°C mentre le candele metalliche possono arrivare a max 1000-1125°C)
- ✓ Possono restare accese fino a 10 minuti dopo l'accensione (le candele metalliche possono resistere accese fino a max 3 min).
- ✓ Assorbono minore potenza: meno di 40W nel post-riscaldamento mentre le metalliche lavorano tra i 70W e gli 80 W.

## GB

Many new codes have been added to Magneti Marelli's range to ensure complete and updated coverage of the car park. Among these the new **4mm**-point generation glow plugs, the ceramic glow plugs and the very latest variable tension ultra fast glow plugs.

### CERAMIC glow plugs

In line with stricter rules regarding pollution, the new generation of diesel engines requires the installation of higher performance glow plugs. Ceramic technology is the answer. Thanks to their capacity to remain operational longer and to resist higher working temperatures, ceramic glow plugs contribute in reducing harmful emissions and are in line with the strictest specifications. Seen externally, ceramic bulb

## D

Um den bestehenden Fahrzeugpark immer weiter und kompletter abzudecken wurde das Angebot der Glühkerzen aus dem Hause Magneti Marelli um eine Vielzahl an neuen Codenummern bereichert, unter denen sich auch die Glühkerzen der neuen Generation befinden, welche eine Kerzenspitze von **4mm** aufweisen, die Keramikglühkerzen und die allerneuesten Glühkerzen "Ultrafast" mit veränderlicher Spannung.

### Die CERAMIC Glühkerzen

Die neue Generation an Dieselmotoren macht aufgrund der immer strenger werdenden Umweltschutzbedingungen den Einsatz von Glühkerzen mit wesentlich höherer Leistungsfähigkeit notwendig, welche durch die Keramikktechnologie gewährleistet wird. Die Keramikglühkerzen tragen aufgrund ihrer Eigenschaft länger eingeschaltet bleiben zu können und eine höhere Betriebstemperatur zu haben, mit dazu bei den Ausstoß schädlicher Abgase zu verringern und garantieren somit das Einhalten der strengeren Abgasbestimmungen. Von außen betrachtet ähneln die Glühkerzen mit Keramikkolben denen mit Metallkolben; der Unterschied liegt im Heizelement, das aus einem speziellen Keramikmaterial auf Basis von Siliziumnitrid besteht, welches eine höhere Widerstandskraft gegen Hitze, Verschleiß, Erosion und Oxidation gegenüber den Metalllegierungen aufweist. Die Leistungen der Keramikglühkerzen unterscheiden sich aufgrund von:

- ✓ Optimaler Vorglühdauer (3-4 s. max. um 850°C zu erreichen)
- ✓ Erreichen von höheren Temperaturen beim Nachglühen (über 1200°C, während Metallglühkerzen maximal 1000-1125°C aushalten) ohne zu Schaden zu kommen
- ✓ Einschaltdauer von bis zu 10 Minuten nach Anlassen (Metallglühkerzen können maximal 3 Min. eingeschaltet bleiben).
- ✓ Geringere Leistungsaufnahme: weniger als 40 W beim Nachglühen, während Metallglühkerzen 70 W bis 80 W verbrauchen.

glow plugs are similar to those with a metal bulb; the difference lies in the heating element, made of a special silicon nitride based material, that has greater resistance to heat, wear and oxidation than metal alloys.

Characteristics of ceramic glow plug performance are:

- ✓ Optimum preheat times (max. 3-4s to reach 850°C).
- ✓ They reach higher temperatures without damage during postheating (over 1200°C while metal glow plugs reach 1000-1125°C max.).
- ✓ They can remain operational as long as 10 minutes after ignition (metal glow plugs can only resist on up to 3 min.).
- ✓ They absorb less power: less than 40W during postheating while metal glow plugs operate between 70 and 80W.

## F

Para garantir una cobertura siempre más completa del parque circulante, la gama de velas de precalentamiento Magneti Marelli se ha enriquecido con numerosos códigos nuevos, entre los cuales las velas de nueva generación con punta de **4mm**, las velas cerámicas y las más modernas velas "ultra fast" a tensión variable.

### Las velas de precalentamiento CERAMIC

Para satisfacer las legislaciones, siempre más exigentes en materia de contaminación, la nueva generación de motores diésel ha hecho necesario el uso de velas de precalentamiento cuyas prestaciones más elevadas son garantizadas por la tecnología cerámica. Gracias a su capacidad de permanecer encendidas más tiempo y a soportar una temperatura de funcionamiento más elevada, las velas de precalentamiento cerámico contribuyen en efecto a reducir las emisiones nocivas y garantizan el respeto de las especificaciones más rigurosas. Desde el exterior, las velas de precalentamiento de cerámica son similares a las de cerámica; la diferencia reside en el elemento calefactor, constituido por un material cerámico especial, a base de nitrato de silicio, dotado de una resistencia al calor, al desgaste, a la erosión y a la oxidación superior a la de las aleaciones metálicas.

- ✓ ellas tienen un excelente tiempo de precalentamiento (3 a 4 s máx para alcanzar 850 °C)
- ✓ el tiempo de precalentamiento les permite alcanzar temperaturas más elevadas durante el post-calentamiento (más de 1200 °C mientras que las velas metálicas alcanzan un máximo de 1000 a 1125 °C)
- ✓ ellas pueden permanecer encendidas hasta 10 minutos después del arranque (las velas de precalentamiento metálicas no pueden permanecer encendidas que hasta un máximo de 3 minutos).
- ✓ ellas absorben menos potencia: menos de 40 W durante el post-calentamiento mientras que las velas metálicas trabajan entre 70 W y 80 W.

## P

Para assegurar uma cobertura sempre mais completa dos veiculos em circulação a gama de velas Magneti Marelli se enriqueceu de numerosos novos códigos dentro os quais as velas de nova geração com ponta de **4mm** as velas cerâmicas e as novíssimas velas "ultra fast" por tensão variável.

### As velas CERAMIC

A nova geração de motores diesel, para satisfazer as normativas sempre mais exigentes em matéria de poluição, tornou necessário o uso de velas com performances mais elevadas que são garantidas pela tecnologia cerâmica.

As velas cerâmicas, de facto, graças à sua capacidade de permanecer acesas por mais tempo e de suportar uma temperatura de funcionamento mais alta, contribuem à redução das emissões nocivas e garantem o respeito das especificações mais rigorosas.

Externamente as velas com bulbo cerâmico são semelhantes as velas com bulbo metálico; a diferença reside

## E

Para assegurar una cobertura cada vez más completa del parque circulante, la gama de bujías Magneti Marelli se ha enriquecido con numerosos códigos nuevos, entre los cuales las bujías de nueva generación con punta de **4mm**, las bujías cerámicas y las más modernas bujías superrápidas de tensión variable.

### Las bujías de arranque CERAMIC

Las normas cada vez más exigentes para la reducción de la contaminación han impuesto, prácticamente, a la nueva generación de motores diésel la adopción de bujías de precalentamiento con prestaciones más elevadas, prestaciones que se obtienen con la tecnología cerámica.

De hecho, gracias a su capacidad de permanecer más tiempo encendidas y de soportar temperaturas de funcionamiento más elevadas, las bujías cerámicas contribuyen a reducir las emisiones nocivas y garantizan el respeto de las especificaciones más rigurosas.

Exteriormente, las bujías con bulbo cerámico son similares a las de bulbo metálico; la diferencia está en el elemento calefactor, constituido por un material cerámico especial, a base de nitrato de silicio, dotado de una resistencia al calor, al desgaste, a la erosión y a la oxidación superior a la de las aleaciones metálicas.

Las bujías de precalentamiento cerámicas se distinguen por las características siguientes:

- ✓ Tienen un tiempo de precalentamiento óptimo (máx. 3-4 segundos para llegar a 850 °C)
- ✓ Permiten alcanzar, sin deteriorarse, temperaturas más elevadas durante el postcalentamiento (más de 1200 °C, mientras que las bujías metálicas llegan al máximo a 1000-1125 °C)
- ✓ Pueden permanecer encendidas hasta 10 minutos después de la puesta en marcha (las bujías metálicas pueden resistir encendidas hasta un máximo de 3 minutos).
- ✓ Absorben menos potencia: menos de 40W en el postcalentamiento, mientras que las metálicas trabajan entre 70 y 80 W.

no elemento de aquecimento constituído por um material cerâmico especial a base de nitrato de silício que é equipado de uma resistência térmica, ao desgaste, a erosão e a oxidação superior aquela das ligas metálicas.

As performances das velas cerâmicas se distinguem porque:

- ✓ Têm um óptimo tempo de pré-aquecimento (3-4 seg. máx. para atingir 850°C);
- ✓ Permitem de atingir sem sofrer danos temperaturas mais altas durante o pós-aquecimento (mais de 1200 °C enquanto as velas metálicas podem chegar a 1000-1125°C máx.);
- ✓ Podem permanecer acesas até a 10 minutos depois da ignição (as velas metálicas podem resistir acesas até a 3 min. máx.);
- ✓ Absorvem menor potência: menos de 40W no pós-aquecimento enquanto as metálicas trabalham dentro os 70W e os 80 W.



## GR

Για την όλο και πληρέστερη κάλυψη των κυκλοφορούντων οχημάτων, η γκάμα προθερμαντήρων Magneti Marelli εμπλουτίστηκε με αναρίθμητους νέους κωδικούς μεταξύ των οποίων οι προθερμαντήρες νέας γενιάς με μύτη 4mm, οι κεραμικοί προθερμαντήρες και οι εντελώς νέοι προθερμαντήρες ultrafast μεταβαλλόμενης τάσης.

**Οι προθερμαντήρες CERAMIC**

Η νέα γενιά κινητήρων diesel, προκειμένου να ικανοποιήσει τους όλο και πιο αυστηρούς κανονισμούς σε θέματα ρύπανσης, κατέστησε αναγκαία τη χρήση προθερμαντήρων με υψηλότερες αποδόσεις οι οποίες εξασφαλίζονται από την κεραμική τεχνολογία.

Πράγματι, οι κεραμικοί προθερμαντήρες, χάρη στην ικανότητά τους να παραμένουν αναμμένοι για μεγαλύτερο διάστημα και να έχουν μεγαλύτερη αντοχή σε υψηλότερες θερμοκρασίες λειτουργίας, συμβάλλουν στη μείωση των βλαβερών εκπομπών και εξασφαλίζουν την τήρηση των πιο αυστηρών προδιαγραφών. Εξωτερικά, οι προθερμαντήρες με κεραμικό περίβλημα είναι παρόμοιοι με τους προθερμαντήρες με μεταλλικό περίβλημα. Η διαφορά έγκυται στο θερμαντικό στοιχείο το οποίο αποτελείται από ένα ειδικό υλικό με βάση το νιτρίδιο του πυριτίου το οποίο διαθέτει ανθεκτικότητα στη θερμότητα, στη φθορά, στη διάβρωση και στην οξειδωση μεγαλύτερη από τα μεταλλικά κράματα. Η αποδόσεις των κεραμικών προθερμαντήρων διακρίνονται γιατί:

- ✓ Έχουν ιδανικό χρόνο προθέρμανσης (3-4 δευτ. το πολύ για να φτάσουν στους 850°C)
- ✓ Επιτρέπουν την επίτευξη, χωρίς την πρόκληση βλάβης, υψηλότερων θερμοκρασιών κατά την προθέρμανση (πάνω από 1200° C ενώ οι μεταλλικοί προθερμαντήρες μπορούν να φτάσουν το πολύ έως 1000-1125°C)
- ✓ Μπορούν να παραμείνουν αναμμένοι έως και 10 λεπτά μετά την ανάφλεξη (οι μεταλλικοί προθερμαντήρες μπορούν να παραμείνουν αναμμένοι έως το πολύ 3 λεπτά).
- ✓ Απορροφούν μικρότερη ισχύ: λιγότερο από 40W κατά την προθέρμανση, ενώ οι μεταλλικοί λειτουργούν μεταξύ 70W και 80 W.

## PL

W celu zapewnienia jak najlepszego pokrycia rynku, gama świec Magneti Marelli wzbogaciła się o wiele nowych kodów, m.in. świece nowej generacji z końcówką 4mm, świece ceramiczne i nowe świece ultrafast o zmiennym napięciu.

**Świece CERAMIC**

W nowej generacji silników diesel, w celu spełnienia wymagań w zakresie ograniczenia zanieczyszczenia zawartych w coraz bardziej surowych przepisach, konieczne stało się użycie świec o wyższych osiągnięciach, które zostały stworzone dzięki technologii ceramicznej.

Świece ceramiczne, dzięki możliwości dłuższego świecenia i wytrzymałości na wyższą temperaturę funkcjonowania, pomagają w ograniczeniu szkodliwych emisji i gwarantują spełnienie najbardziej wymagających norm. Na zewnątrz ceramiczne świece zarówno są podobne do świec metalowych. Różnica tkwi w elemencie grzewczym, zbudowanym ze

## R

Для все более полного покрытия потребностей рынка фирма Magneti Marelli постоянно расширяет спектр производимых свечей накаливания; так, фирма начала выпуск свечей нового поколения с уменьшенным до 4-х мм диаметром оболочки нагревателя (штифта), керамических свечей, а так же новейших сверхбыстрых свечей накаливания, работающих на переменном напряжении (саморегулируемых).

**Свечи накаливания CERAMIC**

Дизельные двигатели нового поколения должны удовлетворять все более строгим нормам по защите окружающей среды, что породило спрос на свечи накаливания с улучшенными характеристиками. Такие характеристики обеспечиваются применением керамических материалов.

Действительно, керамические свечи накаливания вносят свой вклад в снижение вредных выбросов и позволяют двигателю удовлетворять самым строгим нормам по защите окружающей среды. Это достигается за счет их долговременного режима работы и более высокой рабочей температуры. По внешнему виду керамические свечи накаливания похожи на свечи с нагревателем в металлической оболочке; разница состоит в том, что нагревательный элемент у керамических свечей накаливания изготовлен из специального керамического материала на основе нитрида кремния. Этот материал обладает более высокими, по сравнению с металлическими сплавами, термической устойчивостью, износоустойчивостью, устойчивостью к эрозии и к окислению.

Керамические свечи накаливания обладают выдающимися характеристиками, а именно:

- ✓ Имеют превосходное быстродействие (максимум 3-4 сек до достижения температуры 850°C)
- ✓ Выдерживают без ущерба более высокие температуры в режиме прогрева двигателя (свыше 1200 °C, в то время как свечи накаливания с нагревателем в металлической оболочке могут достигать максимум 1000-1125 °C)
- ✓ Могут оставаться в рабочем режиме вплоть до 10 минут после запуска (свечи накаливания с нагревателем в металлической оболочке - максимум 3 минуты).
- ✓ Потребляют меньше энергии: потребляемая мощность керамических свечей в режиме прогрева двигателя составляет 40 Вт, а металлических – от 70 до 80 Вт.

specjalnego materiału ceramicznego na bazie azotku krzemu, który posiada wytrzymałość termiczną, odporność na zużycie, erozję i utlenianie wyższą od stopów metalowych.

Działanie świec ceramicznych wyróżnia się, ponieważ:

- ✓ Posiadają one optymalny czas podgrzewania (maks. 3-4 sekund w celu osiągnięcia temperatury 850°C)
- ✓ Umożliwiają osiągnięcie, bez doznania uszkodzeń, wyższych temperatur w okresie po grzaniu (ponad 1200° C, podczas, gdy świece metalowe mogą osiągnąć maksymalnie 1000-1125°C)
- ✓ Mogą pozostać zapalone aż do 10 minut po zaświeceniu (świece metalowe mogą pozostać zapalone przez maksymalnie 3 minuty).
- ✓ Pochłaniają mniej mocy: mniej niż 40W z fazy po grzaniu, podczas, gdy świece metalowe pochłaniają od 70W do 80W.

Piyasadaki bütün buji çeşitlerini kapsamak için Magneti Marelli, buji ürün çeşitlerine yeni jenerasyon modeller de eklemiştir; aralarına ucu 4mm'lik olanları, seramik olanları ve değişken voltajlı yepyeni ultrafast bujileri de dahil etmiştir.

#### CERAMIC kızdırma bujileri

Hava kirliliği konusunda uygulamada olan hep daha katı AB mevzuatına uyumlu bir biçimde üretilen yeni jenerasyon dizel motorları, seramik teknolojisinin garanti ettiği daha yüksek performanslı kızdırma bujilerinin kullanılmasını gerektirmektedir.

Nitekim, daha uzun bir süre yanık kalma özelliğine sahip ve daha yüksek bir çalışma ısısına dayanıklı olmaları sayesinde yeni seramik bujiler, sağlığa zararlı egzoz emisyonlarının azalmalarına katkıda bulunur ve en katı standartlara uyum şartlarını da sağlarlar. Görünüşte seramik kaplamalı kızdırma bujileri, metal kaplamalı olanlarına benzer; aralarındaki fark, diğer metal alaşımlarına göre ısıya, kullanıma, aşınımına ve oksidasyona çok daha dayanıklı olma özelliğini taşıyan sili-

kon nitrür bazlı özel bir seramik maddeden oluşan kızdırıcı unsurudur.

Seramik kızdırma bujilerinin performans özellikleri, aşağıdaki gibidir:

- ✓ optimal bir ön kızdırma süresine sahip olmaları (3-4 saniyede 850°C dereceye ulaşırlar),
- ✓ Kızdırma sonrası aşamasında hasar görmeden daha yüksek ısılara ulaşabilmeleri (öbür metal bujiler azami 1000-1125 dereceye ulaşabilirken, seramik kızdırma bujileri 1200 dereceyi aşan bir ısıya ulaşabilirler);
- ✓ Çalıştırdıktan 10 dk. sonrasına kadar kızgın durumda kalabilmeleri (metal bujiler maksimum 3 dk.'ya kadar kızgın durumda kalabilirler);
- ✓ Daha düşük bir güç çekmeleri (kızdırma sonrasında metal bujiler 70w-80w arası güç miktarı çekerlerken seramik kızdırma bujileri 40W'tan daha düşük bir güç çekerler.).

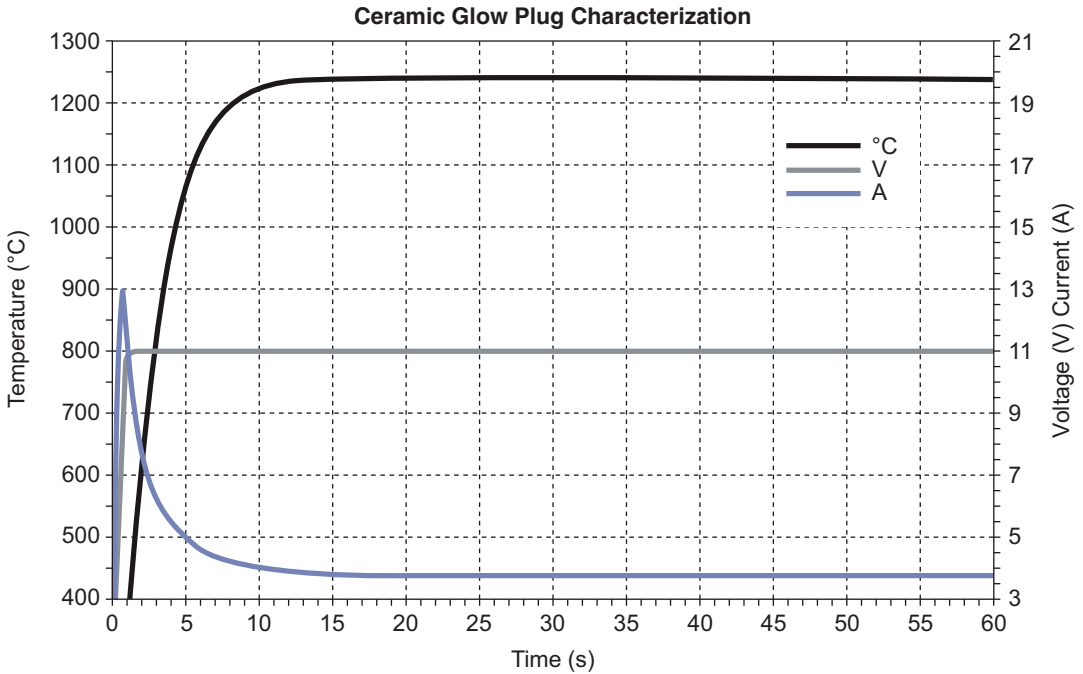

## I

**Le candele** *ULTRA FAST*

Sono candele metalliche con tensione di alimentazione variabile che, grazie a particolari caratteristiche costruttive e opportunamente pilotate dalla centralina di preriscaldamento, raggiungono la temperatura di funzionamento in meno di due secondi: l'avviamento del motore è dunque istantaneo anche in presenza delle più rigide condizioni ambientali.

Le candele *ULTRA FAST* sono progettate per operare in combinazione con un'unità elettronica di controllo che regola l'assorbimento di corrente. L'andamento della potenza assorbita e la conseguente variazione della temperatura è regolata sui valori richiesti dal motore in ogni specifico momento. Dopo la fase di preriscaldamento, in cui sono alimentate a 11 V, vengono alimentate con una tensione di 5V nel periodo di post-riscaldamento.

Le candele *ULTRA FAST* possono essere accese dall'unità di controllo anche dopo la fase di avviamento del motore, in qualsiasi momento le condizioni all'interno della camera di combustione lo richiedano. Il processo di combustione risulta così continuo e stabile e le emissioni nocive sono ridotte al minimo in quanto i suoi sottoprodotti vengono puntualmente bruciati.

## GB

*ULTRA FAST* glow plugs

Piloted by the preheat control unit, these are variable tension feed metal glow plugs that reach operational temperature in less than two seconds thanks to their particular design: hence engine ignition is immediate even in extreme environmental conditions.

*ULTRA FAST* glow plugs are designed to jointly operate with an electronic control unit that regulates current absorption. Quantity of absorbed current and consequent temperature variation is adjusted according to engine requirement at any specific moment. In the preheating phase the glow plugs receive 11V tension, then 5V in postheating period.

The *ULTRA FAST* glowplugs can be operated by the control unit even after engine ignition phase, i.e. any time conditions in the combustion chamber require them to be operational. In this way, the combustion process is continual and smoothening and harmful emissions are reduced to a minimum since combustion by-products are being burnt.

## D

**Die** *ULTRA FAST* **Glühkerzen**

Hierbei handelt es sich um Metallglühkerzen mit veränderlicher Spannungsversorgung, welche Dank derer besonderen konstruktiven Eigenschaften und durch geeignete Steuerung über das Vorglühssteuergerät, die Betriebstemperatur in weniger als 2 Sekunden erreichen: Das Anlassen des Motors erfolgt also sofort, selbst bei widrigsten Umweltbedingungen.

Die *ULTRA FAST* Glühkerzen sind dazu entworfen worden in Kombination mit einem elektronischen Steuergerät zu arbeiten, welche deren Stromaufnahme regelt. Der Verlauf der Leistungsaufnahme und die damit verbundene Änderung der Temperatur werden auf die in jedem spezifischen Moment vom Motor geforderten Werte geregelt. Nach der Phase des Vorglühsens, in der diese mit 11 V versorgt werden, erfolgt eine Versorgung mit einer Spannung von 5 V in der Zeit des Nachglühens.

Die *ULTRA FAST* Glühkerzen können vom Steuergerät auch jederzeit nach der Phase des Anlassens des Motors eingeschaltet werden, sofern die Bedingungen in der Brennkammer dies erforderlich machen. Der Verbrennungsprozess wird dadurch dauerhaft und stabil und der Ausstoß an umweltschädlichen Abgasen wird auf ein Minimum reduziert, da deren Unterprodukte dabei verbrannt werden.

## F

**Les bougies de préchauffage** *ULTRA FAST*

Il s'agit de bougies de préchauffage métalliques aux tensions d'alimentation variables qui, grâce à des caractéristiques de construction particulières et à un pilotage adapté par la centrale de préchauffage, atteignent les températures de fonctionnement en moins de deux secondes : le démarrage du moteur est donc instantané même dans les conditions de vie les plus difficiles.

Les bougies de préchauffage *ULTRA FAST* sont conçues pour fonctionner en combinaison avec une unité de contrôle électronique qui règle son absorption de courant. L'évolution de la puissance absorbée et la variation de la température qui en découle sont à chaque instant réglées par le moteur sur les valeurs demandées. Après la phase de préchauffage où elles sont alimentées à 11 V, une tension de 5 V leur est fournie lors de la période de post-chauffage.

Les bougies de préchauffage *ULTRA FAST* peuvent aussi être allumées par l'unité de contrôle après la phase de démarrage du moteur, à tout moment où les conditions à l'intérieur de la chambre de combustion le requièrent. Le processus de combustion est ainsi continu et stable, et les émissions nocives sont réduites au minimum puisque les sous-produits sont ponctuellement brûlés.

## E

Las bujías de precalentamiento *ULTRA FAST*

Son bujías metálicas con tensión de alimentación variable que, gracias a características de construcción particulares y mandadas por la centralita de precalefacción, alcanzan la temperatura de funcionamiento en menos de dos segundos; de tal forma el arranque del motor es inmediato, incluso en condiciones climáticas sumamente duras.

Las bujías *ULTRA FAST* están proyectadas para trabajar combinadas con una unidad electrónica de control, que regula la absorción de corriente. Dicha unidad regula la cantidad de potencia absorbida y la consiguiente variación de la temperatura según lo que requiera el motor en cada momento específico. Tras la fase de precalefacción, durante la cual reciben alimentación a 11 V, siguen siendo alimentadas a sólo 5 V en el período de postcalefacción.

La unidad de control puede encender las bujías de precalentamiento *ULTRA FAST* también después de la fase de arranque del motor, en cualquier momento en que lo requieran las condiciones en la cámara de combustión. De tal manera el proceso de combustión resulta continuo y estable, reduciéndose al mínimo las emisiones nocivas, cuyos subproductos se queman en cada instante.

## P

As velas *ULTRA FAST*

São velas metálicas com tensão de alimentação variável que, graças as particulares características de fabricação e adequadamente pilotadas pela unidade central de pré-aquecimento atingem a temperatura de funcionamento em menos de dois segundos: a ignição do motor é portanto, instantânea mesmo na presença das mais rígidas condições ambientais.

As velas *ULTRA FAST* foram projectadas para operar em combinação com uma unidade electrónica de controlo que regula o consumo de corrente. O andamento da potência absorvida e a consequente variação da temperatura é regulado nos valores pedidos pelo motor em qualquer específico momento. Depois da fase de pré-aquecimento, em cujo são alimentadas a 11 V, são alimentadas com uma tensão de 5V no período de pós-aquecimento.

As velas *ULTRA FAST* podem ser acesas pela unidade de controlo também depois da fase de arranque do motor, em qualquer momento as condições no interno da câmara de combustão o solicitem. O processo de combustão resulta deste modo contínuo e estável e as emissões nocivas são reduzidas ao mínimo pois os seus subprodutos são pontualmente queimados.

## GR

ΟΙ ΠΡΟΘΕΡΜΑΝΤΗΡΕΣ *ULTRA FAST*

Πρόκειται για μεταλλικούς προθερμαντήρες με μεταβλητή τάση τροφοδοσίας οι οποίοι, χάρη στα κατασκευαστικά τους χαρακτηριστικά και με την κατάλληλη καθοδήγηση από τον εγκέφαλο προθέρμανσης, φτάνουν στη θερμοκρασία λειτουργίας σε λιγότερο από δύο δευτερόλεπτα: η εκκίνηση του κινητήρα είναι συνεπώς στιγμιαία ακόμα και στις πιο επιβαρυνμένες περιβαλλοντικές συνθήκες.

Οι προθερμαντήρες *ULTRA FAST* έχουν σχεδιαστεί για να λειτουργούν σε συνδυασμό με μία ηλεκτρονική μονάδα ελέγχου που ρυθμίζει την απορρόφηση ρεύματος. Η εξέλιξη της απορροφούμενης ισχύος και η επακόλουθη μεταβολή της θερμοκρασίας ρυθμίζεται με βάση τις τιμές που απαιτούνται από τον κινητήρα σε κάθε συγκεκριμένη στιγμή. Μετά από τη φάση προθέρμανσης, κατά την οποία τροφοδοτούνται με 11 V, στο διάστημα μετά την προθέρμανση τροφοδοτούνται με τάση 5V.

Οι προθερμαντήρες *ULTRA FAST* μπορούν να ενεργοποιηθούν από τη μονάδα ελέγχου ακόμα και μετά τη φάση έναρξης λειτουργίας του κινητήρα, σε οποιαδήποτε στιγμή το απαιτήσουν οι συνθήκες στο εσωτερικό του θαλάμου καύσης. Η διαδικασία καύσης είναι με αυτόν τον τρόπο συνεχής και σταθερή και οι εκπομπές ρύπων μειώνονται στο ελάχιστο γιατί τα υποπροϊόντα της καίγονται.

## PL

Świece *ULTRA FAST*

Są to świece metalowe ze zmiennym napięciem zasilania, które, dzięki szczególnym cechom konstrukcyjnym i odpowiedniemu sterowaniu z jednostki kontrolnej grzania, osiągają temperaturę funkcjonowania w mniej niż dwie sekundy: uruchomienie silnika jest więc natychmiastowe, również w obecności najsurowszych warunków środowiska.

Świece *ULTRA FAST* zaprojektowane są w celu działania w połączeniu z elektroniczną jednostką kontrolną regulującą pochłanianie przez nie prądu. Zużycie mocy i wynikająca z niego zmiana temperatury ustawiane jest stale na wymaganych wartościach przez silnik. W fazie podgrzewania, wartość zasilania wynosi 11 V, w okresie po grzaniu napięcie wynosi 5V.

Świece *ULTRA FAST* mogą być uruchamiane przez jednostkę kontrolną również po fazie uruchomienia silnika, w jakikolwiek momencie, gdy wymagają tego warunki we wnętrzu komory spalania. W ten sposób proces spalania jest stały i stabilny i szkodliwe emisje ograniczone zostają do minimum, ponieważ ich produkty zostają spalane.

R

БЫСТРОДЕЙСТВУЮЩИЕ СВЕЧИ *ULTRA FAST*

Являются свечами накаливания с нагревателем в металлической оболочке, работающими на переменном напряжении (саморегулируемыми). Благодаря конструкционным особенностям и надлежащему управляющему воздействию блока управления, достигают рабочей температуры менее чем за 2 секунды, обеспечивая тем самым моментальный запуск двигателя даже в самых суровых климатических условиях.

Свечи накаливания *ULTRA FAST* разработаны для использования в сочетании с блоком управления, который регулирует потребляемый ими ток. Потребляемая мощность, а, следовательно, и температурный профиль, устанавливаются на значениях, требуемых для работы мотора в каждый момент времени. После фазы работы в режиме подогрева, когда свечи работают на напряжении 11 В, они переходят в режим прогрева двигателя и работают на напряжении 5 В.

Свечи накаливания *ULTRA FAST* могут включаться блоком управления двигателя так же в любой момент после окончания фазы прогрева двигателя, если того требуют условия в камере сгорания. Таким образом, обеспечивается непрерывность и стабильность процесса сгорания топлива, а значит, и выбросы в окружающую среду снижаются до минимума, поскольку побочные продукты горения дожигаются полностью.

TR

*ULTRA FAST* KIZDIRMA BUJİLERİ

Bunlar, değişken voltajlı metal kızdırma bujileridir; özel tasarım nitelikleri sayesinde ve ön kızdırma kontrol ünitesi tarafından uygun bir şekilde yönetildikleri için çalışma ısısına 2 saniyeden kısa bir sürede ulaşabilirler. Bu nedenle motor en sert hava şartlarında bile hemen çalışmaya başlar.

*ULTRA FAST* bujileri, akım çekimini ayarlayan bir kontrol ünitesi ile birlikte çalışacak şekilde tasarlanmışlardır. Çekilen elektrik gücünün miktarı ve buna bağlı olarak değişen ısı, her an motorun ihtiyacı olan değerlere ayarlanırlar. Ön kızdırma aşaması süresince 11 Volt, kızdırma sonrası aşamasında ise 5 Volt ile çalışırlar.

*ULTRA FAST* bujileri, motor çalıştırıldıktan sonra da, kontrol ünitesi tarafından yanma odası içindeki şartların gerektirdiği şekilde yakılabilirler. Yanma işlemi böylelikle devamlı ve düzenli olur ve yanma işleminde oluşan gazlar anında yakıldıkları için egzoz emisyonları asgariye inerler.

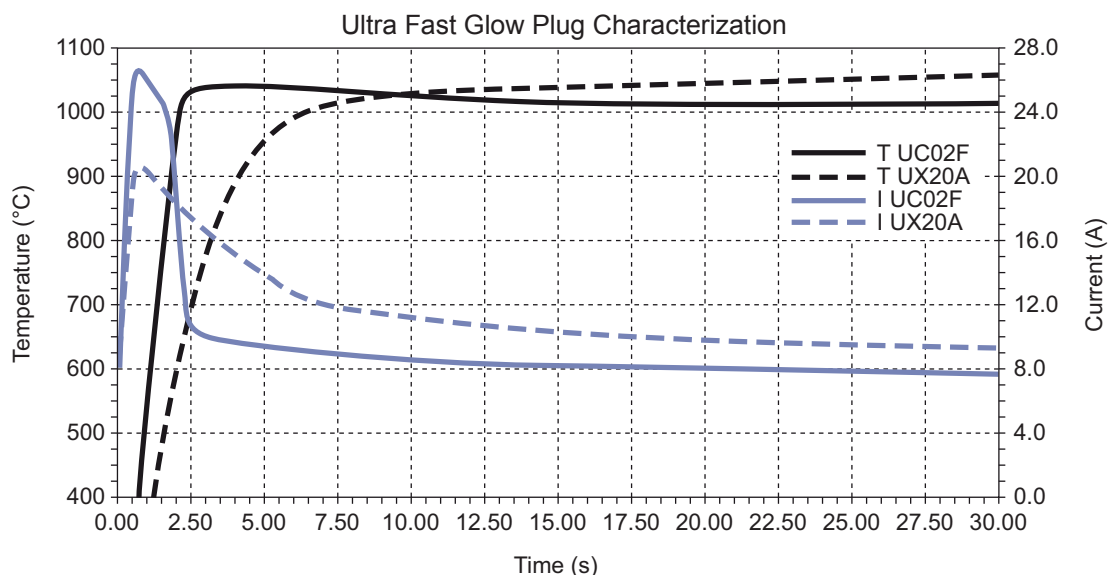

*Una sicurezza immediata*  
*Total reliability*  
*Sicherheit von Anfang an*  
*Une sécurité immédiate*  
*Una seguridad inmediata*

*Uma segurança imediata*  
*Άμεση ασφαλεία*  
*Natychmiastowe bezpieczeństwo*  
*Надежная работа, причем сразу*  
*Sağlam bir emniyet*

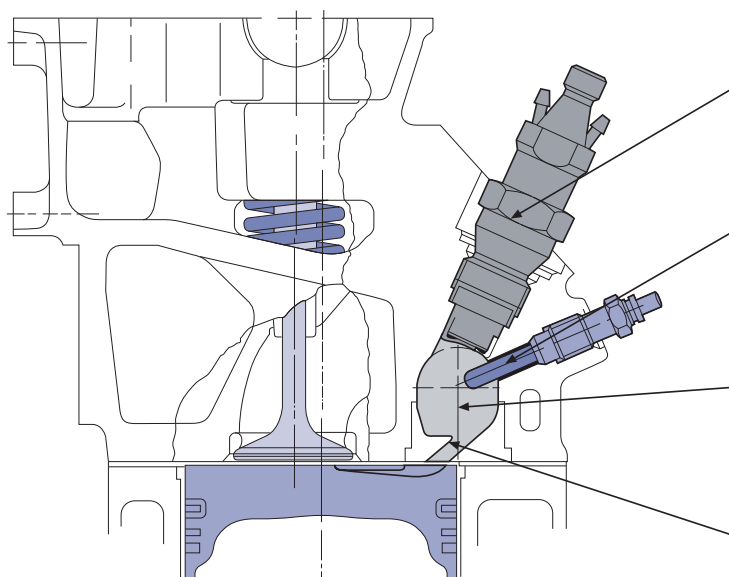

Inietore Injector Einspritzdüse Injecteur Inyector	Injector ΜΠεκ Wtryskiwacz Enjektör
Candeletta Glow plug Glühkerze Bougie Bujía	Velas Προθερμαντήρας Świeca Свеча Buji
Camera di turbolenza Swirl chamber Wirbelkammer Chambre de turbulence Câmara de turbulencia	Câmara de tubulência Θάλαμος περιδίνησης Komora wirkowa Вихревая камера Türbülans odası
Condotto Pipe Kanal Tubulure Conducto	Conduto Αγωγός Przewód Перепускной канал Akım taşıyıcı

Posizione di una candeletta a stilo nella camera di turbolenza  
 Position of a stylus glow plug in the swirl chamber  
 Anordnung einer Stabglühkerze in der Wirbelkammer  
 Position d'une bougie type stylo dans la chambre de turbulence  
 Posición de una bujía en la cámara de turbulencia  
 Posição de uma vela na câmara de turbulência  
 Θέση ενός προθερμαντήρα σε σχήμα ράβδου στο θάλαμο περιδίνησης  
 Pozycja trzpieniowej świecy żarowej w komorze wirkowej  
 Положение пальчиковой свечи накаливания в вихревой камере  
 Çubuk bujinin türbülans odasındaki pozisyonu

**I**

Parte integrante nel sistema del motore diesel, la candeletta di preriscaldamento Magneti Marelli è concepita per facilitare la fase di avviamento a freddo, elevando in modo rapido la temperatura della camera di combustione a 850 °C ed eliminando gli antichi tempi di attesa.

Svolge, inoltre, la fondamentale funzione di punto più caldo nel motore contribuendo in modo diretto al buon funzionamento dello stesso.

Realizzate con materiali specifici per resistere alle più impegnative sollecitazioni di tipo meccanico, tecnico, chimico ed elettrico, assicurano un alto rendimento e una lunga durata.

L'alta qualità di questi prodotti è assicurata dalla specifica esperienza di una grande Azienda europea, quale la Magneti Marelli, la quale, grazie alla costante collaborazione con i maggiori costruttori automobilistici, è in grado di proporre, puntualmente, prodotti perfettamente rispondenti alle esigenze di ogni motore.

**GB**

An integral part of the diesel engine system, the Magneti Marelli glow plug has been designed to facilitate the phase of cold-starting by quickly raising the temperature of the combustion chamber to 850 °C and eliminating the old waiting times.

In addition, it carries on the fundamental work of the hottest point in the engine directly contributing to the engine's good operation.

Made with specific materials to withstand the most demanding mechanical, technical, chemical and electrical stresses, they ensure high efficiency and a long service life.

The high quality of these products is ensured by the specific experience of a great European company, Magneti Marelli, which, thanks to constant cooperation with major motor car manufacturers, is able to punctually offer products in perfect compliance with the requirements of every engine.

**D**

Als Bestandteil des Dieselmotors ist die Magneti Marelli - Glühkerze so konzipiert, daß die Kaltstartphase erleichtert wird. Das heißt, die Temperatur in der Brennkammer wird schnell auf 850 °C gebracht, um so die lange Vor-glühzeit zu vermeiden.

Die Glühkerze ist der heibeste Punkt im Motor und muß trotz extremer Beanspruchung absolut zuverlässig funktionieren.

Um den Spitzenbelastungen mechanischer, technischer, chemischer und elektrischer Art stand zu halten, sind die Glühkerzen aus hochwertigen Materialien gefertigt, und garantieren somit einen hohen Wirkungsgrad und eine lange Lebensdauer.

Der hohe Qualitätsstandard wird durch die Erfahrung eines groben europäischen Unternehmens gesichert, nämlich Magneti Marelli, das Dank einer ständigen Zusammenarbeit mit den führenden Fahrzeugherstellern in der Lage ist, jederzeit Produkte anbieten zu können, die die Anforderungen der jeweiligen Motoren erfüllen

**F**

Partie intégrante du système du moteur diesel, la bougie de préchauffage Magneti Marelli est conçue pour faciliter la phase de démarrage à froid, élevant rapidement la température de la chambre de combustion à 850 °C et supprimant les anciens temps de chauffe.

La bougie de préchauffage remplit en outre le rôle fondamental de point le plus chaud du moteur, contribuant ainsi de façon directe à son bon fonctionnement.

Réalisée à l'aide de matériaux spécifiques afin de résister aux plus dures sollicitations mécaniques, techniques, chimiques et électriques, elle est gage de rendement élevé et d'une excellente longévité.

La haute qualité de ces produits est garantie par l'expérience spécifique d'une grande entreprise européenne comme Magneti Marelli, qui, grâce à une collaboration constante avec les plus importants constructeurs automobiles, est en mesure de proposer ponctuellement des produits répondant parfaitement aux exigences de chaque moteur.

**E**

Parte integrante del sistema del motor diesel, la bujía de precalentamiento Magneti Marelli ha sido concebida para facilitar la fase de arranque en frío, elevando rápidamente la temperatura de la cámara de combustión a 850 °C y eliminando los antiguos tiempos de espera.

Desarrolla, además, el ejercicio fundamental de punto más caliente en el motor contribuyendo directamente al buen funcionamiento del mismo.

Realizadas con materiales específicos para resistir incluso las necesidades de tipo mecánico, técnico, químico y eléctrico más duras, aseguran un alto rendimiento y una larga duración.

La alta calidad de estos productos está asegurada por la experiencia de una gran Empresa mundial, como Magneti Marelli, la cual gracias a la constante colaboración con los mayores constructores automovilísticos, está capacitada para proponer, puntualmente, productos perfectamente capaces de responder a las exigencias de cada motor.

**P**

Parte integrante do sistema do motor diesel, a vela de pré-aquecimento Magneti Marelli foi concebida para facilitar a fase de arranque em frio, aumentando rapidamente a temperatura da câmara de combustão a 850 °C e eliminando os tempos de espera.

Desenvolve, além disso o exercício fundamental do ponto mais quente no motor, contribuindo directamente para o bom funcionamento do mesmo.

Fabricadas com materiais específicos para resistir compreendendo as necessidades de tipo mecânico, técnico, químico e eléctrico mais duros, asseguram um alto rendimento e uma longa duração.

A alta qualidade destes produtos está assegurada pela experiência específica de uma grande empresa Europeia como a Magneti Marelli, a qual, graças à constante colaboração com os maiores construtores automobilísticos, está capacitada para propor, pontualmente, produtos perfeitamente capazes de responder às exigências de cada motor.

**GR**

Αναπόσπαστο τμήμα στο σύστημα του κινητήρα diesel, ο προθερμαντήρας Magneti Marelli έχει μελετηθεί προκειμένου να διευκολύνει την εκκίνηση με κρύο, ανεβάζοντας ταχύτητα τη θερμοκρασία στο θάλαμο καύσης στους 850 °C εκμηδενίζοντας τους χρόνους αναμονής του παρελθόντος.

Αποτελεί, επίσης, το πιο θερμό σημείο στον κινητήρα συμβάλλοντας έτσι άμεσα στην καλή λειτουργία του.

Κατασκευασμένοι από ειδικά υλικά προκειμένου να αντέχουν στις ισχυρές μηχανικές, τεχνικές, χημικές και ηλεκτρικές καταπονήσεις, εξασφαλίζουν υψηλή απόδοση και μεγάλη διάρκεια.

Η υψηλή ποιότητα αυτών των προϊόντων εξασφαλίζεται από την ειδική εμπειρία μιας μεγάλης ευρωπαϊκής Εταιρείας, όπως η Magneti Marelli, η οποία, χάρη στη σταθερή συνεργασία με τους μεγαλύτερους κατασκευαστές αυτοκινήτων, είναι σε θέση να προτείνει, συνεπής με το ραντεβού της στο χρόνο, προϊόντα που ανταποκρίνονται τέλεια στις ανάγκες κάθε κινητήρα.

**PL**

Integralna część silnika diesel, świeca żarowa Magneti Marelli, została opracowana w celu ułatwienia fazy rozruchu na zimno, podnosząc w szybki sposób temperaturę w komorze spalania do 850 °C i eliminując czas oczekiwania. Ponadto, świeca ta spełnia funkcję najcieplejszego punktu silnika, przyczyniając się w bezpośredni sposób do jego prawidłowego funkcjonowania.

Wykonana ze specjalnych materiałów odpornych na przeciążenia typu mechanicznego, technicznego, chemicznego i elektrycznego, zapewnia dużą wydajność i trwałość w czasie.

Wysoka jakość produktów gwarantowana jest dzięki doświadczeniu dużego zakładu europejskiego jakim jest spółka Magneti Marelli która, dzięki stałej współpracy z największymi producentami samochodów, jest w stanie punktualnie zaproponować produkty całkowicie zgodne z wymaganiami każdego silnika.

**R**

Свечи накаливания Magneti Marelli являются неотъемлемой частью дизельного двигателя. Они разработаны для облегчения запуска холодного двигателя за счет быстрого прогрева камеры сгорания до 850 °С, что позволяет обойтись без длительного времени ожидания, так распространенного в прошлом. Кроме того, они обеспечивают наличие горячей точки в моторе, внося тем самым прямой вклад в улучшение его работы.

Будучи изготовленными из специально подобранных материалов, обладают непревзойденной устойчивостью к механическим, техническим, химическим и электрическим воздействиям, обеспечивают высокую отдачу и долгий срок службы. Высочайшее качество продукции гарантируется огромным опытом работы в этой области такой фирмы европейского уровня, как Magneti Marelli. Фирма Magneti Marelli постоянно сотрудничает с ведущими европейскими производителями автомобилей, и поэтому способна предложить точно подобранную продукцию для любого мотора.

**TR**

Magneti Marelli'nin ön kızdırma bujileri, dizel motorlu sistemlere entegre edilmiş bir bileşen olarak yanma odasındaki ısıyı hızlı bir şekilde 850°C dereceye ulaştırıp eskiden olan bekleme süresini sıfırlayarak soğuk motorların çalıştırılmalarını kolaylaştırmak üzere tasarlanmışlardır.

Ayrıca, motorun en sıcak noktasında buldukları için en iyi şekilde çalışmasını sağlarlar.

Mekanik, teknik, kimyasal ve elektrik türlü en sert zorlanmalara dayanma amacıyla özel maddelerle yapılan bu bujiler, yüksek bir verimlilik ve uzun bir kullanım süresini sağlarlar.

Bu ürünlerin yüksek kalitesi, en büyük otomobil üretici firmaları ile süregelen işbirliği sayesinde her zaman her türlü motorun gereksinimlerini doğru bir şekilde karşılayabilecek çeşitli ürünler sunan Magneti Marelli gibi büyük bir Avrupa işletmesinin özel tecrübesi aracılığıyla sağlanmaktadır.



*Caratteristiche costruttive*  
*Features*  
*Konstruktive Eigenschaften*  
*Caractéristiques*  
*Características técnicas*

*Características técnicas*  
*Κατασκευαστικά χαρακτηριστικά*  
*Cechy konstrukcyjne*  
*Конструкционные характеристики*  
*Yapım özellikleri*

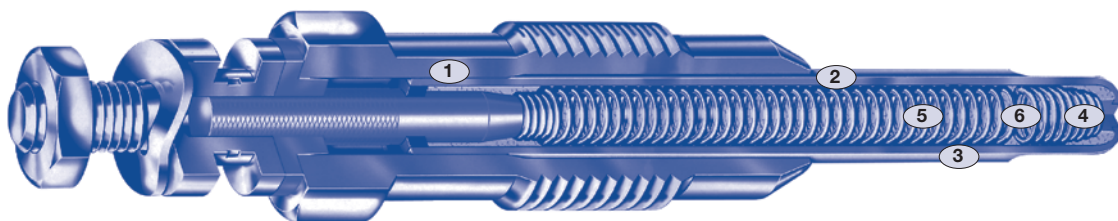

1

**Corpo con doppia sede di appoggio e speciale guarnizione isolante.**

Assicura una perfetta tenuta e isolamento.

**Body with twin seat and special insulating seal.**

Ensures a perfect seal and insulation.

**Körper mit doppeltem Dichtsitz und spezieller Isolierdichtung.**

Gewährleistet absolute Dichtheit und Isolierung.

**Corps à double zone d'appui et joint isolant spécial.**

Garantit une parfaite étanchéité et une excellente isolation.

**Cuerpo con doble base de apoyo y recubrimiento especial aislante.**

Asegura unas perfectas características de estanqueidad y aislamiento.

**Corpo com dupla sede de apoio e guarnição especial isolante.**

Assegura uma perfeita capacidade e isolamento.

**Σώμα με διπλή έδρα στήριξης και ειδική μονωτική τσιμούχα.**

Εξασφαλίζει τέλεια στεγανότητα και μόνωση.

**Korpus z podwójnym gniazdem i specjalną uszczelką izolacyjną.**

Zapewnia perfekcyjne przyleganie i izolację.

**Корпус с двойной опорной поверхностью и специальной изолирующей прокладкой.**

Обеспечивает безукоризненную непроницаемость и изоляцию.

**Çift dayamalı gövde ve özel yalıtkan lastik conta**  
Mükemmel bir tutturma ve izolasyon türünü sağlar.

2

**Guaina in superlega anticorrosione termica e chimica.**

Spessore variabile, specifico per ogni motore, in funzione delle temperature che si sviluppano all'interno delle precamere.

**Thermal and chemical corrosion-proof superalloy sheath.**

Variable thickness, specific for every engine, in relation to the temperatures developed in the precombustion chamber.

**Glührohr aus einer thermisch und chemisch resistenten Speziallegierung.**

Variable Stärke, je nach Motor, abhängig von den Temperaturen, die in der Vorkammer erreicht werden.

**Gaine en super-alliage anticorrosion thermique et chimique.**

Épaisseur variable, spécifique pour chaque moteur, en fonction des températures qui se développent à l'intérieur de la préchambre.

**Funda en superaleación anticorrosiva térmica y química.**

Espesor variable en función de la temperatura específica para cada motor, que se desarrolla en el interior de la precámara.

**Estojo em liga leve anti corrosão térmica e química.**

Espessura variável, específico para cada motor, em função das temperaturas que se desenvolvem no interior da precâmara.

**Περιβλήμα από υπερκράμα θερμικής και χημικής αντιδιάβρωσης.**

μεταβλητό πάχος, ειδικό για κάθε κινητήρα, σε συνάρτηση με τις θερμοκρασίες που αναπτύσσονται στο εσωτερικό των προθαλάμων.

**Powłoka ze stopu odpornego na korozję termiczną i chemiczną.**

Zmienna grubość w przypadku różnych silników, w zależności od temperatur, jakie występują we wnętrzu komór wstępnych

**Μεταλλική оболочка из антикоррозийного сплава (термо- и химически-стойкого).**

Различной толщины для разных двигателей, в зависимости от температуры, достигаемой в предкамере.

**Isil ve kimyasal aşınıma karşı yapılan süper alaşimli kaplama.**

Her motora göre spesifik olan kalınlığı, ön yanma odaları içinde oluşan ısılara göre değiştirilebilir.

3

**Polvere isolante (Mg 0) ad alta compressione.**

Il giusto compattamento elimina le intercapedini d'aria, evita di danneggiare il filamento resistivo isolandone le spire, conferendo alla candelella un'alta qualità.

**High compression insulating powder (Mg 0).**

The right compaction eliminates the air gaps and prevents damaging the resistive filament while insulating its turns, making the glow plug top grade.

**Hochkomprimierte Isolierfüllung aus Magnesiumoxid (Mg 0).**

Die völlige Abgeschlossenheit verhindert das Entstehen von Luftzwischenräumen.

Beschädigungen der Heizwendel werden durch die gegenseitige Isolierung der Windungen vermieden. Dies zeichnet eine Glühkerze von hoher Qualität aus.

**Poudres isolantes (Mg 0) à haute compression.**

Le juste compactage supprime les vides d'air, évite d'endommager le filament résistif en isolant les spires, conférant à la bougie une qualité supérieure.

**Polvo aislante (Mg 0) a alta compresión.**

El compactamento, que elimina las capas de aire que perjudican la duración del filamento y que aísla perfectamente la espiral, es de particular importancia para la calidad exigida a una bujía de precalentamiento.

**Pó izolante (Mg 0) de alta compressão.**

A justa densidade elimina os vazios de ar evitando de danificar o filamento resistente isolando as espirais, oferecendo às velas uma alta qualidade.

**Μονωτική σκόνη (Mg 0) υψηλής συμπίεσης.**

Η σωστή συμπεριφορά απομακρύνει τα ενδιάμεσα στρώματα αέρα, εμποδίζει την καταστροφή του επαγωγικού νήματος μονώνοντας τα σπειρώματα, αποδίδοντας έτσι απόλυτη ποιότητα.

**Proszek izolacyjny (Mg 0) o dużej kompresji.**

Odpowiednia kompaktacja eliminuje powstawanie przestrzeni powietrznych, zapobiega uszkodzeniu uzwojenia świecy, izolując jego zwoje i gwarantując wysoką jakość świecy.

**Диэлектрический порошок (MgO) высокого давления прессования.**

Правильно подобранное давление прессования позволяет избавиться от воздушной прослойки, изолирует витки спирали, не повреждая при этом нагревательного элемента, придает высочайшее качество свече накаливанию.

**Yüksek yoğunluklu izolasyon tozu (Mg 0)**

Uygun yoğunluk kıvamı hava boşluklarını yok eder, vidalama dışlarını koruyarak rezistans filamanının zarar görmesini engeller ve bujiye yüksek bir kalite sağlar.

4

**Filamento riscaldante.**

Riscalda rapidamente la miscela per ottenere accensioni rapide anche in condizioni estreme e mantiene alta la temperatura del motore dopo l'avviamento per emissioni più pulite.

**Heating coil.**

Heats rapidly for fast-starting in cold conditions and maintains high temperature after engine start-up for reduced emissions.

**Heizwendel.**

Erwärmt in kürzester Zeit das Gemisch, um ein schnelles Zünden auch unter extremen Bedingungen zu gewährleisten, wobei die Motortemperatur auch nach dem Anlassen des Motors auf einem hohen Niveau gehalten wird, um eine schadstoffärmere Emission zu erzielen.

**Filament chauffant.**

Il chauffe rapidement le mélange pour obtenir des allumages vites même en conditions extrêmes et il garde la température haute après le démarrage pour des émissions plus propres.

**Filamento calentador.**

Calienta rápidamente la mezcla para obtener un encendido rápido incluso en condiciones extremas y mantiene alta la temperatura del motor una vez en marcha obteniendo unas emisiones más limpias.

**Filamento de aquecimento.**

Aquece rapidamente a mistura para obter ignição rápida em condições extremas e mantém a temperatura do motor alta depois do arranque para emissões mais limpas.

**Νήμα θέρμανσης.**

Θερμαίνει ταχύτατα το μείγμα επιτυγχάνοντας άμεσες εκκινήσεις σε ακραίες συνθήκες και διατηρεί υψηλή τη θερμοκρασία του κινητήρα μετά την εκκίνηση για πιο καθαρές εκπομπές.

**Uzwojenie grzejne.**

Podgrzewa w szybki sposób mieszanę w celu natychmiastowego zapalenia również w ekstremalnych warunkach i utrzymuje wysoką temperaturę silnika po uruchomieniu, gwarantując czystsza emisję spalin.

**Нагревательная спираль.**

Быстро прогревает топливную смесь, что позволяет осуществлять быстрый запуск двигателя в экстремальных условиях, а так же поддерживает температуру в двигателе на должном уровне, способствуя снижению вредных выбросов в атмосферу.

**Kızdırıcı filaman**

Sert hava şartlarında bile motorun hızlı bir şekilde çalıştırılmasını sağlamak için yakıt-hava karışımını çabuk bir şekilde ısıtır, daha temiz egzoz emisyonlar elde etme doğrultusunda motor ısınısını yüksek derecede tutar.

5

**Filamento regolante.**

Grazie alle sue caratteristiche resistive controlla l'aumento della temperatura per riscaldare la miscela il più velocemente possibile e per permettere alla candelletta di restare calda fino a 3 minuti senza subire danni.

**Regulating coil.**

The resistance characteristics of this coil control the temperature rise to give fastest warm up while allowing it to remain heated up to three minutes without the risk of damage.

**Regelwendel.**

Dank der Widerstandscharakteristiken des Regelwendels wird der schnellstmögliche Temperaturanstieg zur Erwärmung des Gemisches gewährleistet. Darüber hinaus werden Schäden an der Kerze auch bei einer Nachglühzeit von 3 Minuten vermieden.

**Filament regulant.**

Grâce à ses caractéristiques résistives il contrôle l'augmentation de la température pour un préchauffage le plus vite possible et pour permettre à la bougie de rester chaude jusqu'à trois minutes sans risque de dommages.

**Filamento regulador.**

Gracias a sus características de resistencia controla el aumento de la temperatura para calentar la mezcla lo más rápido posible y así permitir que la bujía se mantenga caliente hasta 3 minutos sin riesgo de sufrir daños.

**Filamento regulador.**

Gracias às suas características resistentes controla o aumento da temperatura para aquecer a mistura o mais rapidamente possível e permite que as velas se mantenham aquecidas até 3 minutos sem causar danos.

**Νήμα ρύθμισης.**

Χάρη στα επαγωγικά χαρακτηριστικά του ελέγχει την αύξηση της θερμοκρασίας προκειμένου να θερμάνει το μείγμα όσο το δυνατόν πιο γρήγορα και να επιτρέψει στο θερμαντήρα να παραμείνει ζεστός έως και 3 λεπτά χωρίς να υποστεί βλάβη.

**Uzwojenie regulacyjne.**

Dzięki cechom rezystywnym kontroluje wzrost temperatury w celu jak najszybszego rozgrzania mieszanki i w celu umożliwienia świecy utrzymania wysokiej temperatury aż do 3 minut, bez powodowania jej uszkodzenia.

**Регулирующая спираль.**

Благодаря своим электрическим характеристикам регулирует повышение температуры для быстрого достижения рабочей температуры смеси, а так же для поддержания высокой температуры свечи в течение 3-х минут без ущерба для самой свечи.

**Ayarlanabilir filaman**

Dayanıklılık özellikleri sayesinde yakıt-hava karışımını en hızlı şekilde ısıtma ve bujinin 3 dakika boyunca kızgın kalmasını sağlama amacıyla ısı artışını gözetler.

6

**Saldatura dei filamenti a controllo costante di qualità.**  
Realizzate con processi interamente automatizzati, mediante fusione al laser.

**Filament welding with constant quality control.**

Made with entirely automated processes by means of laser fusion.

**Verschweiben der Heiz- und Regelwendel unter ständiger Qualitätskontrolle.**

Die gleichbleibend hohe Qualität wird mit einem komplett automatisierten Produktionsprozess erreicht. Bei dieser Herstellung kommt die Lasertechnik zum Einsatz.

**Soudure des filaments exécutée sous contrôle qualité constant.**

Les soudures sont réalisées selon des processus entièrement automatisés de fusion au laser.

**Soldadura del filamento, de calidad y control constante.**

Realizada con un proceso automatizado y mediante fusión al laser.

**Soldadura dos filamentos com controle constante de qualidade.**

Realizada com processos inteiramente automáticos mediante fecho ao laser.

**Συγκόλληση νημάτων με σταθερό έλεγχο ποιότητας.**

Κατασκευασμένα με απόλυτα αυτοματοποιημένες διαδικασίες, με τηξη μέσω laser.

**Spawanie uzwojenia i stała kontrola jakości.**

Wykonane przy użyciu procesów całkowicie zautomatyzowanych, za pomocą fuzji laserowej.

**Сварка нагревательных элементов, постоянный контроль качества.**

Осуществляется в полностью автоматизированном процессе посредством лазерной сварки.

**Sürekli kalite kontrollü filaman lehimlenmesi.**

Lazerli füzyon aracılığıyla tam otomatik süreçlerle gerçekleştirilir.

*Sistemazione di una candeletta su motore*

*Positioning of glow plug in engine*

*Einbaulage einer Glühkerze im Motor*

*Montage d'une bougie sur le moteur*

*Colocación de una bujía en el motor*

*Colocação de uma vela no motor*  
*Τακτοποίηση ενός προθερμαντήρα στον κινητήρα*

*Umieszczenie świecy w silniku*

*Установка свечи накаливания в двигатель*

*Bujinin motor üzerine yerleştirilmesi*

Iniettore  
Injector  
Einspritzdüse  
Injecteur  
Inyector

Injector  
Μπτεκ  
Wtrysk  
Инжектор  
Enjektör

Precamera  
Precombustion chamber  
Vorkammer  
Préchambre  
Precamara

Pre-Camara  
Προθάλαμος  
Komora wstępna  
Предкамера  
Ön yanma odası

Angolo di spruzzo  
Spray angle  
Einspritzwinkel  
Angle d'injection  
Cono de pulverización  
Angulo burrifo  
Γωνία ψεκασμού  
Kąt rozpylenia  
Угол впрыска  
Püskürtme açısı

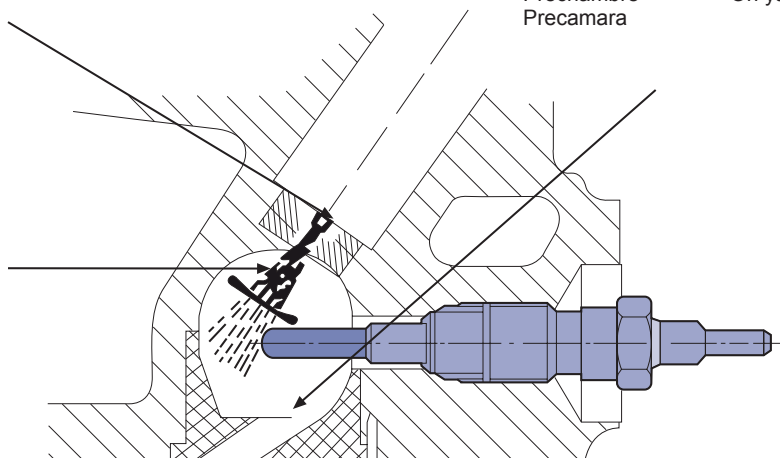

**I**

La posizione della punta incandescente può trovarsi compresa tra la periferia e il centro della precamera a seconda del tipo di motore e del tipo di richiesta di prestazioni tecniche.

Nel caso di candele a filamento, questo deve sfiorare il cono di spruzzo.

**D**

Die Position der Kraftstoffentzündung kann sich im Zentrum der Vorkammer oder mehr am Rand der Vorkammer befinden. Dies hängt vom Motortyp und von den geforderten technischen Leistungen ab.

Im Fall der Stabglühkerze muß den Entzündungspunkt der Einspritzkegel berühren.

**GB**

The position of the incandescent tip may be between the edge and the centre of the precombustion chamber depending on the type of engine and the type of technical performance required.

In the case of filament glow plugs, the filament must skim the spray cone.

**F**

Selon le type de moteur et le type performances techniques désirées, la pointe incandescente peut être positionnée entre le pourtour et le centre de la préchambre.

Dans le cas des bougies à filament, ce dernier doit effleurer le cône d'injection

**E**

La posición de la punta incandescente puede estar comprendida entre la periferia y el centro de la precámara según el tipo de motor y el tipo de prestaciones técnicas que se le pidan.

En el caso de bujías de filamento, éste debe rozar el cono de pulverización.

**P**

A posição de uma ponta incandescente pode estar compreendida entre a periferia e o centro da précamara segundo o tipo de motor e o tipo de prestações técnicas que lhe peçam.

No caso das velas de filamento, esta deve proteger o cone de pulverização.

**GR**

Η θέση της πυρακτωμένης μύτης μπορεί να βρίσκεται ανάμεσα στην περιφέρεια και το κέντρο του προθαλάμου ανάλογα με τον τύπο του κινητήρα και το είδος των τεχνικών απαιτήσεων απόδοσης.

Στην περίπτωση προθερμαντήρων με νήμα, πρέπει σχεδόν να αγγίζει τον κώνο ψεκασμού.

**PL**

Żarowa końcówka może być umieszczona między częścią boczną i środkiem komory wstępnej, w zależności od rodzaju silnika i wymagań osiągnięć technicznych.

W przypadku świec z uzwojeniem, uzwojenie powinno lekko dotykać kąta rozpylenia.

**R**

Положение нагревательного элемента (штифта) зависит как от типа мотора, так и от искомых параметров работы, и может быть смещено ближе к центру или же ближе к периферической области предкамеры.

В случае свечей с нагревательной спиралью, эта спираль должна касаться конуса впрыска.

**TR**

Bujinin kızgın ucu, motor türüne ve elde edilmesi istenilen teknik performanslara göre ön yanma odasının dış bölümü ile orta bölümü arasında yerleştirilebilir. Filamanlı buji kullanıldığında filaman, püskürtme konisine hafifçe değmelidir.

*Consigli per la sostituzione*

*Fitting hints*

*Hinweise zum Wechseln der Glükerzen*

*Conseils pour la substitution*

*Consejos para la substitución*

*Conselhos para a substituição*

*Συμβουλές για την αντικατάσταση*

*Zalecenia podczas wymiany*

*Советы по замене свечей*

*Buji deđişimi hakkında öneriler*

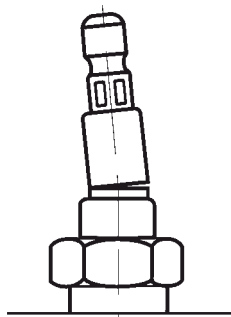

Fig. 1

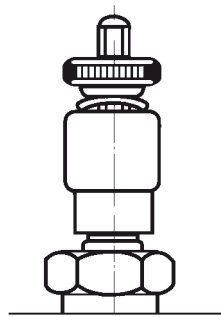

Fig. 2

**I**

Nel collegamento delle candele, comunque realizzato mediante morsetti, piattine, cavi, ecc., il terminale non deve essere sollecitato con eccessive flessioni, causa di possibili deformazioni (Fig. 1) e guasti alla tenuta della guarnizione. In queste condizioni e a causa di alternanze termiche (riscaldamento all'avviamento e raffreddamento all'arresto del motore), potrebbero venire aspirati all'interno della resistenza corazzata vapori di nafta, umidità, olio, ecc., con pericolo di corto circuito o interruzione della resistenza.

Nei collegamenti di candele con terminale filettato e morsetto godronato (Fig. 2), occorre eseguire il serraggio manualmente senza l'ausilio di pinze.

**D**

Beim Einschrauben und Anschließen der neuen Glühkerzen, muß mit grober Aufmerksamkeit vorgegangen werden. Es darf keine Gewalt angewendet werden. Wird der Anschlußbolzen zu stark hin- und herbewegt, kann die Dichtung beschädigt werden. Feuchtigkeit, Kraftstoffnebel, Öl etc. können eindringen.

Die Folge wäre ein Kurzschluss oder eine Widerstandunterbrechung.

Um eine einwandfreie Funktionalität zu gewährleisten, sollten die Kerzen mit der Hand, ohne Gebrauch von Werkzeugen, angezogen werden.

**GB**

When connecting glow plugs, no matter how this is done with clamps, straps, cables, etc., the terminal must not be bent too much, which is the cause of possible deformation (Fig. 1) and trouble with the seal. In these conditions and because of thermal alternation (heating on starting up and cooling on stopping the engine), diesel vapours, moisture, oil, etc. could get drawn inside the armoured resistor with the risk of short-circuiting or cut-off.

When connecting glow plugs with a threaded terminal and knurled clamp (Fig. 2), it is necessary to tighten by hand without the aid of pliers.

**F**

Lors du branchement des bougies, toujours réalisé à l'aide de bornes, bandes, câbles etc., la tige de connexion ne doit pas subir de flexions excessives pouvant causer des déformations (Fig. 1) et compromettre l'étanchéité du joint. En effet, les variations thermiques (réchauffage au démarrage et refroidissement à l'arrêt du moteur) pourraient entraîner l'aspiration de vapeurs de gas-oil, humidité, huile etc., à l'intérieur de la résistance blindée et provoquer des courts-circuits ou une interruption de la résistance. Lors du branchement de bougies avec une tige de connexion filettée et un écrou moleté (Fig. 2) il faut effectuer le serrage manuellement, sans l'aide de pinces.

**E**

Para la conexión de las bujías, realizada mediante bornes, platillos, cables, etc., no hay que presionar el terminal con excesivas flexiones, ya que podría ser causa de posibles deformaciones (Fig. 1) y averías en el asiento de la garnición. En estas condiciones y debido a alternancias térmicas (recalentamiento en el arranque y enfriamiento en la detención del motor), la resistencia acorazada podría absorber vapores de fuel, humedad, aceite, etc., con peligro de corto circuito o de interrupción de la resistencia. En las conexiones de bujías con terminal de rosca y borne grondante (Fig. 2), hay que realizar el ajuste manualmente sin la ayuda de herramientas.

**P**

Para a conexão das velas, realizada mediante os bornes, pratos, cabos, etc., não deve pressionar o terminal com excessivas flexões, já que poderiam ser a causa de possíveis deformações (Fig. 1) e avarias no assento da junta. Nestas condições e devido às alternâncias térmicas (reaquecimento no arranque e arrefecimento na detenção do motor), a resistência couraçada poderia absorver vapores de combustível, humidade, óleo, etc., com perigo de curto circuito ou de interrupção da resistência. Nas conexões de velas com terminal de rosca e borne gordurento (Fig. 2), tem que se efectuar um ajuste manualmente sem a ajuda de ferramentas.

**GR**

Στη σύνδεση των προθερμαντήρων, που σε κάθε περίπτωση υλοποιείται με σφιγκτήρες, ταινίες σύσφιξης, καλώδια, κλπ., ο ακροδέκτης δεν πρέπει να πιέζεται με υπερβολικές κάμψεις, που είναι η αιτία για πιθανές παραμορφώσεις (Εικ. 1) και βλάβες στη στεγανότητα των τσιμουχών. Υπό αυτές τις συνθήκες και εξαιτίας των θερμικών εναλλαγών (θέρμανση κατά την εκκίνηση και ψύξη κατά την παύση λειτουργίας του κινητήρα), ενδέχεται να απορροφηθούν στο εσωτερικό της θωρακισμένης αντίστασης ατμοί πετρελαίου, υγρασία, λάδι, κλπ., με κίνδυνο βραχυκυκλώματος ή διακοπής της αντίστασης.

Στις συνδέσεις των προθερμαντήρων με ακροδέκτη με νήμα και σφιγκτήρα ζαγρέ (Εικ. 2), η σύσφιξη πρέπει να γίνει με το χέρι χωρίς πένσα.

**PL**

Podczas łączenia świec, wykonywanego zawsze za pomocą zacisków, taśm, kabli, itp., końcówka nie powinna być narażona na nadmierne zagięcia, ponieważ może to spowodować deformacje (Rys. 1) i uszkodzenia szczelności uszczelek. W takich warunkach i na skutek zmian termicznych (rozgrzanie podczas uruchamiania i ochłodzenie podczas zatrzymania silnika) mogłyby zostać zassane do wnętrza opary nafty, wilgoć, olej, itp., powodując niebezpieczeństwo powstania zwarcia lub odłączenia.

Podczas łączenia świec z gwintowaną końcówką i zaciskiem radełkowym (Fig. 2), należy dokręcić świecę manualnie, bez użycia szczypców.

**R**

При подключении свечей накаливания, независимо от используемого типа электрического соединения (зажимы, клипсы, провода и т. д.), не следует механически нагружать клемму, во избежание ее деформации (см. рис. 1) и нарушения герметичности уплотнительной прокладки. Работая при переменной температуре (высокая при запуске двигателя и низкая при его остановке), свеча с нарушенным уплотнением может подсосывать внутрь пары топлива, масла, влагу и т. д., что может привести к короткому замыканию или обрыву нагревательной спирали.

В случае использования свечей с резьбовой клеммой и гайки с накаткой (см. рис. 2), закручивание следует производить от руки, без использования ключей.

**TR**

Bujiler, mengene, düz ikili kablo veya normal kablo kullanılarak monte edildiklerinde bağlantı civatalarına güçlü bir baskı uygulanmamalıdır, aksi takdirde deformasyonlar (Resim 1) ve lastik contanın tutturma bozukluğu ortaya çıkabilir. Bu şartlarda ve ısı değişimlerinden dolayı (motor çalıştırılmasındaki ısınma ve kapatılmasındaki soğuma) mazot buharları, nem, yağ vb. korumalı rezistans içine sızıp kısa devre olmasına veya rezistansın kopmasına neden olabilir.

Bağlantı civatalı bujilerin el mengenesine bağlandıklarında somun (Resim 2), pens kullanılmaksızın elle sıkılmalıdır.





*Applicazione per marca e veicolo*  
*Vehicle application guide*  
*Zuordnung nach Marke und Fahrzeug*  
*Affectations par marques et véhicules*  
*Aplicación por marca y vehículo*  
*Aplicação por marca e veículo*  
*Εφαρμογή ανα μοντελο*  
*Zastosowanie dla marki i pojazdu*  
*Применение*  
*Marka ve otomobile göre uygulama*

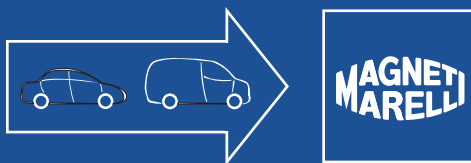

**kW**
**cc**
**V**

**MAGNETI MARELLI**
**ALFA ROMEO**
**145**

1.9 TD	4	66	1929	11	AR 33601, AR 67501	10/94→02/99	<b>UX20A</b>
1.9 JTD	4	77	1910	11	AR 32302	02/99→10/99	<b>UC11A</b>
1.9 JTD	4	77	1910	11	AR 32302	11/99→01/01	<b>UC19A</b>

**146**

1.9 TD	4	66	1929	11	AR 33601, AR 67501	12/94→02/99	<b>UX20A</b>
1.9 JTD	4	77	1910	11	AR 32302	02/99→10/99	<b>UC11A</b>
1.9 JTD	4	77	1910	11	AR 32302	11/99→01/01	<b>UC19A</b>

**147**

1.9 JTD	4	74	1910	11	182 B9.000	06/03→	<b>UC19A</b>
1.9 JTD	4	85	1910	11	937 A2.000	04/01→	<b>UC19A</b>
1.9 JTDM 8V	4	88	1910	11	937 A3.000	07/05→	<b>UC43A</b>
1.9 JTD 16V	4	103	1910	11	192 A5.000	11/02→	<b>UY3A</b>
1.9 JTDM 16V	4	110	1910	11	937 A5.000	07/05→	<b>UY3A</b>

**155**

1.9 TD	4	66	1929	11	AR 67501	04/93→12/97	<b>UX20A</b>
2.5 TD	4	92	2499	11	VM 07 B, VM 31 B	04/93→04/95	<b>UX20A</b>
2.5 TD	4	92	2499	11	VM 07 B, VM 31 B	05/95→12/97	<b>UC14A</b>

**156**

1.9 JTD	4	77	1910	11	AR 32302	09/97→10/00	<b>UC11A</b>
1.9 JTD	4	81	1910	11	AR 37101	10/00→05/01	<b>UC19A</b>
1.9 JTD	4	85	1910	11	937 A2.000	05/01→09/05	<b>UC19A</b>
1.9 JTD 16V	4	103	1910	11	192 A5.000	11/02→09/05	<b>UY3A</b>
2.4 JTD	5	100	2387	11	AR 32501	09/97→11/99	<b>UC11A</b>
2.4 JTD	5	100	2387	11	AR 32501	11/99→10/00	<b>UC19A</b>
2.4 JTD	5	103	2387	11	839 A6.000	10/00→09/05	<b>UC19A</b>
2.4 JTD	5	110	2387	11	841 C000	03/02→09/05	<b>UC19A</b>
2.4 JTD	5	129	2387	11	841 G.000	10/03→09/05	<b>UC19A</b>

**156 Sportwagon**

1.9 JTD	4	77	1910	11	AR 32302	05/00→10/00	<b>UC11A</b>
1.9 JTD	4	81	1910	11	AR 37101	10/00→05/01	<b>UC19A</b>
1.9 JTD	4	85	1910	11	937 A2.000	05/01→05/06	<b>UC19A</b>
1.9 JTD 16V	4	103	1910	11	192 A5.000	11/02→05/06	<b>UY3A</b>
1.9 JTD 16V Q4	4	110	1910	11	937 A5.000	07/04→05/06	<b>UY3A</b>
2.4 JTD	5	100	2387	11	AR 32501	05/00→10/00	<b>UC19A</b>
2.4 JTD	5	103	2387	11	839 A6.000	10/00→05/06	<b>UC19A</b>
2.4 JTD	5	110	2387	11	841 C000	03/02→05/06	<b>UC19A</b>
2.4 JTD	5	129	2387	11	841 G.000	10/03→05/06	<b>UC19A</b>



kW

cc

V

MAGNETI  
MARELLI**ALFA ROMEO****159**

1.9 JTDM 8V	4	88	1910	11	939A1.000	09/05→	<b>UC19A</b>
1.9 JTDM 16V	4	110	1910	11	939A2.000	09/05→	<b>UY3A</b>
2.4 JTDM	5	147	2387	11	939A3.000	09/05→	<b>UY3A</b>

**164**

2.5 TD	4	84	2500	11	VM 84 A	06/87→09/92	<b>UX7A</b>
2.5 TD	4	92	2499	11	VM 08 B, VM 32 B	09/92→04/95	<b>UX20A</b>
2.5 TD	4	92	2499	11	VM 08 B, VM 32 B	05/95→09/98	<b>UC14A</b>

**166**

2.4 JTD	5	100	2387	11	AR 34202	09/98→10/00	<b>UC11A</b>
2.4 JTD	5	103	2387	11	839 A6.000	10/00→	<b>UC19A</b>
2.4 JTD	5	110	2387	11	841 C000	04/02→	<b>UC19A</b>
2.4 JTD	5	129	2387	11	841 G.000, 841 H.000	10/03→	<b>UY3A</b>

**GT**

1.9 JTD	4	110	1910	11	937 A5.000	11/03→	<b>UY3A</b>
---------	---	-----	------	----	------------	--------	-------------

**AUDI****80**

1.9 TD	4	55	1896	11	AAZ	09/91→12/94	<b>UX25A</b>
1.9 TDI	4	66	1896	11	1Z	09/91→12/94	<b>UC31A</b>

**80 Avant**

1.9 TD	4	55	1896	11	AAZ	09/91→12/94	<b>UX25A</b>
1.9 TDI	4	66	1896	11	1Z	07/92→01/96	<b>UC31A</b>

**100**

2.5 TDI	5	88	2461	11	1T	01/90→11/90	<b>UC31A</b>
2.4 D 10V	5	60	2370	11	AAS	12/90→06/94	<b>UX8A</b>
2.4 D	5	60	2370	11	AAS	12/90→06/94	<b>UX25A</b>
2.5 TDI	5	85	2461	11	AAT, ABP	12/90→06/94	<b>UC31A</b>

**100 Avant**

2.4 D	5	60	2370	11	AAS	12/90→06/94	<b>UX25A</b>
2.5 TDI	5	85	2461	11	AAT, ABP	12/90→06/94	<b>UC31A</b>

**A2**

1.2 TDI	3	45	1191	11	ANY	03/01→08/05	<b>UC14A</b>
1.4 TDI	3	55	1422	11	AMF, BHC	02/00→08/03	<b>UC14A</b>
1.4 TDI	3	55	1422	5	AMF, BHC	09/03→	<b>UC01F</b>
1.4 TDI	3	66	1422	5	ATL	11/03→08/05	<b>UC01F</b>

**A3**

1.9 TDI	4	66	1896	11	AGR, ALH	09/96→07/01	<b>UC31A</b>
1.9 TDI	4	74	1896	11	ATD, AXR	10/00→	<b>UC31A</b>



### AUDI

1.9 TDI	4	77	1896	5	BKC	05/03→	UC01F
1.9 TDI	4	81	1896	11	AHF, ASV	08/97→07/01	UC31A
1.9 TDI	4	96	1896	11	ASZ	08/00→05/03	UC31A
1.9 TDI	4	96	1896	11	ASZ	06/03→	UC14A
1.9 TDI quattro	4	96	1896	11	ASZ	08/00→05/03	UC31A
1.9 TDI quattro	4	96	1896	11	ASZ	06/03→	UC14A
2.0 TDI	4	100	1968	4,4	AZV	05/03→	UC03F
2.0 TDI quattro	4	100	1968	4,4	AZV	05/03→	UC03F
2.0 TDI 16V	4	103	1968	4,4	BKD, BMM	05/03→	UC03F
2.0 TDI 16V quattro	4	103	1968	4,4	BKD, BMM	08/04→	UC03F

### A3 Sportback

1.9 TDI	4	77	1896	5	BKC	09/04→	UC01F
2.0 TDI	4	100	1968	4,4	AZV	09/04→	UC03F
2.0 TDI 16V	4	103	1968	4,4	BKD, BMM	09/04→	UC03F
2.0 TDI 16V quattro	4	103	1968	4,4	BMM	11/05→	UC03F

### A4

1.9 TDI	4	55	1896	11	AFF	12/95→11/00	UC31A
1.9 TDI	4	66	1896	11	1Z, AHH, AHU	01/95→11/00	UC31A
1.9 TDI	4	74	1896	11	AVB	05/01→12/04	UC31A
1.9 TDI	4	81	1896	11	AFN, AVG	10/95→11/00	UC31A
1.9 TDI quattro	4	81	1896	11	AFN, AVG	09/96→11/00	UC31A
1.9 TDI	4	85	1896	11	AJM	03/00→11/00	UC31A
1.9 TDI quattro	4	85	1896	11	AJM, ATJ	03/00→11/00	UC31A
1.9 TDI	4	85	1896	5	BKE	06/04→12/04	UC01F
1.9 TDI	4	85	1896	5	BKE, BRB	11/04→	UC01F
1.9 TDI	4	96	1896	11	AVF, AWX	11/00→12/04	UC31A
1.9 TDI quattro	4	96	1896	11	AVF	11/01→12/04	UC31A
2.0 TDI	4	100	1968	4,4	BNA	11/04→	UC03F
2.0 TDI 16V	4	103	1968	4,4	BLB, BPW	11/04→	UC03F
2.5 TDI	6	110	2496	11	AFB, AKN	09/97→11/00	UC45A
2.5 TDI	6	114	2496	11	AYM	08/01→07/02	UC45A
2.5 TDI	6	120	2496	11	BCZ, BDG, BFC	07/02→12/04	UC45A
2.5 TDI	6	120	2496	11	BCZ, BDG	11/04→	UC45A
2.5 TDI quattro	6	132	2496	11	AFB, AKN	09/97→11/00	UC45A
2.5 TDI quattro	6	132	2496	11	AKE, BAU, BDH	11/00→12/04	UC45A
2.7 TDI	6	132	2698	4,4	BPP	01/06→	UY7A
3.0 TDI quattro	6	150	2967	4,4	BKN	11/04→	UY7A
3.0 TDI quattro	6	171	2967	4,4	ASB	01/06→	UY7A



## AUDI

### A4 Avant

1.9 TDI	4	55	1896	11	AFF	03/96→09/01	UC31A
1.9 TDI	4	66	1896	11	1Z, AHH, AHU	02/96→09/01	UC31A
1.9 TDI	4	74	1896	11	AVB	11/01→12/04	UC31A
1.9 TDI	4	81	1896	11	AFN, AVG	02/96→09/01	UC31A
1.9 TDI quattro	4	81	1896	11	AFN, AVG	09/96→09/01	UC31A
1.9 TDI	4	85	1896	11	AJM	03/00→09/01	UC31A
1.9 TDI quattro	4	85	1896	11	AJM, ATJ	03/00→09/01	UC31A
1.9 TDI	4	85	1896	5	BKE	06/04→12/04	UC01F
1.9 TDI	4	85	1896	5	BKE, BRB	11/04→	UC01F
1.9 TDI	4	96	1896	11	AVF, AWX	09/01→12/04	UC31A
1.9 TDI quattro	4	96	1896	11	AVF	11/01→12/04	UC31A
2.0 TDI 16V	4	103	1968	4,4	BLB, BRE	11/04→	UC03F
2.5 TDI	6	110	2496	11	AFB, AKN	09/97→09/01	UC45A
2.5 TDI quattro	6	110	2496	11	AFB, AKN	09/97→09/01	UC45A
2.5 TDI	6	114	2496	11	AYM	09/01→07/02	UC45A
2.5 TDI	6	120	2496	11	BCZ, BDG, BFC	07/02→12/04	UC45A
2.5 TDI	6	120	2496	11	BDG	11/04→05/06	UC45A
2.5 TDI quattro	6	132	2496	11	AKE, BAU, BDH	09/01→12/04	UC45A
2.7 TDI	6	132	2698	4,4	BPP	01/06→	UY7A
3.0 TDI quattro	6	150	2967	4,4	BKN	11/04→	UY7A
3.0 TDI quattro	6	171	2967	4,4	ASB	01/06→	UY7A

### A4 Convertible

2.0 TDI	4	103	1968	5	BPW	01/06→	UC02F
2.5 TDI	6	120	2496	11	BCZ, BDG, BFC	08/02→12/05	UC45A
2.7 TDI	6	132	2698	4,4	BPP	06/06→	UY7A
3.0 TDI quattro	6	171	2967	4,4	ASB	10/05→	UY7A

### A5

2.7 TDI	6	140	2698	4,4		06/07→	UY7A
3.0 TDI quattro	6	174	2967	4,4		06/07→	UY7A

### A6

1.9 TDI	4	66	1896	11	1Z, AHU	06/94→10/97	UC31A
1.9 TDI	4	81	1896	11	AFN, AVG	04/97→10/00	UC31A
1.9 TDI	4	85	1896	11	AJM	07/00→01/05	UC31A
1.9 TDI	4	96	1896	11	AVF, AWX	08/01→01/05	UC31A
2.0 TDI	4	100	1968	4,4	BNA, BRF	06/05→	UC03F
2.0 TDI	4	103	1968	4,4	BLB, BRE	07/04→	UC03F
2.5 TDI	6	84	2496	11	AAT	01/95→10/97	UC31A
2.5 TDI	6	85	2496	11	AAT	06/94→10/97	UC31A



### AUDI

2.5 TDI	6	103	2496	11	AEL	08/94→02/97	UC31A
2.5 TDI quattro	6	103	2496	11	AEL	10/95→10/97	UC31A
2.5 TDI	6	110	2496	11	AFB, AKN	07/97→01/05	UC45A
2.5 TDI quattro	6	110	2496	11	AFB, AKN	07/97→01/05	UC45A
2.5 TDI	6	114	2496	11	AYM	08/01→01/05	UC45A
2.5 TDI	6	120	2496	11	BCZ, BDG, BFC	07/02→01/05	UC45A
2.5 TDI	6	132	2496	11	AKE, BAU, BDH	02/00→01/05	UC45A
2.5 TDI quattro	6	132	2496	11	AKE, BAU, BDH	02/00→01/05	UC45A
2.7 TDI	6	120	2698	11	BSG	11/04→	UC45A
2.7 TDI quattro	6	120	2698	4,4	BSG	06/05→	UY7A
2.7 TDI	6	132	2698	11	BPP	11/04→	UC45A
2.7 TDI quattro	6	132	2698	4,4		11/04→	UY7A
3.0 TDI quattro	6	155	2967	4,4	BNG	05/04→	UY7A
3.0 TDI quattro	6	165	2967	4,4	BMK	05/04→	UY7A

### A6 Avant

1.9 TDI	4	66	1896	11	1Z, AHU	06/94→12/97	UC31A
1.9 TDI	4	81	1896	11	AFN, AVG	02/98→04/01	UC31A
1.9 TDI	4	85	1896	11	AJM	07/00→01/05	UC31A
1.9 TDI	4	96	1896	11	AVF, AWX	08/01→01/05	UC31A
2.0 TDI	4	100	1968	4,4	BNA, BRF, CAGB	06/05→	UC03F
2.0 TDI	4	103	1968	4,4	BLB, BRE	06/05→	UC03F
2.5 TDI	6	84	2496	11	AAT	01/95→12/97	UC31A
2.5 TDI	6	85	2496	11	AAT	06/94→12/97	UC31A
2.5 TDI	6	103	2496	11	AEL	08/94→12/97	UC31A
2.5 TDI quattro	6	103	2496	11	AEL	07/95→12/97	UC31A
2.5 TDI	6	110	2496	11	AFB, AKN	12/97→01/05	UC45A
2.5 TDI quattro	6	110	2496	11	AFB, AKN	12/97→01/05	UC45A
2.5 TDI	6	114	2496	11	AYM	08/01→	UC45A
2.5 TDI	6	120	2496	11	BCZ, BDG, BFC	07/02→	UC45A
2.5 TDI quattro	6	132	2496	11	AKE, BAU, BDH	02/00→01/05	UC45A
2.7 TDI	6	120	2698	11	BSG®4F5028000	03/05→	UC45A
2.7 TDI quattro	6	120	2698	4,4	BSG	06/05→	UY7A
2.7 TDI	6	132	2698	4,4		03/05→	UY7A
2.7 TDI quattro	6	132	2698	4,4		03/05→	UY7A
3.0 TDI quattro	6	155	2967	4,4	BNG	03/05→	UY7A
3.0 TDI quattro	6	165	2967	4,4	BMK	03/05→	UY7A

### A8

2.5 TDI	6	110	2496	11	AFB, AKN	01/97→04/00	UC45A
2.5 TDI quattro	6	110	2496	11	AFB, AKN	07/97→04/00	UC45A



		kW	cc	V			
2.5 TDI	6	132	2496	11	AKE	09/00→09/02	UC45A
2.5 TDI quattro	6	132	2496	11	AKE	09/00→09/02	UC45A
3.0 TDI quattro	6	155	2967	4,4	BNG	11/03→	UY7A
3.0 TDI quattro	6	171	2967	11	ASB	08/03→	UC45A
3.3 TDI quattro	8	165	3328	11	AKF	06/00→09/02	UC45A
4.0 TDI quattro	8	202	3936	11	ASE	03/03→	UC45A

### ALLROAD

2.5 TDI quattro	6	120	2496	11	BCZ	05/03→08/05	UC45A
2.5 TDI quattro	6	132	2496	11	AKE, BAU	05/00→08/05	UC45A

### CABRIOLET

1.9 TDI	4	66	1896	11	1Z, AHU	06/95→08/00	UC31A
---------	---	----	------	----	---------	-------------	-------

## BMW

### 1 (E87)

118d	4	90	1995	5	M47N204D4	09/04→	UC02F
120d	4	120	1995	5	M47N204D4, N47D204	09/04→	UC02F

### 3 (E36)

318tds	4	66	1665	11	M 41 D 18 (Inter.)	01/95→02/98	UX20A
325td	6	85	2497	11	M 51 D 25	09/91→02/98	UX20A
325tds	6	105	2503	11	M 51 D 25 (Inter.)	05/93→02/98	UX20A

### 3 Compact (E36)

318tds	4	66	1665	11	M 41 D 18 (Inter.)	01/95→08/00	UX20A
--------	---	----	------	----	--------------------	-------------	-------

### 3 Touring (E36)

318tds	4	66	1665	11	M 41 D 18 (Inter.)	01/95→10/99	UX20A
325tds	6	105	2503	11	M 51 D 25 (Inter.)	01/95→10/99	UX20A

### 3 (E46)

318d	4	85	1951	5	M47204D1	09/01→03/03	UC02F
318d	4	85	1995	5	M47N204D4	03/03→02/05	UC02F
320d	4	100	1951	11	M 47 D 20, M47204D1	04/98→09/01	UC26A
320d	4	110	1995	5	M47N204D4	09/01→02/05	UC02F
330d	6	135	2926	11	M 57 D 30	10/99→02/05	UC26A
330xd	6	135	2926	11	M 57 D 30	06/00→02/05	UC26A
330d	6	150	2993	5	M57N306D2	03/03→02/05	UC02F
330xd	6	150	2993	5	M57N306D2	03/03→02/05	UC02F

### 3 Compact (E46)

318td	4	85	1995	5	M47N204D4	03/03→02/05	UC02F
320td	4	110	1995	5	M47N204D4	09/01→02/05	UC02F

**BMW**
**3 Convertible (E46)**

320Cd	4	110	1995	5	M47N204D4	02/05→	UC02F
330Cd	6	150	2993	5	M57N306D2	08/05→	UC02F

**3 Coupe (E46)**

320Cd	4	110	1995	5	M47N204D4	11/03→	UC02F
330Cd	6	150	2993	5	M57N306D2	03/03→	UC02F

**3 Touring (E46)**

318d	4	85	1951	5	M47204D1, M47D20	03/02→02/05	UC02F
318d	4	85	1995	5	M47N204D4	03/03→02/05	UC02F
320d	4	100	1951	11	M 47 D 20, M47204D1	03/00→09/01	UC26A
320d	4	110	1995	5	M47N204D4	09/01→02/05	UC02F
330d	6	135	2926	11	M 57 D 30	10/99→02/05	UC26A
330xd	6	135	2926	11	M 57 D 30	06/00→02/05	UC26A
330d	6	150	2993	5	M57N306D2	03/03→02/05	UC02F
330xd	6	150	2993	5	M57N306D2	03/03→02/05	UC02F

**3 (E90)**

318d	4	90	1995	5		09/05→	UC02F
320d	4	120	1995	5	M47N204D4, M47N204D5	01/05→	UC02F
325d	6	145	2993	5	M57306D3	09/06→	UC02F
330d	6	170	2993	5		09/05→	UC02F
330xd	6	170	2993	5		09/05→	UC02F

**3 Touring (E91)**

318d	4	90	1995	5		09/05→	UC02F
320d	4	110	1995	5	M47D20TU, M47N204D4	09/05→	UC02F
320d	4	120	1995	5	M47N204D5, N47D20A	09/05→	UC02F
325d	6	145	2993	5	M57 TU2 D30, M57306D3	09/06→	UC02F
330d	6	170	2993	5	M57306D3	09/05→	UC02F
330xd	6	170	2993	5	M57 TU2 D30, M57306D3	09/05→	UC02F

**3 Coupe (E92)**

325d	6	145	2993	5	M57 TU2 D30, N57N306D3	03/07→	UC02F
------	---	-----	------	---	------------------------	--------	-------

**5 (E39)**

525 td	6	85	2497	11	M 51 D 25	01/97→06/03	UX20A
520 d	4	100	1951	11	M 47 D 20, M47204D1	02/00→06/03	UC26A
525 tds	6	105	2503	11	M 51 D 25 (Inter.)	01/96→06/03	UX20A
525 d	6	120	2497	11	M 57 D 25, M57256D1	02/00→06/03	UC26A
530 d	6	142	2926	11	M 57 D 30	08/98→09/00	UC26A
530 d	6	142	2926	11	M 57 D 30	09/00→06/03	UC26A





		kW	cc	V			
<b>BMW</b>							
<b>5 Touring (E39)</b>							
520 d	4	100	1951	11	M 47 D 20, M47204D1	02/00→06/03	<b>UC26A</b>
525 tds	6	105	2503	11	M 51 D 25 (Inter.)	03/97→06/03	<b>UX20A</b>
525 d	6	120	2497	11	M 57 D 25, M57256D1	02/00→06/03	<b>UC26A</b>
530 d	6	135	2926	11	M 57 D 30	08/98→09/00	<b>UC26A</b>
530 d	6	142	2926	11	M 57 D 30	09/00→05/04	<b>UC26A</b>
<b>5 (E60)</b>							
520d	4	120	1995	5	M47N204D5, N47D20A	07/05→	<b>UC02F</b>
525d	6	130	2497	5	M 57 D 25 TU, M57N256D4	06/04→	<b>UC02F</b>
530d	6	160	2993	5	N57306D2	07/03→	<b>UC02F</b>
530d	6	170	2993	5	M57306D3	07/03→	<b>UC02F</b>
530xd	6	170	2993	5	M57306D3	07/05→	<b>UC02F</b>
535d	6	200	2993	5	M57306D4	09/04→	<b>UC02F</b>
<b>5 Touring (E61)</b>							
520d	4	120	1995	5	M47N204D5, N47D20A	07/05→	<b>UC02F</b>
525d	6	130	2497	5	M 57 D 25 TU, M57N256D4	06/04→	<b>UC02F</b>
530d	6	160	2993	5	N57306D2	06/04→	<b>UC02F</b>
530d	6	170	2993	5	M57306D3	07/05→	<b>UC02F</b>
530xd	6	170	2993	5	M57306D3	07/05→	<b>UC02F</b>
535d	6	200	2993	5	M57306D4	09/04→	<b>UC02F</b>
<b>7 (E38)</b>							
725 tds	6	105	2503	11	M 51 D 25 (Inter.)	04/96→11/01	<b>UX20A</b>
730 d	6	135	2926	11	M 57 D 30	08/98→04/00	<b>UC26A</b>
730 d	6	142	2926	11	M57306D1	04/00→11/01	<b>UC26A</b>
<b>7 (E65, E66)</b>							
730 d	6	160	2993	5	N57306D2	10/02→	<b>UC02F</b>
730 Ld	6	170	2993	5	M57306D3, N57N306D2	07/05→	<b>UC02F</b>
<b>X3 (E83)</b>							
2.0 d	4	110	1995	5	M47N204D4	10/04→	<b>UC02F</b>
3.0 d	6	150	2993	5	M54N306D2	01/04→	<b>UC02F</b>
3.0 d	6	160	2993	5	M57N2306D2	01/04→	<b>UC02F</b>
3.0 sd	6	210	2993	5	N57N306D5	09/06→	<b>UC02F</b>
<b>X5 (E53)</b>							
3.0 d	6	135	2925	11	M57306D1	05/01→	<b>UC26A</b>
3.0 d	6	160	2993	5	M57N306D4	12/03→	<b>UC02F</b>
<b>X5 (E70)</b>							
3.0 sd	6	210	2993	5	M57N306D5	09/07→	<b>UC02F</b>



CHRYSLER							
<b>300 C</b>							
3.0 CRD	6	160	2987	4,4	M664	09/05→	UY8A
<b>300 C Touring</b>							
3.0 CRD	6	160	2987	4,4	M664	09/05→	UY8A
<b>PT CRUISER</b>							
2.2 CRD	4	89	2148	11,5	EDJ	03/02→	UC17A
2.2 CRD	4	110	2148	11,5		08/05→	UC17A
<b>VOYAGER I</b>							
2.5 TD	4	87	2500	11	09B, M00	01/92→09/95	UX20A
<b>VOYAGER II</b>							
2.5 TD	4	85	2499	11	425 CLIRS/X	01/95→03/01	UC14A
<b>VOYAGER III</b>							
2.5 CRD	4	105	2499	11,5	ENC, ENJ	02/00→	UC44A
2.8 CRD	4	110	2776	11,5	ENR	06/04→	UC44A

CITROËN							
<b>AX</b>							
1.4 D	4	37	1360	11,5	K9Y (TUD3Y)	08/91→12/97	UX11A
1.4 D	4	38	1360	11,5	K9A (TUD3)	09/88→06/92	UX11A
1.5 D	4	40	1527	11	VJY (TUD5)	08/94→12/97	UC15A
1.5 D	4	43	1527	11	VJZ (TUD5)	08/94→12/97	UC15A
<b>C1</b>							
1.4 HDi	4	40	1398	11	DV4D	06/05→	UY1A
<b>C2</b>							
1.4 HDi	4	50	1398	11	8HX (DV4TD)	09/03→	UY1A
<b>C3</b>							
1.4 HDi	4	50	1398	11	8HX (DV4TD)	02/02→	UY1A
1.4 16V HDi	4	66	1398	11	8HY (DV4TED4)	02/02→	UY1A
1.6 16V HDi	4	66	1560	11	9HX (DV6ATED4)	10/05→	UY5A
1.6 16V HDi	4	80	1560	11	DV6TED4	09/05→	UY5A
<b>C3 Pluriel</b>							
1.4 HDi	4	50	1398	11	8HX (DV4TD)	04/04→	UY1A
<b>C4</b>							
1.6 HDi	4	66	1560	11	9HX (DV6ATED4)	11/04→	UY1A
1.6 HDi	4	80	1560	11	9HY (DV6TED4), 9HZ-DV6TED4, DV6TED4	11/04→	UY1A
2.0 HDi	4	100	1997	11	DW10BTED4, RHR (DW10BTED4)	11/04→	UC12A



<b>CITROËN</b>							
<b>C4 Coupe</b>							
		<b>kW</b>	<b>cc</b>	<b>V</b>			
1.6 HDi	4	66	1560	11	9HX (DV6ATED4)	11/04→	<b>UY1A</b>
1.6 HDi	4	80	1560	11	9HY (DV6TED4), 9HZ-DV6TED4, DV6TED4	11/04→	<b>UY1A</b>
2.0 HDi	4	100	1997	11	DW10BTED4, RHR (DW10BTED4)	11/04→	<b>UC12A</b>
<b>C5</b>							
1.6 HDi	4	80	1560	11	DV6TED4	09/04→	<b>UY1A</b>
2.0 HDi	4	66	1997	11	RHY (DW10TD)	03/01→08/04	<b>UC12A</b>
2.0 HDi	4	80	1997	11	RHZ (DW10ATED)	03/01→08/04	<b>UC12A</b>
2.2 HDi	4	98	2179	11	4HX (DW12TED4/FAP)	03/01→08/04	<b>UC12A</b>
2.2 HDi	4	98	2179	11	4HX (DW12TED4/FAP)	09/04→	<b>UC12A</b>
2.0 HDi	4	100	1997	11	DW10BTED4	09/04→	<b>UC41A</b>
<b>C5 Break</b>							
1.6 HDi	4	80	1560	11	DV6TED4	09/04→	<b>UY1A</b>
2.0 HDi	4	66	1997	11	RHY (DW10TD)	06/01→08/04	<b>UC12A</b>
2.0 HDi	4	79	1997	11	RHS (DW10ATED), RHZ (DW10ATED)	06/01→08/04	<b>UC12A</b>
2.2 HDi	4	98	2179	11	4HX (DW12TED4/FAP)	06/01→08/04	<b>UC12A</b>
2.2 HDi	4	98	2179	11	4HX (DW12TED4/FAP)	09/04→	<b>UC12A</b>
2.0 HDi	4	100	1997	11	DW10BTED4	09/04→	<b>UC41A</b>
<b>C6</b>							
2.7 HDi	6	150	2720	11	DT17ED4	09/05→	<b>UY4A</b>
<b>C8</b>							
2.0 HDi	4	79	1997	11	RHM (DW10ATED4), RHT (DW10ATED4), RHW (DW10ATED4)	07/02→	<b>UC12A</b>
2.2 HDi	4	94	2179	11	4HW (DW12TED4)	07/02→	<b>UC12A</b>
<b>EVASION</b>							
1.9 TD	4	66	1905	11	D8B (XUD9TF), DHX (XUD9TF/BTF)	11/94→08/98	<b>UX20A</b>
1.9 TD	4	66	1905	11	D8B (XUD9TF), DHX (XUD9TF/BTF)	09/98→07/02	<b>UX20A</b>
1.9 TD	4	68	1905	11	D8B (XUD9TF)	10/95→12/98	<b>UX20A</b>
2.0 TD	4	68	1998	11		05/97→07/02	<b>UX20A</b>
2.0 HDi	4	80	1997	11	RHZ (DW10ATED)	08/99→07/02	<b>UC12A</b>
2.1 TD	4	80	2088	11	P8C (XUD11BTE)	05/96→07/02	<b>UX20A</b>

**CITROËN**
**SAXO**

1.5 D	4	42	1527	11	VJZ (TUD5)	09/96→06/01	<b>UC15A</b>
1.5 D	4	40	1527	11	VJY (TUD5)	09/96→09/03	<b>UC15A</b>

**XANTIA**

1.9 D	4	50	1905	11	DJZ (XUD9Y)	06/94→01/98	<b>UX20A</b>
1.9 D	4	51	1905	11	D9B (XUD9A/L)	06/94→01/98	<b>UX20A</b>
1.9 SD	4	55	1905	11	DHW (XUD9SD)	02/96→01/98	<b>UX20A</b>
1.9 Turbo D	4	66	1905	11	DHX (XUD9TF/BTF), DHY (XUD9TE/Y)	10/94→01/98	<b>UX20A</b>
2.0 HDI 90	4	66	1997	11	RHY (DW10TD)	03/99→04/03	<b>UC12A</b>
2.0 HDI 109	4	80	1997	11	RHZ (DW10ATED)	02/99→04/03	<b>UC12A</b>
2.1 Turbo D 12V	4	80	2088	11	P8C (XUD11BTE)	06/95→01/98	<b>UX20A</b>

**XANTIA Break**

1.9 SD	4	55	1905	11	DHW (XUD9SD)	04/97→01/98	<b>UX20A</b>
1.9 Turbo D	4	66	1905	11	D8B (XUD9TF), DHX (XUD9TF/BTF), DHY (XUD9TE/Y)	06/95→01/98	<b>UX20A</b>
2.0 HDI 90	4	66	1997	11	RHY (DW10TD)	03/99→04/03	<b>UC12A</b>
2.0 HDI 109	4	80	1997	11	RHZ (DW10ATED)	02/99→04/03	<b>UC12A</b>
2.1 Turbo D 12V	4	80	2088	11	P8C (XUD11BTE)	06/96→01/98	<b>UX20A</b>

**XM**

2.1 TD 12V	4	80	2088	11	P8A (XUD11ATE), P8C (XUD11BTE), PHZ (XUD11ATE), PJZ (XUD11ATE)	05/94→10/00	<b>UX20A</b>
2.5 TD	4	95	2446	11	THY (DK5ATE)	05/94→10/00	<b>UX20A</b>

**XM Break**

2.1 D 12V	4	60	2138	11	P9A (XUD11A)	11/91→06/96	<b>UX20A</b>
2.1 TD 12V	4	80	2088	11	P8A (XUD11ATE), P8C (XUD11BTE), PHZ (XUD11ATE), PJZ (XUD11ATE)	11/91→04/94	<b>UX20A</b>
2.1 TD 12V	4	80	2088	11	P8C (XUD11BTE), PHZ (XUD11ATE), PJZ (XUD11ATE)	05/94→10/00	<b>UX20A</b>
2.5 TD	4	95	2446	11	THY (DK5ATE)	05/94→10/00	<b>UX20A</b>

**XSARA**

1.4 HDi	4	50	1398	11	8HX (DV4TD)	01/03→03/05	<b>UY1A</b>
1.5 D	4	42	1527	11	VJZ (TUD5)	04/97→09/00	<b>UC15A</b>
1.8 D	4	43	1769	11	161A (XUD7), A9A (XUD7)	04/97→09/00	<b>UX20A</b>
1.8 TD	4	66	1761	11		10/97→09/00	<b>UX20A</b>



<b>CITROËN</b>							
1.9 D	4	50	1905	11	DJY (XUD9A)	04/97→09/00	<b>UX20A</b>
1.9 D	4	51	1868	11	WJY (DW8B), WJZ (DW8)	07/98→03/05	<b>UC15A</b>
1.9 SD	4	55	1905	11	DHV (XUD9BSD)	01/98→09/00	<b>UX20A</b>
1.9 TD	4	66	1905	11	DHY (XUD9TE/Y)	04/97→09/00	<b>UX20A</b>
2.0 HDi 90	4	66	1997	11	RHY (DW10TD)	02/99→03/05	<b>UC12A</b>
2.0 HDi 109	4	80	1997	11	RHZ (DW10ATED)	05/01→03/05	<b>UC12A</b>
<b>XSARA Break</b>							
1.4 HDi	4	50	1398	11	8HX (DV4TD)	01/03→08/05	<b>UY1A</b>
1.5 D	4	42	1527	11	VJZ (TUD5)	10/97→09/00	<b>UC15A</b>
1.8 D	4	43	1769	11	A9A (XUD7)	10/97→09/00	<b>UX20A</b>
1.9 D	4	50	1905	11	DJY (XUD9A)	10/97→09/00	<b>UX20A</b>
1.9 D	4	51	1868	11	WJY (DW8B), WJZ (DW8)	07/98→08/05	<b>UC15A</b>
1.9 D	4	55	1905	11	DHV (XUD9BSD)	01/98→09/00	<b>UX20A</b>
1.9 TD	4	66	1905	11	DHY (XUD9TE/Y)	10/97→09/00	<b>UX20A</b>
2.0 HDi 90	4	66	1997	11	RHY (DW10TD)	02/99→08/05	<b>UC12A</b>
2.0 HDi 109	4	80	1997	11	RHZ (DW10ATED)	05/01→08/05	<b>UC12A</b>
<b>XSARA Coupe</b>							
1.4 HDi	4	50	1398	11	8HX (DV4TD)	01/03→03/05	<b>UY1A</b>
1.9 D	4	50	1905	11	DJY (XUD9A)	02/98→09/00	<b>UX20A</b>
1.9 D	4	51	1868	11	WJY (DW8B), WJZ (DW8)	02/99→03/05	<b>UC15A</b>
1.9 TD	4	66	1905	11	DHY (XUD9TE/Y)	02/98→09/00	<b>UX20A</b>
2.0 HDi 90	4	66	1997	11	RHY (DW10TD)	02/99→03/05	<b>UC12A</b>
2.0 HDi 109	4	80	1997	11	RHZ (DW10ATED)	05/01→03/05	<b>UC12A</b>
<b>XSARA PICASSO</b>							
1.6 HDi	4	66	1560	11		09/05→	<b>UY1A</b>
1.6 HDi	4	80	1560	11	DV6TED4	05/04→	<b>UY1A</b>
2.0 HDi	4	66	1997	11	RHY (DW10TD)	12/99→	<b>UC12A</b>
<b>ZX</b>							
1.8 D	4	44	1769	11	161A (XUD7)	06/93→04/94	<b>UX20A</b>
1.8 D	4	44	1769	11	161A (XUD7)	05/94→06/97	<b>UX20A</b>
1.9 D	4	47	1905	11	DJZ (XUD9Y)	05/94→06/97	<b>UX20A</b>
1.9 D	4	50	1905	11	D9B (XUD9A/U)	06/94→06/97	<b>UX20A</b>
1.9 TD	4	66	1905	11	DHY (XUD9TE/Y)	07/92→04/94	<b>UX20A</b>
1.9 TD	4	66	1905	11	DHY (XUD9TE/Y)	05/94→06/97	<b>UX20A</b>
<b>ZX Break</b>							
1.8 D	4	44	1769	11	161A (XUD7)	10/93→04/94	<b>UX20A</b>
1.8 D	4	44	1769	11	161A (XUD7)	05/94→10/97	<b>UX20A</b>
1.9 D	4	47	1905	11	DJZ (XUD9Y)	10/93→04/94	<b>UX20A</b>
1.9 D	4	47	1905	11	DJZ (XUD9Y)	05/94→10/97	<b>UX20A</b>



### CITROËN

1.9 D	4	50	1905	11	D9B (XUD9A/U)	06/94→10/97	<b>UX20A</b>
1.9 TD	4	66	1905	11	DHY (XUD9TE/Y)	10/93→04/94	<b>UX20A</b>
1.9 TD	4	66	1905	11	DHY (XUD9TE/Y)	05/94→10/97	<b>UX20A</b>

### BERLINGO

1.6 HDI 75	4	55	1560	11	19026	07/05→	<b>UY5A</b>
1.6 HDI 90	4	66	1560	11	19027	07/05→	<b>UY5A</b>
1.8 D	4	43	1769	11	A9A (XUD7)	07/98→	<b>UX20A</b>
1.9 D	4	50	1905	11	D9B (XUD9A/L), DJY (XUD9A)	07/96→	<b>UX20A</b>
1.9 D	4	51	1868	11	WJY (DW8B), WJZ (DW8)	07/98→	<b>UC15A</b>
1.9 D 4WD	4	51	1868	11	WJZ (DW8)	07/98→	<b>UC15A</b>
2.0 HDI 90	4	66	1997	11	RHY (DW10TD)	12/99→	<b>UC12A</b>

### JUMPER

1.9 D	4	50	1905	11	DJY (XUD9A)	07/99→04/02	<b>UX20A</b>
1.9 D	4	51	1905	11	D9B (XUD9A/U)	02/94→04/02	<b>UX20A</b>
1.9 TD	4	66	1905	11	DHX (XUD9TF/BTF)	09/98→04/02	<b>UX20A</b>
1.9 TD	4	66	1905	11	DHX (XUD9TF/BTF)	03/94→08/98	<b>UX20A</b>
1.9 TD	4	68	1905	11	D8C (XUD9UTF)	03/94→08/98	<b>UX20A</b>
1.9 TD	4	68	1905	11	D8C (XUD9UTF)	09/98→04/02	<b>UX20A</b>
1.9 TD 4x4	4	68	1905	11	D8C (XUD9UTF)	03/94→08/98	<b>UX20A</b>
1.9 TD 4x4	4	68	1905	11	D8C (XUD9UTF)	09/98→04/02	<b>UX20A</b>
2.0 HDI	4	62	1997	11	DW10UTD	11/01→04/02	<b>UC12A</b>
2.0 HDi	4	62	1997	11	DW10UTD	04/02→	<b>UC12A</b>
2.2 HDi	4	74	2179	11	DW12TED	04/02→	<b>UC12A</b>
2.5 D	4	63	2446	11	T9A (DJ5)	03/94→04/02	<b>UX20A</b>
2.5 D 4x4	4	63	2446	11	T9A (DJ5)	03/00→04/02	<b>UX20A</b>
2.5 TD	4	76	2446	11	T8A (DJ5T)	03/94→04/02	<b>UX20A</b>
2.5 TD 4x4	4	76	2446	11	T8A (DJ5T)	08/96→04/02	<b>UX20A</b>
2.5 TDi	4	79	2446	11	THX (DJ5TED)	12/96→11/00	<b>UC40A</b>
2.5 TDi 4x4	4	79	2446	11	THX (DJ5TED)	03/00→11/00	<b>UC40A</b>
2.8 HDi	4	94	2798	11	8140.43S	09/00→04/02	<b>UC37A</b>
2.8 HDi 4x4	4	94	2798	11	8140.43S	09/00→04/02	<b>UC37A</b>
2.8 HDi	4	94	2798	11	8140.43S	04/02→	<b>UC37A</b>
2.8 HDi 4x4	4	94	2798	11	8140.43S	04/02→	<b>UC37A</b>
2.8 HDi	4	107	2798	11	8140.43N	05/04→	<b>UC37A</b>

### JUMPY

1.9 D 70	4	51	1868	11	WJZ (DW8)	04/98→	<b>UC15A</b>
1.9 D	4	51	1905	11	D9B (XUD9A/U)	10/95→04/98	<b>UX20A</b>
1.9 TD	4	66	1905	11	DHX (XUD9TF/BTF)	10/95→	<b>UX20A</b>



<b>CITROËN</b>							
1.9 TD	4	68	1905	11	D8B (XUD9TF)	04/96→08/98	<b>UX20A</b>
1.9 TD	4	68	1905	11	D8B (XUD9TF)	09/98→	<b>UX20A</b>
2.0 HDi 95	4	69	1997	11	RHX	10/99→	<b>UC12A</b>
2.0 HDi 110	4	80	1997	11	RHZ (DW10ATED)	03/00→	<b>UC12A</b>

<b>DACIA</b>							
<b>LOGAN</b>							
1.5 dCi	4	48	1461	11	K9K 790	09/05→	<b>UC31A</b>
1.5 dCi	4	50	1461	11	K9K 792	02/07→	<b>UC31A</b>
1.5 dCi	4	63	1461	11	K9K 796	09/07→	<b>UC31A</b>
<b>LOGAN MCV</b>							
1.5 dCi	4	50	1461	11	K9K 792	02/07→	<b>UC31A</b>
1.5 dCi	4	63	1461	11	K9K 796	09/07→	<b>UC31A</b>

<b>DAEWOO</b>							
<b>KORANDO</b>							
2.9 TD 10V	5	88	2874	11,5	MB-OM 601 29TD	01/99→	<b>UX13A</b>
<b>MUSSO</b>							
2.9 TD 10V	5	88	2874	11,5	MB-OM 601 29TD	01/99→	<b>UX13A</b>

<b>DODGE</b>							
<b>AVENGER</b>							
2.0 CRD	4	103	1968	4,4	ECD	06/07→	<b>UC03F</b>
<b>CALIBER</b>							
2.0 CRD	4	103	1968	4,4	ECD	06/06→	<b>UC03F</b>
<b>CARAVAN II</b>							
2.5 TD	4	85	2499	11	ENC	01/95→03/01	<b>UX20A</b>

<b>FIAT</b>							
<b>BRAVA</b>							
1.9 D	4	48	1929	11	160 A7.000	10/95→03/96	<b>UX20A</b>
1.9 TD 75 S	4	55	1910	11	182 A8.000	03/96→10/01	<b>UC4A</b>
1.9 JTD	4	74	1910	11	182 B9.000	09/00→10/01	<b>UC19A</b>
1.9 TD 100 S	4	74	1910	11	182 A7.000	03/96→10/01	<b>UC4A</b>
1.9 JTD 105	4	77	1910	11	182 B4.000	12/98→10/99	<b>UC11A</b>
1.9 JTD 105	4	77	1910	11	182 B4.000	11/99→10/01	<b>UC19A</b>



## FIAT

### BRAVO

1.9 D	4	48	1929	11	160 A7.000	10/95→03/96	UX20A
1.9 TD 75 S	4	55	1910	11	182 A8.000	03/96→10/01	UC4A
1.9 JTD	4	74	1910	11	182 B9.000	09/00→10/01	UC19A
1.9 TD 100 S	4	74	1910	11	182 A7.000	03/96→10/01	UC4A
1.9 JTD 105	4	77	1910	11	182 B4.000	12/98→10/99	UC11A
1.9 JTD 105	4	77	1910	11	182 B4.000	11/99→10/01	UC19A

### CROMA (154)

1900 Turbo D i.d.	4	69	1929	11	154 D1.000	11/92→12/96	UC2A
2500 TDE	4	77	2500	11	8144.97 S	12/91→08/96	UX20A

### CROMA (194)

1.9 D Multijet	4	88	1910	11	939A1.000	06/05→	UC43A
1.9 D Multijet	4	110	1910	11	939A2.000	06/05→	UY3A
2.4 D Multijet	5	147	2387	11	939A3.000	06/05→	UY3A

### ELBA

1.3 D	4	33	1301	11	127 A5.000	04/86→10/92	UX20A
1.7 D	4	43	1698	11	146 B2.000	04/89→12/96	UX20A

### GRANDE PUNTO

1.3 D Multijet	4	55	1248	11	199 A2.000	10/05→	UY2A
1.3 D Multijet	4	66	1248	11	199 A3.000	10/05→	UY2A
1.9 D Multijet	4	88	1910	11	939A1.000	10/05→	UC19A
1.9 D Multijet	4	96	1910	11	199 A5.000	10/05→	UC19A

### IDEA

1.3 JTD	4	51	1248	11	188 A9.000	01/04→	UY2A
1.9 JTD	4	74	1910	11	188 B2.000	01/04→	UC19A

### MAREA

1.9 TD 75	4	55	1910	11	182 A8.000	09/96→	UC4A
1.9 TD 100	4	74	1910	11	182 A7.000	09/96→	UC4A
1.9 JTD 105	4	77	1910	11	182 B4.000	04/99→10/99	UC11A
1.9 JTD 105	4	77	1910	11	182 B4.000	11/99→01/01	UC19A
1.9 JTD 110	4	81	1910	11	186 A6.000	01/01→	UC19A
2.4 TD 125	5	91	2387	11	185 A2.000	09/96→04/99	UC4A
2.4 JTD 130	5	96	2387	11	185 A6.000, 839 A5.000	04/99→10/99	UC11A
2.4 JTD 130	5	96	2387	11	185 A6.000, 839 A5.000	11/99→	UC19A

### MAREA Weekend

1.9 TD 75	4	55	1910	11	182 A8.000	09/96→	UC4A
1.9 TD 100	4	74	1910	11	182 A7.000	09/96→	UC4A
1.9 JTD 105	4	77	1910	11	182 B4.000	04/99→10/99	UC11A
1.9 JTD 105	4	77	1910	11	182 B4.000	11/99→01/01	UC19A





<b>FIAT</b>								
1.9 JTD 110	4	81	1910	11	186 A6.000	01/01→		<b>UC19A</b>
2.4 TD 125	5	91	2387	11	185 A2.000	09/96→04/99		<b>UC4A</b>
2.4 JTD 130	5	96	2387	11	185 A6.000, 839 A5.000	04/99→10/99		<b>UC11A</b>
2.4 JTD 130	5	96	2387	11	185 A6.000, 839 A5.000	11/99→		<b>UC19A</b>
<b>MULTIPLA</b>								
1.9 JTD 105	4	77	1910	11	182 B4.000	04/99→10/99		<b>UC11A</b>
1.9 JTD 105	4	77	1910	11	182 B4.000	11/99→		<b>UC19A</b>
1.9 JTD 110	4	81	1910	11	186 A6.000	03/01→07/02		<b>UC19A</b>
1.9 JTD 115	4	85	1910	11	186 A8.000	07/02→		<b>UC19A</b>
<b>PALIO Weekend</b>								
1.7 TD	4	51	1698	11	176 A3.000	04/96→03/01		<b>UX20A</b>
1.9 D	4	46	1910	11	223 A6.000	03/01→		<b>UX21A</b>
<b>PANDA</b>								
1.3 D Multijet	4	51	1248	11	188 A9.000	09/03→		<b>UY2A</b>
1.3 D Multijet 4x4	4	51	1248	11	188 A9.000	10/04→		<b>UY2A</b>
<b>PUNTO (176)</b>								
1.7 D	4	42	1698	11	176 B3.000	04/94→09/97		<b>UX20A</b>
1.7 TD	4	46	1698	11	176 B7.000	09/96→09/99		<b>UX20A</b>
1.7 TD	4	51	1698	11	176 A3.000	01/94→09/96		<b>UX20A</b>
1.7 TD	4	52	1698	11	176 A5.000	01/94→09/99		<b>UX20A</b>
<b>PUNTO (188)</b>								
1.3 JTD 16V	4	51	1248	11	188 A9.000	06/03→		<b>UY2A</b>
1.9 JTD 80	4	59	1910	11	188 A2.000	09/99→		<b>UC19A</b>
1.9 DS 60	4	44	1910	11	188 A3.000	09/99→		<b>UX21A</b>
1.9 JTD	4	63	1910	11	188 A7.000	10/01→		<b>UC19A</b>
1.9 JTD	4	74	1910	11	188 B2.000	06/03→		<b>UC19A</b>
<b>STILO</b>								
1.9 JTD	4	59	1910	11	192 A3.000	02/02→		<b>UC19A</b>
1.9 D Multijet	4	74	1910	11	192 A9.000	09/05→		<b>UC19A</b>
1.9 JTD	4	85	1910	11	192 A1.000, 937A7.000	10/01→		<b>UC19A</b>
1.9 D Multijet	4	88	1910	11	192 A8.000	09/05→		<b>UC43A</b>
1.9 JTD	4	103	1910	11	192 A5.000	01/04→		<b>UY3A</b>
1.9 D Multijet	4	110	1910	11	937A5.000	09/05→		<b>UY3A</b>
<b>STRADA</b>								
1.7 TD	4	51	1698	11	176 A3.000	06/99→		<b>UX20A</b>
1.9 D	4	46	1910	11	223 A6.000	12/00→		<b>UX21A</b>
1.9 JTD	4	59	1910	11	188 A2.000	04/03→		<b>UC19A</b>



## FIAT

### TEMPRA

1.9 D	4	48	1929	11	160 A7.000	07/91→08/96	<b>UX20A</b>
1.9 TD	4	59	1929	11	160 B6.046	07/92→08/96	<b>UX20A</b>
1.9 TD	4	66	1929	11	160 A6.000, 160 D1.000	05/90→08/96	<b>UX20A</b>

### TIPO

1.7 D	4	43	1697	11	149 B4.000	01/88→10/94	<b>UX20A</b>
1.7 D	4	45	1697	11		01/88→10/95	<b>UX20A</b>
1.9 D	4	48	1929	11	160 A7.000	07/91→08/96	<b>UX20A</b>
1.9 TD	4	59	1929	11	160 B6.046	03/92→06/93	<b>UX20A</b>
1.9 TD	4	66	1929	11	160 A6.000, 160 A6.046, 160 D1.000	09/90→04/95	<b>UX20A</b>

### ULYSSE

1.9 TD	4	66	1905	11	DHX (XUD9TF/L)	02/95→08/02	<b>UX20A</b>
2.0 JTD	4	80	1997	11	RHZ	10/99→08/02	<b>UC12A</b>
2.0 JTD	4	79	1997	11	RHM(DW10ATED4)	05/03→	<b>UC12A</b>
2.0 JTD	4	80	1997	11	RHW(DW10ATED4)	08/02→	<b>UC12A</b>
2.1 TD	4	80	2088	11	P8C	03/96→10/99	<b>UX20A</b>
2.2 JTD	4	94	2179	11	4HW(DW12ATED4)	08/02→	<b>UC12A</b>

### DOBLO

1.3 D Multijet	4	62	1248	11	223 A9.000	10/05→	<b>UY2A</b>
1.9 D	4	46	1910	11	223 A6.000	03/01→	<b>UX21A</b>
1.9 JTD	4	74	1910	11	182 B9.000, 223 B2.000	10/01→	<b>UC19A</b>
1.9 JTD	4	77	1910	11	223 A7.000, 223 B1.000	07/03→	<b>UC19A</b>
1.9 D Multijet	4	88	1910	11	186A9.000	10/05→	<b>UC43A</b>

### DOBLO Cargo

1.3 JTD 16V	4	51	1248	11	188 A9.000	05/04→	<b>UY2A</b>
1.3 D Multijet	4	55	1248	11	199 A2.000	10/05→	<b>UY2A</b>
1.9 D	4	46	1910	11	223 A6.000	03/01→	<b>UX21A</b>
1.9 JTD	4	74	1910	11	182 B9.000	10/01→	<b>UC19A</b>
1.9 JTD	4	77	1910	11	223 A7.000, 223 B1.000	07/03→	<b>UC19A</b>

### DUCATO (230L)

1.9 D	4	50	1905	11	DJY	04/98→04/02	<b>UC15A</b>
1.9 D	4	51	1929	11	230 A2.000	03/94→04/02	<b>UX20A</b>
1.9 TD CAT	4	59	1929	11	230 A4.000	08/94→04/02	<b>UX20A</b>
1.9 TD	4	60	1929	11	230 A3.000	03/94→04/02	<b>UX20A</b>
1.9 TD	4	66	1905	11	DHX (XUD9TF/L)	04/98→04/02	<b>UX20A</b>
2.0 JTD	4	62	1997	11	RHV (DW10)	10/01→04/02	<b>UC12A</b>
2.5 D	4	62	2500	11,5	8140.67	03/94→04/02	<b>UX11A</b>
2.8 D	4	64	2800	11	8140.63	05/98→04/02	<b>UC37A</b>



			kW	cc	V			
<b>FIAT</b>								
2.8 D 4x4	4	64	2800	11	8140.63		08/98→04/02	UC37A
2.8 TDI	4	90	2800	11	8140.43		10/97→04/02	UC37A
2.8 TDI 4x4	4	90	2800	11	8140.43		06/99→04/02	UC37A
2.8 JTD	4	94	2798	11	8140.43S		11/00→04/02	UC37A
2.8 JTD 4x4	4	94	2798	11	8140.43S		11/00→04/02	UC37A
<b>DUCATO (244)</b>								
2.0 JTD	4	62	1997	11	RHV (DW10)		04/02→	UC12A
2.3 JTD	4	81	2286	11	F1AE0481C		04/02→	UY6A
2.8 JTD	4	94	2798	11	8140.43S		04/02→	UC37A
2.8 JTD 4x4	4	94	2798	11	8140.43S		07/02→	UC37A
<b>DUCATO (290)</b>								
1.9 D	4	52	1929	11	149 B1.000		07/90→03/94	UX20A
1.9 TD	4	60	1929	11	280 A1.000		03/89→03/94	UX20A
2.5 D 4x4	4	55	2500	11	8144.67		07/90→03/94	UX20A
2.5 TD	4	70	2500	11	8140.27		07/90→03/94	UX20A
2.5 TD 4x4	4	70	2500	11	8140.27		07/90→03/94	UX20A
<b>FIORINO</b>								
1.7 D	4	42	1697	11	146 B2.000		10/93→10/99	UX20A
1.7 D	4	44	1698	11	149 B3.000		05/88→10/99	UX20A
1.7 TD	4	46	1698	11	146 D7.000		01/97→05/01	UX20A
<b>SCUDO</b>								
1.9 D	4	51	1905	11	D9B		02/96→	UX20A
1.9 D	4	51	1868	11	WJZ (DW8)		04/98→	UC15A
1.9 TD	4	66	1905	11	DHX (XUD9TF/L)		02/96→	UX20A
1.9 TD	4	68	1905	11	D8B		02/98→	UX20A
2.0 JTD	4	69	1997	11	RHX		12/99→	UC12A
2.0 JTD	4	80	1997	11	RHZ		12/02→	UC12A
<b>FORD</b>								
<b>ESCORT '81</b>								
1.6 D	4	40	1608	11	LTA		02/84→02/86	UX12A
<b>ESCORT '86</b>								
1.6 D	4	40	1608	11	LTA		02/86→07/90	UX12A
<b>ESCORT III</b>								
1.6 D	4	40	1608	11	LTA		02/84→12/85	UX12A
<b>ESCORT IV</b>								
1.6 D	4	40	1608	11	LTC		01/86→01/89	UX12A
<b>ESCORT CLASSIC</b>								
1.8 TD	4	66	1753	11,5	RFD, RFK		10/98→07/00	UX11A



		kW	cc	V			
<b>FORD</b>							
<b>ESCORT V</b>							
1.8 D	4	44	1753	11,5	RTE, RTF, RTH	07/90→12/92	<b>UX11A</b>
<b>ESCORT VI</b>							
1.8 D	4	44	1753	11,5	RTE, RTF, RTH	09/92→01/95	<b>UX11A</b>
1.8 TD	4	66	1753	11,5	RFD, RFK, RFS	02/93→01/95	<b>UX11A</b>
<b>ESCORT VII</b>							
1.8 D	4	44	1753	11,5	RTE, RTF, RTH	01/95→02/99	<b>UX11A</b>
1.8 Turbo D	4	51	1753	11,5	RVA	12/95→08/99	<b>UX19A</b>
1.8 TD	4	66	1753	11,5	RFD, RFK	01/95→02/99	<b>UX11A</b>
<b>FIESTA II</b>							
1.6 D	4	40	1608	11	LTB	04/84→02/89	<b>UX12A</b>
<b>FIESTA III</b>							
1.8 D	4	44	1753	11,5	RTC, RTD, RTG	03/89→12/95	<b>UX11A</b>
1.8 TD	4	57	1753	11,5		03/93→12/95	<b>UX11A</b>
<b>FIESTA IV</b>							
1.8 D	4	44	1753	11,5	RTJ, RTK	08/95→04/00	<b>UX19A</b>
1.8 DI	4	55	1753	11,5	RTN, RTP, RTQ	04/00→01/02	<b>UX19A</b>
<b>FIESTA V</b>							
1.4 TDCi	4	50	1399	11	F6JA, F6JB	11/01→	<b>UY1A</b>
1.6 TDCi	4	66	1560	11	HHJA, HHJB	11/04→	<b>UY1A</b>
<b>FOCUS</b>							
1.8 DI / TDDi	4	55	1753	11	BHDA, BHDB	08/99→11/04	<b>UC8A</b>
1.8 Turbo DI / TDDi	4	66	1753	10	C9DA, C9DB, C9DC	10/98→11/04	<b>UC22A</b>
1.8 TDCi	4	74	1753	10	FFDA	09/02→11/04	<b>UC22A</b>
1.8 TDCi	4	85	1753	10	F9DA, F9DB	03/01→11/04	<b>UC22A</b>
<b>FOCUS II</b>							
1.6 TDCi	4	66	1560	11	HHDA, HHDB	01/05→	<b>UY1A</b>
1.6 TDCi	4	80	1560	11	G8DA, G8DB	11/04→	<b>UY1A</b>
1.8 TDCi	4	85	1753	10	KKDA	01/05→	<b>UC22A</b>
2.0 TDCi	4	100	1997	11	G6DA, G6DB, G6DD	11/04→	<b>UC41A</b>
<b>FOCUS C-MAX</b>							
1.6 TDCi	4	66	1560	11	HHDA, HHDB	02/05→03/07	<b>UY1A</b>
1.6 TDCi	4	80	1560	11	G8DA, G8DB	10/03→03/07	<b>UY1A</b>
1.8 TDCi	4	85	1753	10	KKDA	01/05→03/07	<b>UC22A</b>
2.0 TDCi	4	100	1997	11	G6DA, G6DB, G6DD	10/03→03/07	<b>UC41A</b>
<b>FUSION</b>							
1.4 TDCi	4	50	1399	11	F6JA, F6JB	08/02→	<b>UY1A</b>
1.6 TDCi	4	66	1560	11	HHJA, HHJB	11/04→	<b>UY1A</b>



<b>FORD</b>							
<b>GALAXY</b>							
		<b>kW</b>	<b>cc</b>	<b>V</b>			
1.8 TDCi	4	74	1753	10	FFWA	05/06→	<b>UC22A</b>
1.8 TDCi	4	92	1753	10	QYWA	05/06→	<b>UC22A</b>
1.9 TDI	4	66	1896	11	1Z, AHU, ANU	03/95→10/01	<b>UC31A</b>
1.9 TDI	4	66	1896	11	1Z, AHU, ANU	11/01→	<b>UC14A</b>
1.9 TDI	4	81	1896	11	AFN, AVG	08/97→04/00	<b>UC31A</b>
1.9 TDI	4	85	1896	11	AUY	04/00→09/01	<b>UC31A</b>
1.9 TDI	4	85	1896	11	AUY	10/01→	<b>UC14A</b>
1.9 TDI	4	96	1896	11	ASZ	02/03→	<b>UC14A</b>
1.9 TDI	4	110	1896	11	BTB	05/05→	<b>UC14A</b>
2.0 TDCi	4	85	1997	11		11/07→	<b>UC41A</b>
2.0 TDCi	4	96	1997	11	AZWA	05/06→	<b>UC41A</b>
2.0 TDCi	4	103	1997	11	QXWA, QXWB	05/06→	<b>UC41A</b>
<b>MONDEO I</b>							
1.8 TD	4	65	1753	11,5	RFM, RFN	06/93→08/96	<b>UX11A</b>
1.8 TD	4	66	1753	11,5	RFM, RFN	10/95→08/96	<b>UX11A</b>
<b>MONDEO II</b>							
1.8 TD	4	66	1753	11,5	RFN	09/96→11/00	<b>UX19A</b>
<b>MONDEO III</b>							
2.0 16V DI / TDDi / TDCi	4	66	1998	11,5	D5BA, SDBA	11/00→	<b>UC27A</b>
2.0 16V TDDi / TDCi	4	85	1998	11,5	D6BA, HJBA, HJBB, HJBC	11/00→	<b>UC27A</b>
2.0 TDCi	4	96	1998	11,5	FMBA, N7BA	10/01→	<b>UC27A</b>
2.2 TDCi	4	114	2198	11,5	QJBA, QJBB	09/04→	<b>UC27A</b>
<b>MONDEO IV</b>							
1.8 TDCi	4	74	1753	10		03/07→	<b>UC22A</b>
<b>ORION</b>							
1.6 D	4	40	1608	11	LTA	02/84→03/86	<b>UX12A</b>
<b>ORION II</b>							
1.6 D	4	40	1608	11	LTC	12/85→01/89	<b>UX12A</b>
<b>ORION III</b>							
1.8 D	4	44	1753	11,5	RTE, RTF, RTH	11/90→12/93	<b>UX11A</b>
1.8 TD	4	66	1753	11,5	RFD, RFK	03/92→12/93	<b>UX11A</b>
<b>SCORPIO I</b>							
2.5 TD	4	68	2498	11	SFA, SFB	09/91→07/93	<b>UX20A</b>
2.5 TD	4	85	2500	11	SCB	08/93→09/94	<b>UX20A</b>
<b>SCORPIO II</b>							
2.5 TD	4	85	2500	11	SCC	10/94→08/98	<b>UC14A</b>
2.5 TD	4	92	2500	11	VM	09/96→08/98	<b>UC14A</b>

**FORD**
**SIERRA**

1.8 TD	4	55	1753	11,5	RFA, RFB, RFL	08/88→02/93	<b>UX11A</b>
2.3 D	4	49	2304	11	YTR	01/87→02/93	<b>UX20A</b>

**S-MAX**

1.8 TDCi	4	92	1753	10	QYWA	05/06→	<b>UC22A</b>
2.0 TDCi	4	85	1997	11		11/07→	<b>UC41A</b>
2.0 TDCi	4	96	1997	11	AZWA	05/06→	<b>UC41A</b>
2.0 TDCi	4	103	1997	11	QXWB	05/06→	<b>UC41A</b>

**TOURNEO CONNECT**

1.8 Di	4	55	1753	10	BHPA	06/02→	<b>UC22A</b>
1.8 Turbo Di	4	66	1753	10	HCPA, HCPB	06/02→	<b>UC22A</b>
1.8 TDCi	4	81	1753	10	RWPA	08/06→	<b>UC22A</b>

**TRANSIT**

1.8 Di	4	55	1753	10	BHPA	09/02→	<b>UC22A</b>
1.8 TDCi	4	66	1753	10	HCPA, HCPB	09/02→	<b>UC22A</b>
1.8 TDCi	4	81	1753	10	RWPA	08/06→	<b>UC22A</b>
2.0 DI	4	55	1998	11,5	D3FA	08/00→	<b>UC27A</b>
2.0 DI	4	63	1998	11,5	F3FA	08/00→	<b>UC27A</b>
2.0 DI	4	74	1998	11,5	ABFA	08/00→	<b>UC27A</b>
2.0 TDCi	4	92	1998	11,5	F1FA	08/02→	<b>UC27A</b>
2.4 DI [RWD]	4	55	2402	11,5	F4FA	01/00→	<b>UC27A</b>
2.4 DI	4	66	2402	11,5	D2FA, D2FB, D2FE	01/00→	<b>UC27A</b>
2.4 TDE	4	85	2402	11,5	FXFA	03/04→	<b>UC27A</b>
2.4 DI [RWD]	4	88	2402	11,5	D4FA	01/00→	<b>UC27A</b>
2.4 TDE	4	92	2402	11,5	DOFA	07/01→	<b>UC27A</b>
2.4 TDCi	4	101	2402	11,5	H9FA	03/04→	<b>UC27A</b>

**HONDA**
**ACCORD VI**

2.0 TDi	4	77	1994	11	20T2N	04/96→10/98	<b>UC8A</b>
---------	---	----	------	----	-------	-------------	-------------

**ACCORD VII**

2.0 Turbo DI	4	77	1994	11	20T2N	02/99→12/02	<b>UC8A</b>
--------------	---	----	------	----	-------	-------------	-------------

**CIVIC V**

2.0 i TD	4	63	1994	11	20T2R	01/97→02/01	<b>UC8A</b>
2.0 i D	4	77	1994	11	20T2N	04/98→02/01	<b>UC8A</b>

**CIVIC VI**

1.7 CTDi	4	74	1686	11	4EE-2	01/02→09/05	<b>UZ2A</b>
----------	---	----	------	----	-------	-------------	-------------



kW

cc

V

MAGNETI  
MARELLI**HYUNDAI****ACCENT**

1.5 CRDi	3	60	1493	11	D3-EA	01/02→	UC33A
----------	---	----	------	----	-------	--------	-------

**ELANTRA**

2.0 CRDi	4	83	1991	11	D4EA	04/01→	UC33A
----------	---	----	------	----	------	--------	-------

**GALLOPER II**

2.5 TD	4	65	2476	11	D4BA	08/98→	UZ4A
--------	---	----	------	----	------	--------	------

**GETZ**

1.5 CRDi	3	60	1493	11	D3-EA	03/03→	UC33A
----------	---	----	------	----	-------	--------	-------

**MATRIX**

1.5 CRDi	3	60	1496	11	D3-EA	10/01→	UC33A
----------	---	----	------	----	-------	--------	-------

**SANTA FE**

2.0 CRDi	4	83	1991	11	D4EA	08/01→	UC33A
----------	---	----	------	----	------	--------	-------

2.0 CRDi 4x4	4	83	1991	11	D4EA	04/01→	UC33A
--------------	---	----	------	----	------	--------	-------

**TERRACAN**

2.9 CRDi	4	110	2902	11		12/01→	UZ4A
----------	---	-----	------	----	--	--------	------

2.9 CRDi	4	120	2902	11	J3	11/03→	UZ4A
----------	---	-----	------	----	----	--------	------

**TRAJET**

2.0 CRDi	4	83	1991	11	D4EA	04/01→	UC33A
----------	---	----	------	----	------	--------	-------

**TUCSON**

2.0 CRDi	4	83	1991	11	D4EA	08/04→	UC33A
----------	---	----	------	----	------	--------	-------

2.0 CRDi All-wheel Drive	4	83	1991	11	D4EA	08/04→	UC33A
--------------------------	---	----	------	----	------	--------	-------

**ISUZU****TROOPER**

2.2 D 4x4	4	39	2238	11,5	C223	05/84→07/89	UC27A
-----------	---	----	------	------	------	-------------	-------

3.1 TD	4	84	3059	11	4 JG2 T	08/91→07/98	UC9A
--------	---	----	------	----	---------	-------------	------

**MIDI Van**

2.4 TD	4	56	2380	11	4FG1T	01/94→	UC9A
--------	---	----	------	----	-------	--------	------

**JAGUAR****S-TYPE (CCX)**

2.7 D	6	152	2720	11		06/04→	UY4A
-------	---	-----	------	----	--	--------	------

**X-TYPE (CF-1)**

2.0 D	4	96	1998	11,5	R4-X404	07/03→10/05	UC27A
-------	---	----	------	------	---------	-------------	-------

**JEEP****CHEROKEE**

2.5 CRD	4	105	2499	11,5	R 425 DOHC	09/01→	UC44A
---------	---	-----	------	------	------------	--------	-------

2.8 CRD	4	110	2776	11,5		11/02→	UC44A
---------	---	-----	------	------	--	--------	-------



## JEEP

### COMMANDER

3.0 CRD	6	160	2987	4,4		04/06→	UY8A
---------	---	-----	------	-----	--	--------	------

### COMPASS

2.0 CRD	4	103	1968	4,4		09/06→	UC03F
---------	---	-----	------	-----	--	--------	-------

2.0 CRD 4x4	4	103	1968	4,4		09/06→	UC03F
-------------	---	-----	------	-----	--	--------	-------

### GRAND CHEROKEE I

2.5 TD	4	85	2499	11	M51, M52	10/95→04/99	UC14A
--------	---	----	------	----	----------	-------------	-------

### GRAND CHEROKEE II

2.7 CRD 4x4	5	120	2685	11		10/01→	UC14A
-------------	---	-----	------	----	--	--------	-------

3.1 TD	5	103	3125	11		04/99→	UC14A
--------	---	-----	------	----	--	--------	-------

### GRAND CHEROKEE III

3.0 CRD	6	160	2987	4,4		06/05→	UY8A
---------	---	-----	------	-----	--	--------	------

### PATRIOT

2.0 TD	4	103	1968	4,4		01/08→	UC03F
--------	---	-----	------	-----	--	--------	-------

## KIA

### CARENS II

2.0 CRDi	4	83	1991	11		07/02→	UC33A
----------	---	----	------	----	--	--------	-------

### PREGIO

2.5 Tci D	4	69	2476	11	D4BH	09/02→	UZ4A
-----------	---	----	------	----	------	--------	------

3.0D	4	66	2987	11		01/98-→	UZ4A
------	---	----	------	----	--	---------	------

## LANCIA

### DEDRA

1.9 TDS	4	66	1929	11	160 D1.000, 835 A4.000, 835 A4.046	04/89→07/99	UX20A
---------	---	----	------	----	------------------------------------	-------------	-------

### DEDRA SW

1.9 TDS	4	66	1929	11	160 D1.000, 835 A4.000	07/94→07/99	UX20A
---------	---	----	------	----	------------------------	-------------	-------

### DELTA II

1.9 TD	4	66	1929	11	160 D1.000, 835 A4.000	10/94→08/99	UC4A
--------	---	----	------	----	------------------------	-------------	------

### KAPPA

2.4 T.DS	5	91	2387	11	838 A3.000, 838 A7.000	08/94→10/01	UC4A
----------	---	----	------	----	------------------------	-------------	------

2.4 JTD	5	100	2387	11	838 A8.000	06/98→10/01	UC19A
---------	---	-----	------	----	------------	-------------	-------

### KAPPA SW

2.4 T.DS	5	91	2387	11	838 A3.000, 838 A7.000	07/96→10/01	UC4A
----------	---	----	------	----	------------------------	-------------	------

2.4 JTD	5	100	2387	11	838 A8.000	06/98→10/01	UC19A
---------	---	-----	------	----	------------	-------------	-------

### LYBRA

1.9 JTD	4	77	1910	11	AR 32302	07/99→09/00	UC19A
---------	---	----	------	----	----------	-------------	-------

1.9 JTD	4	81	1910	11	AR 37101	09/00→05/01	UC19A
---------	---	----	------	----	----------	-------------	-------





<b>LANCIA</b>								
1.9 JTD	4	85	1910	11	937 A2.000	05/01→		<b>UC19A</b>
2.4 JTD	5	99	2387	11	839 A5.000, AR 32501	07/99→09/00		<b>UC19A</b>
2.4 JTD	5	103	2387	11	839 A6.000	09/00→05/02		<b>UC19A</b>
2.4 JTD	5	110	2387	11	841C.000	05/02→		<b>UC19A</b>
<b>LYBRA SW</b>								
1.9 JTD	4	77	1910	11	AR 32302	07/99→09/00		<b>UC19A</b>
1.9 JTD	4	81	1910	11	AR 37101	09/00→05/01		<b>UC19A</b>
1.9 JTD	4	85	1910	11	937 A2.000	05/01→		<b>UC19A</b>
2.4 JTD	5	99	2387	11	839 A5.000, AR 32501	10/99→09/00		<b>UC19A</b>
2.4 JTD	5	103	2387	11	839 A6.000	09/00→		<b>UC19A</b>
2.4 JTD	5	110	2387	11	841C.000	05/02→		<b>UC19A</b>
<b>MUSA</b>								
1.3 D Multijet	4	51	1248	11	188 A9.000	10/04→		<b>UY2A</b>
1.3 D Multijet	4	66	1248	11	188 A9.000	09/06→		<b>UY2A</b>
1.9 D Multijet	4	74	1910	11	188 B2.000	10/04→		<b>UC19A</b>
<b>PHEDRA</b>								
2.0 JTD	4	79	1997	11	RHM	07/03→		<b>UC12A</b>
2.0 JTD	4	80	1997	11	RHW(DW10ATED4)	09/02→		<b>UC12A</b>
2.2 JTD	4	94	2179	11	4HW(DW12ATED4)	09/02→		<b>UC12A</b>
<b>THESIS</b>								
1.9 JTD	4	59	1910	11		10/01→		<b>UC19A</b>
1.9 JTD	4	81	1910	11		10/01→		<b>UC19A</b>
2.4 JTD	5	110	2387	11	841C.000	07/02→		<b>UC19A</b>
2.4 JTD	5	129	2387	11	841 G.000	05/03→		<b>UY3A</b>
<b>YPSILON</b>								
1.3 D Multijet	4	51	1248	11	188 A9.000	10/03→		<b>UY2A</b>
1.3 D Multijet	4	66	1248	11	188 A9.000	09/06→		<b>UY2A</b>
<b>ZETA</b>								
2.0 JTD	4	80	1997	11	RHW	09/99→09/02		<b>UC12A</b>
2.1 TD	4	80	2088	11	P 8 C	05/96→09/99		<b>UX20A</b>

<b>LAND ROVER</b>								
<b>DEFENDER</b>								
2.5 90 TDI	4	83	2495	11,5	11 L, 16 L, 23 L	09/90→		<b>UC24A</b>
2.5 Td5 4WD	5	90	2495	11,5		06/98→		<b>UC24A</b>
<b>DISCOVERY I</b>								
2.5 TDI	4	83	2496	11,5	12 L, 21 L	09/89→06/94		<b>UC24A</b>



## LAND ROVER

### DISCOVERY II

2.5 TDI	4	83	2495	11,5	12 L, 17 L, 19 L, 21 L	08/96→	UC24A
2.5 TDI	4	90	2496	11,5	19 L, 22 L	10/95→	UC24A

### FREELANDER

2.0 DI	4	72	1994	11		02/98→11/00	UC8A
2.0 Td4	4	80	1951	11		11/01→	UC26A
2.0 Td4	4	82	1951	11		11/00→	UC26A

### RANGE ROVER III

3.0 TD 6	6	130	2926	11		03/02→	UC26A
----------	---	-----	------	----	--	--------	-------

## MAZDA

### 2

1.4 CD	4	50	1399	11	F6JA, F6JB	04/03→	UY1A
--------	---	----	------	----	------------	--------	------

### 3

1.6 DI Turbo	4	80	1560	11	Y601	06/04→	UY1A
--------------	---	----	------	----	------	--------	------

### 121 III

1.8 D	4	44	1753	11,5	RTJ, RTK	03/96→	UX19A
-------	---	----	------	------	----------	--------	-------

### 323 C IV

1.7 D	4	41	1720	11	PN54	08/89→07/94	UZ5A
-------	---	----	------	----	------	-------------	------

### 323 III (BF)

1.7 D	4	40	1720	11	PN27	04/86→05/89	UZ5A
-------	---	----	------	----	------	-------------	------

### 323 S IV (BG)

1.7 D	4	41	1720	11	PN46, PN54, PN62	08/89→07/94	UZ5A
-------	---	----	------	----	------------------	-------------	------

## MERCEDES-BENZ

### 190 (W201)

D 2.0	4	53	1997	11	OM 601.911	08/83→08/89	UX20A
D 2.5	5	66	2497	11	OM 602.911	04/85→08/93	UX20A
2.0 D 8V	4	53	1997	11,5	OM 601.911	02/89→08/93	UX13A
2.5 D 10V	5	66	2497	11,5	OM 602.911	02/89→08/93	UX13A
2.5 TD 10V	5	93	2497	11,5	OM 602.961	02/89→08/93	UX13A

### A-CLASS (W168)

A 160 CDI	4	44	1689	11,5	OM 668.941	07/98→02/01	UC18A
A 160 CDI	4	55	1689	11,5	OM 668.940	02/01→08/04	UC18A
A 170 CDI	4	66	1689	11,5	OM 668.940	07/98→02/01	UC18A
A 170 CDI	4	70	1689	11,5	OM 668.942	02/01→08/04	UC18A

### A-CLASS (W169)

A 160 CDI	4	60	1991	4,4	OM 640.942	09/04→	UY8A
A 180 CDI	4	80	1991	4,4	OM 640.940	09/04→	UY8A



		kW	cc	V			
<b>MERCEDES-BENZ</b>							
A 200 CDI	4	103	1991	4,4	OM 640.941	09/04→	UY8A
<b>B-CLASS (W245)</b>							
B 180 CDI	4	80	1991	4,4	OM 640.940	03/05→	UY8A
B 200 CDI	4	103	1991	4,4	OM 640.941	03/05→	UY8A
<b>C-CLASS (W202)</b>							
C 200 D 8V	4	55	1997	11,5	OM 601.913	03/93→05/00	UX13A
C 220 D	4	55	2155	11,5	OM 604.910 @ 021.055	07/96→05/00	UX16A
C 220 D	4	55	2155	11,5	OM 604.910 021.056@	07/96→05/00	UX17A
C 200 D	4	65	1997	11,5	OM 604.915	10/96→05/00	UX17A
C 220 D	4	70	2155	11,5	OM 604.910 @ 021.055	08/93→05/00	UX16A
C 220 D	4	70	2155	11,5	OM 604.910 021.056@	08/93→05/00	UX17A
C 200 CDI	4	75	2151	11,5	OM 611.960	03/98→05/00	UC17A
C 250 D	5	83	2497	11,5	OM 605.910 no immobilizer	05/93→05/00	UX16A
C 250 D	5	83	2497	11,5	OM 605.910 immobilizer	05/93→05/00	UX17A
C 220 CDI	4	92	2151	11,5	OM 611.960	09/97→05/00	UC17A
C 250 Turbo-D	5	110	2497	11,5	OM 605.960	10/95→05/00	UX17A
<b>C-CLASS (W203)</b>							
C 200 CDI	4	75	2148	11,5	OM 646.962	02/01→	UC17A
C 200 CDI	4	85	2148	11,5	OM 611.962	09/00→	UC17A
C 200 CDI	4	90	2148	11,5	OM 646.962	04/03→	UC17A
C 220 CDI	4	105	2148	11,5	OM 611.962	05/00→	UC17A
C 220 CDI	4	110	2148	11,5	OM 646.963	02/04→	UC17A
C 270 CDI	5	125	2685	11,5	OM 612.962	12/00→	UC17A
C 320 CDI	6	165	2987	4,4	OM 642.910	01/05→	UY8A
C 30 CDI AMG	5	170	2950	4,4	OM 612.990	01/03→	UC04F
<b>CLK (C209)</b>							
270 CDI	5	125	2685	11,5	OM 612.962, OM 612.967	10/02→	UC17A
320 CDI	6	165	2987	4,4	OM 642.910	01/05→	UY8A
<b>CLS (C219)</b>							
320 CDI	6	165	2987	4,4	OM 642.910	01/05→	UY8A
<b>E-CLASS (W124)</b>							
E 200 D	4	55	1997	11,5	OM 601.912	06/93→06/96	UX17A
E 250 D	5	83	2497	11,5	OM 605.911 no immobilizer	07/93→06/96	UX16A
E 250 D	5	83	2497	11,5	OM 605.911 immobilizer	07/93→06/96	UX17A
E 250 TD 10V	5	93	2497	11,5	OM 602.962	06/93→06/95	UX13A
E 300 D	6	100	2996	11,5	OM 606.910 no immobilizer	07/93→06/96	UX16A
E 300 D	6	100	2996	11,5	OM 606.910 immobilizer	07/93→06/96	UX17A
E 300 TD 12V	6	108	2996	11,5	OM 603.960	06/93→06/95	UX13A

**MERCEDES-BENZ**
**E-CLASS (W210)**

E 200 D	4	65	1997	11,5	OM 604.917	01/96→03/02	<b>UX17A</b>
E 200 CDI	4	75	2151	11,5	OM 611.961	06/98→03/02	<b>UC17A</b>
E 200 CDI	4	85	2148	11,5	OM 611.961	07/99→03/02	<b>UC17A</b>
E 220 D	4	55	2155	11,5	OM 604.912	05/96→03/02	<b>UX17A</b>
E 220 D	4	70	2155	11,5	OM 604.912 no immobilizer	06/95→07/99	<b>UX16A</b>
E 220 D	4	70	2155	11,5	OM 604.912 immobilizer	06/95→07/99	<b>UX17A</b>
E 220 CDI	4	92	2151	11,5	OM 611.961	06/98→07/99	<b>UC17A</b>
E 220 CDI	4	105	2148	11,5	OM 611.961	07/99→03/02	<b>UC17A</b>
E 250 D	5	83	2497	11,5	OM 605.912	06/95→07/99	<b>UX17A</b>
E 250 Turbo-D	5	110	2497	11,5	OM 605.962	06/97→07/99	<b>UX17A</b>
E 270 CDI	5	125	2685	11,5	OM 612.961	07/99→03/03	<b>UC17A</b>
E 290 Turbo-D	5	95	2874	11,5	OM 602.982	03/96→07/99	<b>UX23A</b>
E 300 D	6	100	2996	11,5	OM 606.912 no immobilizer	06/95→06/97	<b>UX16A</b>
E 300 D	6	100	2996	11,5	OM 606.912 immobilizer	06/95→06/97	<b>UX17A</b>
E 300 Turbo-D	6	130	2996	11,5	OM 606.962 no immobilizer	12/96→07/99	<b>UX16A</b>
E 300 Turbo-D	6	130	2996	11,5	OM 606.962 immobilizer	12/96→07/99	<b>UX17A</b>
E 320 CDI	6	145	3226	11,5	OM 613.961	07/99→03/03	<b>UC17A</b>

**E-CLASS (W211)**

E 200 CDI	4	75	2148	11,5	OM 646.951	07/02→	<b>UC17A</b>
E 200 CDI	4	90	2148	11,5	OM 646.951	07/02→	<b>UC17A</b>
E 220 CDI	4	110	2148	11,5	OM 646.961	03/02→	<b>UC17A</b>
E 270 CDI	5	130	2685	11,5	OM 647.961	03/02→	<b>UC17A</b>
E 280 CDI	6	130	3222	11,5	OM 648.961	05/04→	<b>UC17A</b>
E 280 CDI	6	140	2987	4,4	OM 642.920	03/05→	<b>UY8A</b>
E 280 CDI 4-matic	6	140	2987	4,4	OM 642.921	03/05→	<b>UY8A</b>
E 320 CDI	6	150	3222	11,5	OM 648.961	11/02→	<b>UC17A</b>
E 320 CDI	6	165	2987	4,4	OM 642.920	03/05→	<b>UY8A</b>
E 320 CDI 4-matic	6	165	2987	4,4	OM 642.910	03/05→	<b>UY8A</b>
E 400 CDI	8	191	3996	11,5	OM 628.961	02/03→	<b>UC17A</b>
E 420 CDI	8	231	3996	4,4	OM 629.910	01/06→	<b>UY8A</b>

**G CLASS (W460)**

250 GD 10V	5	62	2497	11,5	OM 602.930	02/89→08/92	<b>UX13A</b>
300 GD 12V	6	83	2996	11,5	OM 603.912	03/79→07/93	<b>UX13A</b>

**G CLASS (W461)**

250 GD 10V	5	68	2497	11,5	OM 602.939	02/90→	<b>UX13A</b>
290 GD/G 290 D	5	70	2874	11,5	OM 602.942	04/92→	<b>UX13A</b>
G 290 TD 10V	5	88	2874	11,5	OM 602.983	07/97→	<b>UX13A</b>



<b>MERCEDES-BENZ</b>							
<b>G-CLASS (W463)</b>							
G 270 CDI	5	115	2685	11,5	OM 612.966	10/01→	<b>UC17A</b>
G 300 TD	6	130	2996	11,5	OM 606.964	08/96→	<b>UX17A</b>
G 400 CDI	8	184	3996	11,5	OM 628.962	12/00→	<b>UC17A</b>
<b>GL-CLASS (X164)</b>							
GL 320 CDI	6	165	2987	4,4	OM 642.822	09/06→	<b>UY8A</b>
GL 420 CDI	8	225	3996	4,4	OM 629.912	09/06→	<b>UY8A</b>
<b>M-CLASS (W163)</b>							
ML 270 CDI	5	120	2685	11,5	OM 612.963	12/99→06/05	<b>UC17A</b>
ML 400 CDI	8	184	3996	11,5	OM 628.963	09/01→06/05	<b>UC17A</b>
<b>M-CLASS (W164)</b>							
ML 280 CDI	6	140	2987	4,4	OM 642.940	07/05→	<b>UY8A</b>
ML 320 CDI	6	165	2987	4,4	OM 642.940	07/05→	<b>UY8A</b>
<b>R-CLASS (W251)</b>							
R 280 CDI	6	140	2987	4,4	OM 642.940	05/06→	<b>UY8A</b>
R 320 CDI	6	165	2987	4,4	OM 642.950	01/06→	<b>UY8A</b>
<b>S-CLASS (W140)</b>							
S 300 Turbo-D	6	130	2996	11,5	OM 606.961	05/96→10/98	<b>UX17A</b>
S 350 Turbo-D	6	110	3449	11,5	OM 603.971	10/95→10/98	<b>UX17A</b>
S 350 TD 12V	6	110	3449	11,5	OM 603.971	01/93→09/95	<b>UX13A</b>
<b>S-CLASS (W220)</b>							
S 320 CDI	6	145	3222	11,5	OM 613.960	08/99→09/02	<b>UC17A</b>
S 320 CDI	6	150	3222	11,5	OM 648.960	09/02→08/05	<b>UC17A</b>
S 400 CDI	8	184	3996	11,5	OM 628.960	06/00→08/05	<b>UC17A</b>
S 400 CDI	8	191	3996	11,5	OM 628.960	06/03→08/05	<b>UC17A</b>
<b>VANEO</b>							
1.7 CDI	4	55	1689	11,5	OM 668.914	02/02→	<b>UC18A</b>
1.7 CDI	4	67	1689	11,5	OM 668.914	02/02→	<b>UC18A</b>
<b>V-CLASS</b>							
V 200 CDI	4	75	2151	11,5	OM 611.980	03/99→07/03	<b>UC17A</b>
V 220 CDI	4	90	2151	11,5	OM 611.980	03/99→07/03	<b>UC17A</b>
V 230 TD 8V	4	72	2299	11,5	OM 601.970	09/96→	<b>UX13A</b>
<b>VIANO</b>							
CDI 2.2	4	80	2148	11,5	OM 646.982	09/03→	<b>UC17A</b>
CDI 2.2	4	110	2148	11,5	OM 646.982	09/03→	<b>UC17A</b>
<b>SPRINTER 2-t (901, 902)</b>							
208 D 8V	4	58	2299	11,5	OM 601.943	02/95→04/00	<b>UX13A</b>
208 CDI	4	60	2148	11,5	OM 611.987	04/00→05/06	<b>UC17A</b>
210 D	5	75	2874	11,5	OM 602.980	01/97→04/00	<b>UX23A</b>

**MERCEDES-BENZ**

211 CDI	4	80	2148	11,5	OM 611.981	04/00→05/06	UC17A
212 D	5	90	2874	11	OM 602.980 ® 9849	02/95→04/00	UX20A
212 D	5	90	2874	11,5	OM 602.980 9850®	02/95→04/00	UX23A
213 CDI	4	95	2148	11,5	OM 611.981	04/00→05/06	UC17A
216 CDI	5	115	2685	11,5	OM 612.981	04/00→05/06	UC17A

**SPRINTER 3-t (903)**

308 D 8V	4	58	2299	11,5	OM 601.943	02/95→04/00	UX13A
308 CDI	4	60	2148	11,5	OM 611.987	04/00→05/06	UC17A
310 D 2.9	5	75	2874	11,5	OM 602.980	02/95→04/00	UX23A
311 CDI	4	80	2148	11,5	OM 611.981	04/00→05/06	UC17A
311 CDI 4x4	4	80	2148	11,5	OM 611.981	08/02→05/06	UC17A
312 D 2.9	5	90	2874	11	OM 602.980	02/95→04/00	UX20A
312 D 2.9	5	90	2874	11	OM 602.980 ®9849	02/95→04/00	UX20A
312 D 2.9	5	90	2874	11,5	OM 602.980 9850®	02/95→04/00	UX23A
312 D 2.9 4x4	5	90	2874	11	OM 602.980	05/97→08/02	UX20A
312 D 2.9 4x4	5	90	2874	11,5	OM 602.980	05/97→08/02	UX23A
313 CDI	4	95	2148	11,5	OM 611.981	04/00→05/06	UC17A
313 CDI 4x4	4	95	2148	11,5	OM 611.981	08/02→05/06	UC17A
316 CDI	5	115	2685	11,5	OM 612.981	04/00→05/06	UC17A
316 CDI 4x4	5	115	2685	11,5	OM 612.981	08/02→05/06	UC17A
310 D 4x4	5	75	2874	11,5	OM 602.980	05/97→08/02	UX23A

**SPRINTER 4-t (904)**

408 CDI	4	60	2148	11,5	OM 611.987	04/00→05/06	UC17A
410 D	5	75	2874	11,5	OM 602.980	02/96→05/06	UX23A
410 D 4x4	5	75	2874	11,5	OM 602.980	05/97→05/06	UX23A
411 CDI	4	80	2148	11,5	OM 611.981	04/00→05/06	UC17A
411 CDI 4x4	4	80	2148	11,5	OM 611.981	04/00→05/06	UC17A
412 D	5	85	2874	11,5	OM 602.980	02/96→05/06	UX23A
412 D 4x4	5	85	2874	11,5	OM 602.980	05/97→05/06	UX23A
412 D	5	90	2874	11	OM 602.980	02/96→05/06	UX20A
412 D	5	90	2874	11,5	OM 602.980	02/96→05/06	UX23A
412 D 4x4	5	90	2874	11	OM 602.980	05/97→05/06	UX20A
412 D 4x4	5	90	2874	11,5	OM 602.980	05/97→05/06	UX23A
413 CDI	4	95	2148	11,5	OM 611.981	04/00→05/06	UC17A
413 CDI 4x4	4	95	2148	11,5	OM 611.981	04/00→05/06	UC17A
416 CDI	5	115	2685	11,5	OM 612.981	04/00→05/06	UC17A
416 CDI 4x4	5	115	2685	11,5	OM 612.981	04/00→05/06	UC17A

**kW**
**cc**
**V**

**MAGNETI MARELLI**
**MERCEDES-BENZ**
**T1 Series**

208 D 2.3 8V	4	60	2299	11,5	OM 601.940	10/88→02/96	<b>UX13A</b>
210 D 2.8 10V	5	70	2874	11,5	OM 602.940	11/88→02/96	<b>UX13A</b>
308 D 2.3 8V	4	60	2299	11,5	OM 601.940	06/89→02.96	<b>UX13A</b>
308 D 2.3 8V	4	58	2299	11,5	OM 601.940	05/90→02/96	<b>UX13A</b>
310 D 2.9 10V	5	70	2874	11,5	OM 602.940	06/89→02.96	<b>UX13A</b>

**VITO (638)**

108 D 2.3 8V	4	58	2299	11,5	OM 601.942	02/96→	<b>UX13A</b>
108 CDI 2.2	4	60	2151	11,5	OM 611A (60 KW CDI)	03/99→07/03	<b>UC17A</b>
110 CDI 2.2	4	75	2151	11,5	OM 611LA (75 KW CDI)	03/99→07/03	<b>UC17A</b>
112 CDI 2.2	4	90	2151	11,5	OM 611.980	03/99→07/03	<b>UC17A</b>

**VITO (W639)**

109 CDI 2.2	4	65	2148	11,5	OM 646.983	09/03→	<b>UC17A</b>
111 CDI 2.2	4	80	2148	11,5	OM 646.982	09/03→	<b>UC17A</b>
115 CDI 2.2	4	110	2148	11,5	OM 646.982	09/03→	<b>UC17A</b>

**MG**
**ZR**

Turbodiesel	4	74	1994	11		06/01→	<b>UC8A</b>
-------------	---	----	------	----	--	--------	-------------

**ZS**

2.0 TD	4	74	1994	11		01/04→	<b>UC8A</b>
--------	---	----	------	----	--	--------	-------------

**ZT**

2.0 CDTi	4	85	1951	11	204D2	06/02→09/03	<b>UC26A</b>
2.0 CDTi	4	96	1951	11	204D2	11/02→	<b>UC26A</b>

**MINI**
**ONE D**

1.4 D	4	55	1364	11	1ND-TV (Toyota)	06/03→	<b>UC32A</b>
1.4 D	4	65	1364	11	1ND-TV (Toyota)	06/03→	<b>UC32A</b>

**COOPER D**

1.6 D	4	80	1560	11	9HZ (DV6TED4)	03/07→	<b>UY5A</b>
-------	---	----	------	----	---------------	--------	-------------

**COOPER D Clubman**

1.6 D	4	80	1560	11	9HZ (DV6TED4)	10/07→	<b>UY5A</b>
-------	---	----	------	----	---------------	--------	-------------

**MINI**
**CARISMA**

1.9 TD 8V	4	66	1870	11	F8QT	10/96→09/00	<b>UX18A</b>
1.9 DI-D	4	75	1870	11	F9Q1	09/00→06/06	<b>UC31A</b>
1.9 DI-D	4	85	1870	11	F9Q2	09/00→06/06	<b>UC31A</b>



<b>mitsubishi</b>								
<b>GALLOPER</b>								
2.5 TD	4	65	2476	11			02/99→	<b>UZ4A</b>
2.5 TD intercooler	4	73	2476	11	D4BH		02/99→	<b>UZ4A</b>
<b>OUTLANDER</b>								
2.0 DI-D	4	103	1968	4,4	BSY		02/07→	<b>UC03F</b>
<b>SPACE STAR</b>								
1.9 DI-D	4	75	1870	11	F9Q1		02/01→	<b>UC31A</b>
1.9 DI-D	4	85	1870	11	F9Q2		10/02→	<b>UC31A</b>
<b>L 200</b>								
2.5 TD 4WD	4	85	2477	11	4 D 56 T		09/01→	<b>UZ4A</b>
2.5 TD 4WD	4	98	2477	11			08/03→	<b>UZ4A</b>
<b>L 400</b>								
2500 TD 4x4	4	64	2477	11	4 D 56 T		09/96→	<b>UZ4A</b>

<b>NISSAN</b>								
<b>ALMERA I</b>								
2.0 D	4	55	1974	11	CD20		11/95→07/00	<b>UZ3A</b>
<b>ALMERA II</b>								
1.5 dCi	4	60	1461	11	K9K 722		01/03→	<b>UC31A</b>
2.2 Di	4	81	2184	11	YD22DDT		03/00→	<b>UX24A</b>
2.2 dCi	4	82	2184	11	YD22DDT		09/03→	<b>UX24A</b>
2.2 dCi	4	100	2184	11	YD22DDTi		09/03→	<b>UX24A</b>
<b>ALMERA TINO</b>								
2.2 dCi	4	82	2184	11	YD22DDT		09/03→	<b>UX24A</b>
2.2 Di	4	84	2184	11	YD22DDTi		08/00→	<b>UX24A</b>
2.2 dCi	4	100	2184	11	YD22DDTi		09/03→	<b>UX24A</b>
<b>MICRA</b>								
1.5 D	4	42	1527	11	TUD5 (VJX) Peugeot		02/98→02/03	<b>UC15A</b>
1.5 dCi	4	48	1461	11	K9K 704 Renault		01/03→	<b>UC31A</b>
1.5 dCi	4	50	1461	11			01/03→	<b>UC31A</b>
1.5 dCi	4	60	1461	11	K9K 722 Renault		09/03→	<b>UC31A</b>
1.5 dCi	4	63	1461	11			01/03→	<b>UC31A</b>
<b>NOTE</b>								
1.5 dCi	4	50	1461	11	K9K 700		03/06→	<b>UC31A</b>
1.5 dCi	4	63	1461	11			03/06→	<b>UC31A</b>
<b>PATHFINDER</b>								
2.7 D 8V	4	59		11			02/93→	<b>UC23A</b>
2.7 D 8V	4	73		11			01/93→	<b>UC23A</b>
2.7 TD 4WD	4	96	2664	11	TD27ETi		09/97→	<b>UC23A</b>





NISSAN								
PATROL								
4.2 D 12V	6	85	4169	11	TD42		11/88→06/97	UC23A
2.7 TD 8V	4	73		11	TD27		02/93→	UC23A
PRIMERA								
2.0 D	4	55	1974	11	CD20		07/90→01/96	UZ3A
2.0 TD	4	66	1974	11	CD20T		09/96→07/02	UZ3A
1.9 dCi	4	85	1870	11			08/02→	UC31A
1.9 dCi	4	88	1870	11			04/03→	UC31A
2.2 Di	4	93	2184	11	YD22DDT		03/02→	UX24A
2.2 dCi	4	102	2184	11	YD22DDT		04/03→	UX24A
QASHQAI								
1.5 dCi	4	78	1461	11			02/07→	UC31A
SERENA								
2.3 D	4	55	2283	11	CD23		01/95→	UC36A
SUNNY III								
2.0 D	4	55	1974	11	CD20		10/90→03/00	UZ3A
TERRANO								
2.7 TD 4WD	4	73	2664	11	TD27T		02/89→02/96	UC36A
2.7 TD 4WD	4	74	2664	11	TD27T		02/93→01/02	UC36A
2.7 TDi 4WD	4	92	2664	11	TD27Ti		05/96→	UC36A
TIIDA								
1.5 dCi	4	78	1461	11			09/07→	UC31A
X-TRAIL								
2.2 Di 4x4	4	84	2184	11	YD22ETi		07/01→	UX24A
2.2 dCi 4x4	4	100	2184	11	YD22DDTi		12/03→	UX24A
INTERSTAR								
dCi 80	4	60	1870	11	F9Q 772		07/02→	UC31A
dCi 90	4	66	2188	11	G9T 722		07/02→	UC29A
KING CAB								
2.5 D 8V	4	61		11	TD25		01/93→	UC23A
2.5 TD 8V	4	61		11	TD25		02/98→	UC23A
2.5 TDi	4			11			05/98→	UC23A
KUBISTAR								
1.5 dCi	4	42	1461	11			08/03→	UC31A
1.5 dCi	4	45	1461	11			08/05→	UC31A
1.5 dCi	4	48	1461	11	K9K 704		08/03→	UC31A
1.5 dCi 70	4	50	1461	11			04/06→	UC31A
1.5 dCi	4	60	1461	11	K9K 722		08/03→	UC31A
1.5 dCi 85	4	62	1461	11			04/06→	UC31A

**NISSAN**
**PICK UP**

2.5 D 8V	4	59	2494	11	TD25	09/94→02/98	<b>UC23A</b>
2.5 D 8V	4	61	2494	11	TD25	03/96→	<b>UC23A</b>
2.5 Di 4WD	4	98	2488	11	YD25DDTi	03/02→	<b>UX24A</b>

**PRIMASTAR**

dCi 80	4	60	1870	11	F9Q 762	03/01→	<b>UC31A</b>
dCi 100	4	74	1870	11	F9Q 760	03/01→	<b>UC31A</b>
dCi 140	4	99	2463	11	G9U 730	07/03→	<b>UC29A</b>

**VANETTE CARGO**

2.3 D	4	55	2283	11	LD23	01/95→	<b>UC36A</b>
-------	---	----	------	----	------	--------	--------------

**OPEL**
**AGILA**

1.3 CDTI	4	51	1248	11	Z 13 DT	08/03→	<b>UY2A</b>
----------	---	----	------	----	---------	--------	-------------

**ASTRA F**

1.7 D	4	42	1700	11	17 D	12/91→09/92	<b>UX20A</b>
1.7 D	4	44	1700	11	17 DR	07/92→09/98	<b>UX20A</b>
1.7 TD	4	50	1700	11	X 17 DTL	11/94→09/98	<b>UX20A</b>
1.7 TDS	4	60	1686	11	17 DT (TC4EE1), X 17 DT (TC4EE1) ® 956632	03/92→09/98	<b>UC9A</b>
1.7 TDS	4	60	1686	11	17 DT (TC4EE1), X 17 DT (TC4EE1) 956633®	03/92→09/98	<b>UZ1A</b>

**ASTRA G**

1.7 TD	4	50	1700	11	X 17 DTL	09/98→04/05	<b>UX20A</b>
1.7 DTI 16V	4	55	1686	11	Y 17 DT	02/00→01/05	<b>UZ2A</b>
1.7 CDTI	4	59	1686	11	Z 17 DTL	04/03→01/05	<b>UZ2A</b>
2.0 DI	4	60	1995	11	X 20 DTL, Y 20 DTL	02/98→01/05	<b>UC16A</b>
2.0 DTI 16V	4	74	1995	11	X 20 DTH, Y 20 DTH	08/99→01/05	<b>UC16A</b>
2.2 DTI	4	92	2172	11	Y 22 DTR	09/02→10/05	<b>UC28A</b>

**ASTRA H**

1.3 CDTI	4	66	1248	11	Z 13 DTH	04/05→	<b>UY2A</b>
1.7 CDTI	4	59	1686	11	Z 17 DTL	03/04→	<b>UZ2A</b>
1.7 CDTI	4	74	1686	11	Z 17 DTH	03/04→	<b>UZ2A</b>
1.9 CDTI	4	74	1910	11	Z 19 DT	09/05→	<b>UC19A</b>
1.9 CDTI	4	88	1910	11	Z 19 DT	06/04→	<b>UY3A</b>
1.9 CDTI 16V	4	88	1910	11	Z 19 DTH, Z 19 DTJ	04/04→	<b>UY3A</b>
1.9 CDTI	4	110	1910	11	Z 19 DTH	09/04→	<b>UY3A</b>



<b>OPEL</b>							
<b>CORSA B</b>							
1.5 D	4	37	1488	11	15 D (4EC1)	03/93→09/00	<b>UZ1A</b>
1.5 TD	4	49	1488	11	15 DT (T4EC1), X 15 DT (T4EC1)	03/93→09/00	<b>UZ1A</b>
1.7 D	4	44	1686	11	17 D (4EE1), X 17 D (4EE1)	02/96→09/00	<b>UZ1A</b>
<b>CORSA C</b>							
1.3 CDTI	4	51	1248	11	Z 13 DT	06/03→	<b>UY2A</b>
1.7 DI	4	48	1686	11	Y 17 DTL	09/00→	<b>UZ2A</b>
1.7 DTI	0	55	1686	11	Y 17 DT	09/00→	<b>UZ2A</b>
1.7 CDTI	4	74	1686	11	Z 17 DTH	06/03→	<b>UZ2A</b>
<b>CORSA D</b>							
1.3 CDTI	4	55	1248	11	Z 13 DTJ	07/06→	<b>UY2A</b>
1.3 CDTI	4	66	1248	11	Z 13 DTH	07/06→	<b>UY2A</b>
1.7 CDTI	4	92	1686	11	Z 17 DTR	07/06→	<b>UZ2A</b>
<b>FRONTERA</b>							
2.3 TD	4	74	2260	11	23 DTR	03/92→10/98	<b>UX20A</b>
2.2 DTI	4	85	2171	11	X 22 DTH	10/98→07/00	<b>UC16A</b>
2.2 DTI	4	85	2171	11	Y 22 DTH	08/00→09/02	<b>UC28A</b>
2.2 DTI	4	88	2171	11	Y 22 DTH	09/02→	<b>UC28A</b>
2.5 TDS	4	85	2499	11	25TDS (VM41B)	09/96→10/98	<b>UC14A</b>
<b>KADETT E</b>							
1.7 D	4	42	1700	11	17 D	01/89→07/94	<b>UX20A</b>
1.7 TD 8V	4	60		11,5	TC4EE1 OHC Isuzu (mot 817253@)	02/90→08/91	<b>UX13A</b>
<b>MERIVA</b>							
1.3 CDTI	4	55	1248	11	Z 13 DTJ	09/03→	<b>UY2A</b>
1.7 DTI	4	55	1686	11	Y 17 DT	09/03→	<b>UZ2A</b>
1.7 CDTI	4	74	1686	11	Z 17 DTH	09/03→	<b>UZ2A</b>
<b>MONTEREY</b>							
3.1 TD (UBS69_)	4	84	3059	11	4 JG2TC	09/91→07/98	<b>UC9A</b>
<b>OMEGA</b>							
2.0 DTI 16V	4	74	1995	11	X 20 DTH	09/97→09/00	<b>UC28A</b>
2.2 DTI 16V	4	88	2171	11	Y 22 DTH	09/00→07/03	<b>UC28A</b>
2.3 D	4	54	2260	11	23 YD	09/86→03/94	<b>UX20A</b>
2.3 TD Interc.	4	74	2260	11	23 DTR	08/88→03/94	<b>UX20A</b>
2.5 TD	6	96	2497	11	25 DT, X 25 DT, X 25 TD	04/94→07/03	<b>UX20A</b>
2.5 DTI	6	110	2497	11	Y 25 DT	09/01→07/03	<b>UC26A</b>



## OPEL

### SIGNUM

1.9 CDTI	4	88	1910	11	Z 19 DT	04/04→	UY3A
1.9 CDTI	4	110	1910	11	Z 19 DTH	04/04→	UY3A
2.0 DTI	4	74	1994	11	Y 20 DTH	05/03→	UC28A
2.2 DTI	4	92	2171	11	Y 22 DTR	05/03→	UC28A

### SINTRA

2.2 DTI	4	85	2171	11	X 22 DTH	07/97→04/99	UC16A
---------	---	----	------	----	----------	-------------	-------

### TIGRA TwinTop

1.3 CDTI	4	51	1248	11	Z 13 DT	06/04→	UY2A
----------	---	----	------	----	---------	--------	------

### VECTRA A

1.7 D	4	42	1700	11	17 D	09/88→09/92	UX20A
1.7 D	4	44	1700	11	17 DR	07/92→11/95	UX20A
1.7 TD	4	60	1686	11	17 DT (TC4EE1), X 17 DT (TC4EE1)	03/90→11/95	UZ1A

### VECTRA B

1.7 TD	4	60	1686	11	X 17 DT (TC4EE1)	10/95→12/98	UZ1A
2.0 DI 16V	4	60	1995	11	X 20 DTL	11/96→04/02	UC16A
2.0 DTI 16V	4	74	1995	11	X 20 DTH	03/98→06/00	UC16A
2.0 DTI 16V	4	74	1995	11	Y 20 DTH	07/00→04/02	UC28A
2.2 DTI 16V	4	92	2172	11	Y 22 DTR	09/00→07/03	UC28A

### VECTRA C

1.9 CDTI	4	74	1910	11	Z 19 DT	10/05→	UC19A
1.9 CDTI	4	88	1910	11	Z 19 DT	04/04→	UY3A
1.9 CDTI	4	110	1910	11	Z 19 DTH	04/04→	UY3A
2.0 DTI 16V	4	74	1995	11	Y 20 DTH	04/02→	UC28A
2.2 DTI 16V	4	92	2172	11	Y 22 DTR	04/02→	UC28A

### ZAFIRA

1.9 CDTI	4	74	1910	11	Z 19 DT	07/05→	UC19A
1.9 CDTI	4	88	1910	11	Z 19 DT	07/05→	UY3A
1.9 CDTI	4	110	1910	11	Z 19 DTH	07/05→	UY3A
2.0 DI 16V	4	60	1995	11	X 20 DTL	10/99→06/05	UC16A
2.0 DTI 16V	4	74	1995	11	Y 20 DTH	09/00→06/05	UC16A
2.2 DTI 16V	4	92	2172	11	Y 22 DTR	01/02→06/05	UC28A

### ARENA

1.9 D	4	44	1870	11	F8Q 600, F8Q 606	03/98→08/01	UC21A
2.5 D	4	55	2499	11	S8U 758, S8U 780, S8U 782	03/98→08/01	UX20A

**OPEL**
**CAMPO**

2.2 D 4x4	4	39	2238	11	C223	08/91→09/96	<b>UC10A</b>
2.5 D	4	56	2499	11	4 JA1	08/91→06/94	<b>UX20A</b>
2.5 D 4x4	4	56	2499	11	4 JA1	08/91→06/94	<b>UX20A</b>
3.1 TD	4	80	3059	11	4 JG2T	12/92→	<b>UC9A</b>
3.1 TD 4x4	4	80	3059	11	4 JG2T	12/92→	<b>UC9A</b>

**COMBO**

1.3 CDTI 16V	4	51	1248	11	Y 13 DT, Z 13 DT	08/05→	<b>UY2A</b>
1.7 D	4	44	1686	11	17 D (4EE1), X 17 D (4EE1)	07/94→10/01	<b>UZ1A</b>
1.7 DI 16V	4	48	1686	11	Y 17 DTL	10/01→	<b>UX20A</b>
1.7 DTI 16V	4	55	1686	11	Y 17 DT	10/01→	<b>UZ2A</b>

**MOVANO**

1.9 DTI	4	59	1870	11	F9Q 770	09/00→10/01	<b>UC31A</b>
1.9 DTI	4	60	1870	11	F9Q 774	10/01→	<b>UC31A</b>
2.2 DTI	4	66	2188	11	G9T 720	09/00→	<b>UC29A</b>
2.5 D	4	59	2499	11,5	S8U 770	01/99→09/00	<b>UX11A</b>
2.5 DTI	4	84	2463	11	G9U 720, G9U 754	10/01→	<b>UC29A</b>

**VIVARO**

1.9 DI	4	60	1870	11	F9Q 762	08/01→	<b>UC31A</b>
1.9 DTI	4	74	1870	11	F9Q 760	08/01→	<b>UC31A</b>
2.5 DTI	4	99	2463	11	G9U 730	05/03→	<b>UC29A</b>

**PEUGEOT**
**106**

1.4 D	4	37	1361	11,5	K9Y (TUD3Y)	09/92→04/96	<b>UX11A</b>
1.5 D	4	40	1527	11	VJY (TUD5)	06/94→	<b>UC15A</b>
1.5 D	4	43	1527	11		06/94→04/96	<b>UC15A</b>
1.5 D	4	42	1527	11	VJX (TUD5)	10/00→	<b>UC15A</b>

**107**

1.4 HDi	4	40	1398	11		06/05→	<b>UY1A</b>
---------	---	----	------	----	--	--------	-------------

**205**

1.7 Diesel	4	44	1769	11	161A (XUD7)	07/87→	<b>UX20A</b>
1.9 Diesel	4	47	1905	11	DJZ (XUD9Y)	10/87→09/98	<b>UX20A</b>
1.7 TD	4	57	1769	11	A8B (XUD7TE)	01/90→09/98	<b>UX20A</b>

**206**

1.4 Hdi	4	50	1398	11	8HX (DV4TD), 8HZ (DV4TD)	09/01→	<b>UY1A</b>
1.6 HDi 110	4	80	1560	11	9HY (DV6TED4), 9HZ (DV6TED4)	05/04→	<b>UY1A</b>
1.9 D	4	51	1868	11	WJZ (DW8)	09/98→11/01	<b>UC15A</b>



### PEUGEOT

2.0 HDI 90	4	66	1997	11	RHY (DW10TD)	12/99→	UC12A
------------	---	----	------	----	--------------	--------	-------

### 207

1.4 HDi	4	50	1398	11		02/06→	UY5A
1.6 HDi	4	66	1560	11	9HX (DV6ATED4)	02/06→	UY5A
1.6 HDi	4	80	1560	11	9HY (DV6TED4), 9HZ (DV6TED4)	02/06→	UY5A

### 306

1.8 D	4	43	1769	11	A9A (XUD7)	05/93→08/98	UX20A
1.8 D	4	43	1769	11	A9A (XUD7)	09/98→05/01	UX20A
1.9 SLD	4	47	1905	11	DJZ (XUD9Y)	06/94→05/01	UX20A
1.9 D	4	50	1905	11	DJY (XUD9A)	03/97→08/98	UX20A
1.9 D	4	50	1905	11	DJY (XUD9A)	09/98→04/02	UX20A
1.9 D	4	51	1868	11	WJY (DW8B), WJZ (DW8)	09/98→04/02	UC15A
1.9 D	4	55	1905	11	DHW (XUD9BSD)	03/98→04/02	UX20A
1.9 TD	4	66	1905	11	DHY (XUD9TE)	09/98→04/02	UX20A
1.9 TD	4	66	1905	11	DHY (XUD9TE)	02/97→08/98	UX20A
2.0 HDI 90	4	66	1997	11	RHY (DW10TD)	06/99→04/02	UC12A

### 307

1.4 HDi	4	50	1398	11	8HX (DV4TD), 8HZ (DV4TD)	10/01→	UY1A
1.6 HDi	4	66	1560	11	9HX (DV6ATED4)	04/05→	UY5A
1.6 HDi 110	4	80	1560	11	9HY (DV6TED4)	02/04→	UY1A
2.0 HDi 90	4	66	1997	11	RHY (DW10TD)	08/00→	UC12A
2.0 HDi 110	4	79	1997	11	RHS (DW10ATED)	08/00→	UC12A
2.0 HDi 135	4	100	1997	11	RHR (DW10BTED4)	10/03→	UC12A

### 405

1.9 D	4	47	1905	11	DJZ (XUD9Y)	08/92→10/95	UX20A
1.9 D	4	50	1905	11	DJY (XUD9A)	06/94→10/95	UX20A
1.9 TD	4	66	1905	11	DHY (XUD9TE)	08/92→10/95	UX20A

### 406

1.9 D	4	55	1905	11	DHW (XUD9SD)	10/96→08/98	UX20A
1.9 D	4	55	1905	11	DHW (XUD9SD)	09/98→10/04	UX20A
1.9 TD	4	66	1905	11	DHX (XUD9TE)	01/96→08/98	UX20A
1.9 TD	4	66	1905	11	DHX (XUD9TE)	09/98→10/04	UX20A
1.9 TD	4	68	1905	11	DHY (XUD9TE)	01/96→08/98	UX20A
1.9 TD	4	68	1905	11	DHY (XUD9TE)	09/98→05/04	UX20A
2.0 HDI 90	4	66	1997	11	RHY (DW10TD)	02/99→10/04	UC12A
2.0 HDi 110	4	79	1997	11	RHS (DW10ATED), RHZ (DW10ATED)	08/01→10/04	UC12A
2.0 HDi 110	4	80	1997	11	RHZ (DW10ATED)	06/98→04/04	UC12A



PEUGEOT								
2.1 TD 12V	4	80	2088	11	P8C (XUD11BTE)	01/96→08/98	UX20A	
2.1 TD 12V	4	80	2088	11	P8C (XUD11BTE)	09/98→10/04	UX20A	
2.2 HDi	4	98	2179	11	4HX (DW12TED4/FAP)	03/00→12/04	UC12A	
407								
1.6 HDi 110	4	80	1560	11	9HY (DV6TED4)	05/04→	UY1A	
2.0 HDi 135	4	100	1997	11	RHR (DW10BTED4)	05/04→	UC12A	
605								
2.1 D	4	60	2138	11	P9A (XUD11A)	06/89→07/95	UX20A	
2.1 TD 12V	4	80	2088	11	P8C (XUD11BTE) CEE95L3 09/98®	09/98→09/99	UX20A	
2.1 TD 12V	4	80	2088	11	P8C (XUD11BTE) CEE95L3 ®08/98	08/94→08/98	UX20A	
2.1 Turbo Diesel	4	80	2088	11	PHZ (XUD11ATE)	06/89→09/99	UX20A	
2.5 Turbo Diesel	4	95	2446	11	THY (DK5ATE)	07/94→09/99	UX20A	
607								
2.0 HDI	4	80	1997	11	RHZ (DW10ATED)	05/00→	UC12A	
2.0 HDI	4	100	1997	11	RHR (DW10BTED4)	09/05→	UC41A	
2.2 HDI	4	98	2179	11	4HX (DW12TED4/FAP)	02/00→	UC12A	
2.7 HDi 24V	6	150	2721	11	DT17TED4	12/04→	UY4A	
806								
1.9 TD	4	66	1905	11	DHX (XUD9TE)	07/95→08/02	UX20A	
1.9 TD	4	68	1905	11	DHY (XUD9TE)	05/97→08/02	UX20A	
2.0 HDI	4	80	1997	11	RHZ (DW10ATED)	08/99→08/02	UC12A	
2.0 HDI 16V	4	80	1997	11	RHW (DW10ATED4)	08/99→08/02	UC12A	
2.1 td 12V	4	80	2088	11	P8C (XUD11BTE)	06/96→08/98	UX20A	
807								
2.0 HDi	4	79	1997	11	RHK (DW10UTED4), RHM (DW10ATED4), RHT (DW10ATED4), RHW (DW10ATED4)	06/02→	UC12A	
2.2 HDi	4	94	2179	11	4HX (DW12TED4/FAP)	06/02→	UC12A	
1007								
1.4 HDi	4	50	1398	11	8HX (DV4TD), 8HZ (DV4TD)	04/05→	UY1A	
BOXER								
1.9 D	4	50	1905	11	DJY (XUD9A)	07/99→04/02	UX20A	
1.9 D	4	51	1905	11	D8C (XUD9AU)	03/94→06/95	UX20A	
1.9 D	4	51	1905	11	D8C (XUD9AU)	07/95→08/98	UX20A	
1.9 D	4	51	1905	11	D8C (XUD9AU)	09/98→04/02	UX20A	
1.9 TD	4	66	1905	11	DHY (XUD9TE)	08/94→08/98	UX20A	
1.9 TD	4	66	1905	11	DHY (XUD9TE)	09/98→04/02	UX20A	



### PEUGEOT

1.9 TD	4	68	1905	11	D8C (XUD9UTF)	03/94→08/98	UX20A
1.9 TD	4	68	1905	11	D8C (XUD9UTF)	09/98→04/02	UX20A
1.9 TD 4x4	4	68	1905	11	D8C (XUD9UTF)	07/96→08/98	UX20A
1.9 TD 4x4	4	68	1905	11	D8C (XUD9UTF)	09/98→04/02	UX20A
2.0 HDI	4	62	1997	11		08/01→04/02	UC12A
2.0 HDi	4	62	1997	11	RHV (DW10UTD)	04/02→	UC12A
2.2 HDi	4	74	2179	11	4HY (DW12UTED)	04/02→	UC12A
2.5 D	4	63	2446	11	T9A (DJ5)	03/94→04/02	UX20A
2.5 D 4x4	4	63	2446	11	T9A (DJ5)	07/99→04/02	UX20A
2.5 TD	4	76	2446	11	T8A (DJ5T)	03/94→04/02	UX20A
2.5 TD 4x4	4	76	2446	11	T8A (DJ5T)	07/96→04/02	UX20A
2.5 TDI	4	79	2446	11	THX (DJ5TED)	01/97→04/02	UC40A
2.5 TDI 4x4	4	79	2446	11	THX (DJ5TED)	01/97→04/02	UC40A
2.8 HDI	4	94	2798	11	8140.43S	11/00→04/02	UC37A
2.8 HDi	4	94	2798	11	8140.43S	04/02→	UC37A
2.8 HDi 4x4	4	94	2798	11	8140.43S	04/02→	UC37A
2.8 HDi	4	107	2798	11		04/04→	UC37A

### EXPERT

1.9 D	4	51	1905	11	D9B (XUD9AU)	02/96→	UX20A
1.9 TD	4	66	1905	11	DHX (XUD9TE)	02/96→	UX20A
1.9 TD	4	68	1905	11	D8B (XUD9TE)	02/96→	UX20A
2.0 HDI	4	80	1997	11	RHZ (DW10ATED)	07/00→	UC12A
2.0 HDI	4	80	1997	11	RHW (DW10ATED4)	07/00→	UC12A

### J5

1.9 D	4	51	1905	11	D9B (XUD9A)	10/90→	UX20A
2.5 D 4x4	4	54	2500	11	CRD93 (U25/661)	10/90→	UX20A
2.5 TD	4	70	2500	11	CRD93LS (U25/673)	10/90→	UX20A
2.5 TD 4x4	4	70	2500	11	CRD93LS (U25/673)	10/90→	UX20A
2.5 D	4	54	2498	11	CRD93 (U25/661)	09/81→09/90	UX20A

### PARTNER

1.8 D	4	43	1769	11	A9A (XUD7)	06/96→	UX20A
1.9 D	4	51	1868	11	WJY (DW8B), WJZ (DW8)	06/96→	UC15A
1.9 D 4x4	4	51	1868	11	WJY (DW8B)	04/04→	UC15A
1.9 D	4	51	1905	11	DJY (XUD9A)	06/96→	UX20A
2.0 HDi	4	66	1997	11	RHY (DW10TD)	04/00→	UC12A
2.0 HDi 4x4	4	66	1997	11	RHY (DW10TD)	04/04→	UC12A



**RENAULT**
**19**

1.9 D	4	47	1870	11	F8Q 706, F8Q 742	03/91→04/92	<b>UX14A</b>
1.9 D	4	47	1870	11	F8Q 742	04/92→12/95	<b>UX14A</b>
1.9 D	4	47	1870	11	F8Q 742	04/92→12/95	<b>UX14A</b>
1.9 D	4	48	1870	11	F8Q 706, F8Q 742	03/91→12/92	<b>UX14A</b>
1.9 D	4	48	1870	11	F8Q 706, F8Q 742	03/92→12/95	<b>UX14A</b>
1.9 dT 8V	4	66	1870	11	F8Q 744	04/92→12/95	<b>UX18A</b>
1.9 TD 8V	4	68	1870	11		09/90→04/92	<b>UX18A</b>

**21**

1.9 D	4	47	1870	11	F8Q 710	03/91→08/94	<b>UX14A</b>
2.1 D 4x4	4	48	2068	11	J8S 704	10/88→05/92	<b>UX20A</b>
2.1 D	4	49	2068	11	J8S 704	06/86→08/94	<b>UX20A</b>
2.1 D	4	51	2068	11	J8S 784	02/92→09/95	<b>UX20A</b>
2.1 D	4	53	2068	11	J8S 600, J8S 740	05/89→06/94	<b>UX20A</b>
2.1 Turbo-D	4	65	2068	11	J8S 714, J8S 786, J8S 788	03/86→06/94	<b>UX20A</b>

**AVANTIME**

2.2 dCi	4	110	2188	11	G9T 712	05/02→05/03	<b>UC29A</b>
---------	---	-----	------	----	---------	-------------	--------------

**CLIO**

1.5 dCi	4	48	1461	11	K9K 700, K9K 704	06/01→	<b>UC31A</b>
1.5 dCi	4	50	1461	11	K9K 768	06/05→	<b>UC31A</b>
1.5 dCi	4	60	1461	11	K9K 702	06/01→	<b>UC31A</b>
1.5 dCi	4	63	1461	11	K9K 766	02/08→	<b>UC31A</b>
1.5 dCi	4	74	1461	11	K9K 712	01/04→	<b>UC31A</b>
1.5 dCi	4	76	1461	11		02/08→	<b>UC31A</b>
1.5 dCi	4	78	1461	11	K9K 764	02/08→	<b>UC31A</b>
1.9 D	4	40	1870	11	F8Q 678	01/97→09/98	<b>UX20A</b>
1.9 D	4	47	1870	11	F8Q 730, F8Q 732	01/91→09/98	<b>UX14A</b>
1.9 D	4	47	1870	11	F8Q 630	09/98→	<b>UC21A</b>
1.9 D	4	48	1870	11	F8Q 730, F8Q 732	01/91→09/98	<b>UX22A</b>
1.9 dTi	4	59	1870	11	F9Q 780	02/00→05/05	<b>UC31A</b>

**ESPACE**

1.9 dTi	4	72	1870	11	F9Q 722	02/99→10/02	<b>UC31A</b>
1.9 dCi	4	88	1870	11	F9Q 680, F9Q 820, F9Q 826	11/02→	<b>UC31A</b>
2.1 TD	4	65	2068	11	J8S 610, J8S 772, J8S 776, J8S 778	01/91→10/96	<b>UX20A</b>
2.1 TD	4	66	2068	11	J8S 612	11/94→10/96	<b>UX20A</b>
2.2 12V TD	4	83	2188	11	G8T 714, G8T 716, G8T 760	11/96→10/00	<b>UC8A</b>



### RENAULT

2.2 dCi	4	95	2188	11	G9T 710	10/00→10/02	UC29A
2.2 dCi	4	110	2188	11	G9T 742, G9T 743	11/02→	UC29A

### GRAND SCENIC

1.5 dCi	4	74	1461	11	K9K 728, K9K 729	04/04→	UC31A
1.9 dCi	4	81	1870	11		05/05→	UC31A
1.9 dCi	4	88	1870	11	F9Q 812	04/04→	UC31A
1.9 dCi	4	96	1870	11	F9Q 816, F9Q 818	05/05→	UC31A

### KANGOO

1.5 dCi	4	42	1461	11	K9K 704	12/02→	UC31A
1.5 dCi	4	48	1461	11	K9K 700, K9K 704	12/01→	UC31A
1.5 dCi	4	50	1461	11	K9K 714	06/05→	UC31A
1.5 dCi	4	60	1461	11	K9K 702, K9K 710	07/02→	UC31A
1.5 dCi	4	62	1461	11	K9K 718	06/05→	UC31A
1.5 dCi	4	63	1461	11	K9K 800, K9K 802	02/08→	UC31A
1.5 dCi	4	76	1461	11	K9K 806	02/08→	UC31A
D 55 1.9	4	40	1870	11	F8Q 662	08/97→	UC21A
D 65 1.9	4	47	1870	11	F8Q 630	08/97→	UC21A
D 65 1.9	4	47	1870	11	F8Q 632	08/97→	UC30A
1.9 dCi 4x4	4	59	1870	11	F9Q 782, F9Q 790	10/01→	UC31A
1.9 dTi	4	59	1870	11	F9Q 780	02/00→	UC31A
1.9 dCi 4x4	4	62	1870	11	F9Q 790	07/03→	UC31A

### LAGUNA

1.5 dCi	4	81	1461	11	K9K 780	10/07→	UC31A
1.9 dCi	4	68	1870	11	F9Q 664	03/04→	UC31A
1.9 dTi	4	72	1870	11	F9Q 716	10/97→03/01	UC8A
1.9 dTi	4	72	1870	11	F9Q 710, F9Q 716, F9Q 717	10/97→03/01	UC31A
1.9 dCi	4	74	1870	11	F9Q 754	10/01→	UC31A
1.9 dCi	4	77	1870	11	F9Q 752	06/01→	UC31A
1.9 dCi	4	79	1870	11	F9Q 718	09/99→03/01	UC31A
1.9 dCi	4	79	1870	11	F9Q 718, F9Q 754	03/01→	UC31A
1.9 dCi	4	81	1870	11	F9Q 674	01/05→	UC31A
1.9 dCi	4	88	1870	11	F9Q 750, F9Q 756	03/01→	UC31A
1.9 dCi	4	96	1870	11	F9Q 758, F9Q 759	05/05→	UC31A
2.2 D	4	61	2188	11	G8T 706, G8T 752, G8T 790, G8T 794	11/93→03/01	UC8A
2.2 dT	4	83	2188	11	G8T 760	03/96→03/01	UC8A
2.2 dCi	4	102	2188	11	G9T 600	05/05→	UC31A
2.2 dCi	4	110	2188	11	G9T 700, G9T 702	10/01→	UC29A

**RENAULT**
**MEGANE**

1.9 D	4	47	1870	11	F8Q 620, F8Q 624	01/96→	<b>UX22A</b>
1.9 dTi	4	59	1870	11	F9Q 744	02/01→	<b>UC31A</b>
1.9 dT 8V	4	66	1870	11	F8Q 784/F8Q 786	01/96→	<b>UX18A</b>
1.9 dTi	4	72	1870	11	F9Q 731, F9Q 736	03/97→02/01	<b>UC31A</b>
1.9 dCi	4	75	1870	11	F9Q 732, F9Q 733	02/01→08/03	<b>UC31A</b>

**MEGANE II**

1.5 dCi	4	60	1461	11	K9K 722	11/02→	<b>UC31A</b>
1.5 dCi	4	63	1461	11	K9K 724	05/05→	<b>UC31A</b>
1.5 dCi	4	74	1461	11	K9K 729	10/03→	<b>UC31A</b>
1.5 dCi	4	76	1461	11	K9K 734 FAP Water Heating Plug	01/07→	<b>UX26A</b>
1.5 dCi	4	76	1461	11	K9K 734 FAP	01/07→	<b>UC31A</b>
1.5 dCi	4	78	1461	11	K9K 734 FAP Water Heating Plug	05/05→	<b>UX26A</b>
1.5 dCi	4	78	1461	11	K9K 734 FAP	05/05→	<b>UC31A</b>
1.9 dCi	4	68	1870	11	F9Q 808	03/04→	<b>UC31A</b>
1.9 dCi	4	81	1870	11	F9Q 804, F9Q 816, F9Q 818	05/05→	<b>UC31A</b>
1.9 dCi	4	88	1870	11	F9Q 800	11/02→	<b>UC31A</b>
1.9 dCi	4	96	1870	11	F9Q 803, F9Q 816	05/05→	<b>UC31A</b>

**MEGANE Scenic**

1.9 D	4	47	1870	11	F8Q 620, 624	03/97→09/99	<b>UX22A</b>
1.9 D	4	47	1870	11	F8Q 788	03/97→09/99	<b>UC21A</b>
1.9 D	4	47	1870	11	F8Q 622, 790	03/97→09/99	<b>UC30A</b>
1.9 dT 8V	4	66	1870	11	F8Q 784/F8Q 786	01/97→09/99	<b>UX18A</b>

**MODUS**

1.5 dCi	4	50	1461	11	K9K 768	12/04→	<b>UC31A</b>
1.5 dCi	4	63	1461	11	K9K 766	12/04→	<b>UC31A</b>
1.5 dCi	4	76	1461	11		05/07→	<b>UC31A</b>
1.5 dCi	4	78	1461	11	K9K 764	05/05→	<b>UC31A</b>

**SAFRANE**

2.1 dT	4	65	2068	11	J8S 760	11/93→07/96	<b>UX20A</b>
2.2 dT	4	83	2188	11	G8T 740	07/96→12/00	<b>UC8A</b>
2.5 dT	4	83	2500	11	S8U 762, S8U 763	12/92→07/96	<b>UX20A</b>

**SCENIC**

1.9 dTi	4	59	1870	11	F9Q 744	02/01→08/03	<b>UC31A</b>
1.9 dTi	4	72	1870	11	F9Q 734	09/99→08/03	<b>UC8A</b>
1.9 dTi	4	72	1870	11	F9Q 731, F9Q 736	09/99→08/03	<b>UC31A</b>



RENAULT							
1.9 dCi	4	75	1870	11	F9Q 732, F9Q 733	11/00→08/03	UC31A
1.9 dCi RX4	4	75	1870	11	F9Q 740	11/00→08/03	UC31A
SCENIC II							
1.5 dCi	4	60	1461	11	K9K 722	06/03→	UC31A
1.5 dCi	4	63	1461	11	K9K 722, K9K 724	05/05→	UC31A
1.5 dCi	4	74	1461	11	K9K 728, K9K 729	11/03→	UC31A
1.5 dCi	4	76	1461	11	K9K 728	01/07→	UC31A
1.5 dCi	4	78	1461	11	K9K 732	05/05→	UC31A
1.9 dCi	4	81	1870	11	F9Q 803	05/05→	UC31A
1.9 dCi	4	88	1870	11	F9Q 812	06/03→	UC31A
1.9 dCi	4	96	1870	11	F9Q 804	05/05→	UC31A
THALIA							
1.5 dCi	4	48	1461	11	K9K 700	04/02→	UC31A
1.5 dCi	4	50	1461	11		02/03→	UC31A
1.5 dCi	4	60	1461	11	K9K 702	06/01→	UC31A
TWINGO							
1.5 dCi	4	47	1461	11	K9K 740	03/07→	UC31A
VEL SATIS							
2.2 dCi	4	85	2188	11	G9T 600	04/04→	UC29A
2.2 dCi	4	102	2188	11	G9T 600, G9T 700	09/04→	UC29A
2.2 dCi	4	110	2188	11	G9T 702	06/02→	UC29A
MASTER							
1.9 dTi	4	59	1870	11	F9Q 770	09/00→	UC31A
1.9 dCi 80	4	60	1870	11	F9Q 772	11/01→	UC31A
28-35 2.1 D	4	44	2068	11	J8S 330	01/86→07/98	UX20A
2.2 dCi 90	4	66	2188	11	G9T 722	09/00→	UC29A
28-35 2,5 D	4	55	2499	11	S8U 742	08/89→07/98	UX20A
35 2,5 TD	4	69	2499	11,5	8140.27.2500, 8140.27.2510, S9U 714	08/89→07/98	UX11A
28-35 2,5 TD	4	72	2499	11	8140.27.2580	08/89→07/98	UX20A
28-35 2.5 D	4	55	2499	11	S8U 742	08/89→07/98	UX20A
35 2,5 TD	4	69	2499	11,5	8140.27.2500, 8140.27.2510, S9U 714	08/89→07/98	UX11A
28-35 2,5 TD	4	72	2499	11	8140.27.2580	08/89→07/98	UX20A
28-35 2.5 D	4	52	2445	11	8140.61.2300, S8U 731	09/80→07/98	UX20A
2.5 D	4	59	2499	11	S8U 770	07/98→01/01	UC37A
2.5 dCi 120	4	84	2463	11	G9U 720, G9U 754	10/01→	UC29A
2.5 dCi 100	4	73	2463	11	G9U 754	10/03→	UC29A
2.8 dTi	4	84	2799	11	S9W 702	07/98→10/01	UC37A



## RENAULT

### RAPID

1.6 D (F404)	4	40	1596	11	F8M 720, F8M 730, F8M 736, F8M 760	03/86→08/98	UX14A
1.9 D (F40R)	4	40	1870	11	F8Q 640, F8Q 682	09/94→03/98	UX22A
1.9 D (F40P, F40N, F40E)	4	47	1870	11	F8Q 722, F8Q 724, F8Q 774, F8Q 776	09/91→03/98	UX14A

### TRAFIC

1.9 D	4	44	1870	11	F8Q 606	06/97→03/01	UC21A
1.9 dCi 80	4	60	1870	11	F9Q 762	03/01→	UC31A
1.9 dCi 100	4	74	1870	11	F9Q 760	03/01→	UC31A
2.1 D	4	43	2068	11	852 750	05/89→06/94	UX20A
2.1 D	4	47	2068	11	J8S 620, J8S 758	06/94→10/97	UX20A
2.5 D	4	51	2445	11,5	S8U 720	05/89→03/01	UX11A
2.5 D	4	55	2499	11,5	S8U 750, S8U 752, S8	05/89→03/01	UX11A
2.5 D	4	55	2499	11	Sofim-8140.67.2500	05/89→03/01	UX20A
2.5 D 4x4	4	55	2499	11,5	S8U 752, S8U 750	05/89→03/01	UX11A
2.5 D 4x4	4	55	2499	11	Sofim-8140.67.2580	05/89→03/01	UX20A
2.5 dCi 135	4	99	2464	11	G9U 730	05/03→	UC29A

## ROVER

### 25

2.0 iDT	4	74	1994	11	20 T2N	10/99→	UC8A
---------	---	----	------	----	--------	--------	------

### 45

2.0 iDT	4	74	1994	11	20 T2N	02/00→	UC8A
---------	---	----	------	----	--------	--------	------

### 75

2.0 CDT	4	85	1950	11	M 47 R	02/99→	UC26A
---------	---	----	------	----	--------	--------	-------

2.0 CDTi	4	96	1951	11	204D2	02/03→	UC26A
----------	---	----	------	----	-------	--------	-------

### 100 (METRO)

114 D	4	38	1361	11,5	TUD 3	10/92→12/94	UX11A
-------	---	----	------	------	-------	-------------	-------

115 D	4	42	1527	11	TUD 5	12/94→12/98	UC15A
-------	---	----	------	----	-------	-------------	-------

### 200

218 D	4	52	1905	11		09/91→10/95	UX20A
-------	---	----	------	----	--	-------------	-------

218 TD	4	65	1769	11	XUD 7TE	09/91→10/95	UX20A
--------	---	----	------	----	---------	-------------	-------

220 D/SD	4	63	1994	11	20 T2R	11/95→03/00	UC8A
----------	---	----	------	----	--------	-------------	------

220 SDi	4	77	1994	11	20 T2N	11/95→03/00	UC8A
---------	---	----	------	----	--------	-------------	------

### 400

418 D	4	49	1905	11		09/91→04/95	UX20A
-------	---	----	------	----	--	-------------	-------

418 TD	4	65	1769	11	XUD 7TE	09/91→11/98	UX20A
--------	---	----	------	----	---------	-------------	-------

420 D	4	63	1994	11	20 T2R	11/95→03/00	UC8A
-------	---	----	------	----	--------	-------------	------



## ROVER

420 Di	4	77	1994	11	20 T2N	05/95→03/00	UC8A
--------	---	----	------	----	--------	-------------	------

## 600

620 Sdi	4	77	1994	11	20 T2N	12/94→02/99	UC8A
---------	---	----	------	----	--------	-------------	------

## 800 (XS)

825 D/SD (XS)	4	87	2500	11	425 SL1RR, 492 4 SHIRG	01/90→11/91	UX7A
---------------	---	----	------	----	------------------------	-------------	------

825 D/SD (XS)	4	87	2500	11	425 SL1RR, 492 4 SHIRG	12/91→04/95	UX20A
---------------	---	----	------	----	------------------------	-------------	-------

825 D/SD (XS)	4	87	2500	11	425 SL1RR, 492 4 SHIRG	05/95→	UC14A
---------------	---	----	------	----	------------------------	--------	-------

825 SD	4	87	2500	11	425 SL1RR, 492 4 SHIRG	05/95→02/99	UC14A
--------	---	----	------	----	------------------------	-------------	-------

825 SD	4	87	2500	11	425 SL1RR, 492 4 SHIRG	09/93→04/95	UX20A
--------	---	----	------	----	------------------------	-------------	-------

## MAESTRO

2.0 D	4	44	1994	11		09/90→10/92	UX20A
-------	---	----	------	----	--	-------------	-------

2.0 TD	4	60	1994	11	BB	09/90→01/95	UX20A
--------	---	----	------	----	----	-------------	-------

## MONTEGO

2.0 D Turbo	4	60	1996	11	BB	10/88→10/95	UX20A
-------------	---	----	------	----	----	-------------	-------

## STREETWISE

2.0 TD	4	74	1994	11	20 T2N	08/03→	UC8A
--------	---	----	------	----	--------	--------	------

## SAAB

### 9-3

1.9 TiD	4	88	1910	11	Z19DT	09/04→	UY3A
---------	---	----	------	----	-------	--------	------

1.9 TiD	4	110	1910	11	Z19DTH	09/04→	UY3A
---------	---	-----	------	----	--------	--------	------

2.2 TiD	4	85	2171	11	D223L, X 22 DTH	02/98→11/00	UC16A
---------	---	----	------	----	-----------------	-------------	-------

2.2 TiD	4	92	2171	11	D223L	11/00→09/02	UC28A
---------	---	----	------	----	-------	-------------	-------

2.2 TiD	4	92	2171	11	D223L	09/02→	UC28A
---------	---	----	------	----	-------	--------	-------

### 9-5

2.2 TiD	4	88	2171	11	D223L	03/02→	UC16A
---------	---	----	------	----	-------	--------	-------

## SEAT

### ALHAMBRA

1.9 TDI	4	66	1896	11	1Z, AHU, ANU	04/96→09/01	UC31A
---------	---	----	------	----	--------------	-------------	-------

1.9 TDI	4	81	1896	11	AFN	08/96→06/00	UC31A
---------	---	----	------	----	-----	-------------	-------

1.9 TDI	4	85	1896	11	AUY, BVK	06/00→	UC31A
---------	---	----	------	----	----------	--------	-------

1.9 TDI 4motion	4	85	1896	11	AUY	02/01→	UC31A
-----------------	---	----	------	----	-----	--------	-------

1.9 TDI	4	96	1896	11	ASZ	11/02→	UC14A
---------	---	----	------	----	-----	--------	-------

1.9 TDI	4	110	1896	5	ARL, BTB	05/05→	UC01F
---------	---	-----	------	---	----------	--------	-------

### ALTEA

1.9 TDI	4	77	1896	5	BJB, BKC, BLS, BXE	04/04→	UC01F
---------	---	----	------	---	--------------------	--------	-------

2.0 TDI	4	100	1968	4,4	AZV	03/04→	UC03F
---------	---	-----	------	-----	-----	--------	-------

2.0 TDI 16V	4	103	1968	4,4	BKD	03/04→	UC03F
-------------	---	-----	------	-----	-----	--------	-------



<b>SEAT</b>							
<b>AROSA</b>							
1.4 TDI	3	55	1422	11	AMF	01/00→10/01	<b>UC31A</b>
1.4 TDI	3	55	1422	11	AMF	11/01→	<b>UC14A</b>
1.7 SDI	4	44	1716	11	AKU	08/97→06/04	<b>UC31A</b>
<b>CORDOBA</b>							
1.4 TDI	3	51	1422	11	BNM	05/05→	<b>UC14A</b>
1.4 TDI	3	55	1422	11	AMF	10/02→	<b>UC14A</b>
1.4 TDI	3	59	1422	11	BMS, BNV	06/05→	<b>UC14A</b>
1.7 SDI	4	44	1716	11		07/97→06/99	<b>UC31A</b>
1.9 D	4	47	1896	11	1Y	01/96→08/96	<b>UX25A</b>
1.9 SDI	4	47	1896	11	AEY	08/96→06/99	<b>UC31A</b>
1.9 SDI	4	47	1896	11	ASY	09/02→	<b>UC14A</b>
1.9 D 8V	4	50	1896	11	1Y	02/93→08/96	<b>UX8A</b>
1.9 D	4	50	1896	11	1Y	02/93→08/96	<b>UX25A</b>
1.9 SDI	4	50	1896	11	AGP, AQM	06/99→10/02	<b>UC31A</b>
1.9 TD 8V	4	55	1896	11	AAZ	02/93→08/96	<b>UX8A</b>
1.9 TD	4	55	1896	11	AAZ	02/93→08/96	<b>UX25A</b>
1.9 TDI	4	66	1896	11	1Z, AHU	08/96→06/99	<b>UC31A</b>
1.9 TDI	4	66	1896	11	AGR, ALH	06/99→10/02	<b>UC31A</b>
1.9 TDI	4	74	1896	11	ATD, AXR, BMT	09/02→	<b>UC14A</b>
1.9 TDI	4	81	1896	11	AFN	03/97→06/99	<b>UC31A</b>
1.9 TDI	4	81	1896	11	ASK, ASV	06/99→10/02	<b>UC31A</b>
1.9 TDI	4	96	1896	11	ASZ, BLT	10/02→	<b>UC14A</b>
<b>IBIZA I</b>							
1.7 D	4	42	1714	11	022 A.5000	08/90→05/93	<b>UX20A</b>
<b>IBIZA II</b>							
1.7 SDI	4	44	1716	11		07/97→08/99	<b>UC31A</b>
1.9 D	4	47	1896	11	1Y	04/93→08/96	<b>UX25A</b>
1.9 SDI 8V	4	47	1896	11	AEF	08/96→08/99	<b>UX8A</b>
1.9 SDI	4	47	1896	11	AEF	08/96→08/99	<b>UX25A</b>
1.9 SDI	4	47	1896	11	AEY	08/96→08/99	<b>UC31A</b>
1.9 D 8V	4	50	1896	11	1Y	10/94→08/96	<b>UX8A</b>
1.9 D	4	50	1896	11	1Y	10/94→08/96	<b>UX25A</b>
1.9 TD 8V	4	55	1896	11	AAZ	03/93→08/96	<b>UX8A</b>
1.9 TD	4	55	1896	11	AAZ	03/93→08/96	<b>UX25A</b>
1.9 TDI	4	66	1896	11	1Z, AHU	08/96→08/99	<b>UC31A</b>
1.9 TDI	4	81	1896	11	AFN	02/97→08/99	<b>UC31A</b>

**SEAT**
**IBIZA III**

1.9 SDI	4	50	1896	11	AGP, AQM	08/99→02/02	<b>UC31A</b>
1.9 TDI	4	66	1896	11	AGR, ALH	08/99→02/02	<b>UC31A</b>
1.9 TDI	4	81	1896	11	ASK, ASV	08/99→02/02	<b>UC31A</b>

**IBIZA IV**

1.4 TDI	3	51	1422	11	BNM	05/05→	<b>UC14A</b>
1.4 TDI	3	55	1422	11	AMF	05/02→	<b>UC14A</b>
1.4 TDI	3	59	1422	11	BMS, BNV	06/05→	<b>UC14A</b>
1.9 SDI	4	47	1896	11	ASY	02/02→	<b>UC14A</b>
1.9 TDI	4	74	1896	11	ATD, AXR, BMT	02/02→	<b>UC14A</b>
1.9 TDI	4	96	1896	11	ASZ, BLT	02/02→	<b>UC14A</b>
1.9 TDI Cupra R	4	110	1896	11	ARL	01/04→	<b>UC31A</b>
1.9 TDI Cupra R	4	118	1896	5	BPX, BUK	03/04→	<b>UC01F</b>

**LEON**

1.9 SDI	4	50	1896	11	AQM	11/99→	<b>UC31A</b>
1.9 TDI	4	66	1896	11	AGR, ALH	11/99→	<b>UC31A</b>
1.9 TDI	4	74	1896	5	AXR	10/05→	<b>UC01F</b>
1.9 TDI	4	77	1896	5	BKC, BLS, BXE	09/05→	<b>UC01F</b>
1.9 TDI	4	81	1896	11	AHF, ASV	11/99→	<b>UC31A</b>
1.9 TDI	4	96	1896	11	ASZ	05/03→	<b>UC14A</b>
1.9 TDI	4	110	1896	11	ARL	02/01→	<b>UC31A</b>
1.9 TDI Syncro	4	110	1896	11	ARL	05/02→	<b>UC31A</b>
2.0 TDI 16V	4	103	1968	4,4	BKD	09/05→	<b>UC03F</b>

**MALAGA**

1.7 D	4	40	1714	11	022 A.5000	05/85→12/93	<b>UX20A</b>
1.7 D	4	42	1714	11	022 A.5000	05/90→12/93	<b>UX20A</b>

**TOLEDO I**

1.9 D	4	47	1896	11	1Y	12/95→03/99	<b>UX25A</b>
1.9 SDI	4	47	1896	11	1Y	12/95→03/99	<b>UC31A</b>
1.9 D 8V	4	50	1896	11	1Y	05/91→03/99	<b>UX8A</b>
1.9 D	4	50	1896	11	1Y	05/91→03/99	<b>UX25A</b>
1.9 TD 8V	4	55	1896	11	AAZ	05/91→03/99	<b>UX8A</b>
1.9 TD	4	55	1896	11	AAZ	05/91→03/99	<b>UX25A</b>
1.9 TDI	4	66	1896	11	1Z, AHU	08/95→03/99	<b>UC31A</b>
1.9 TDI	4	81	1896	11	AFN	11/96→03/99	<b>UC31A</b>

**TOLEDO II**

1.9 SDI	4	50	1896	11	AQM	11/99→06/04	<b>UC31A</b>
1.9 TDI	4	66	1896	11	AGR, ALH	04/99→05/06	<b>UC31A</b>
1.9 TDI	4	81	1896	11	AHF, ASV	04/99→05/06	<b>UC31A</b>





SEAT								
1.9 TDI	4	96	1896	11	ASZ		05/03→05/06	UC14A
1.9 TDI	4	110	1896	11	ARL		10/00→05/06	UC31A
TOLEDO III								
1.9 TDI	4	77	1896	5	BJB, BKC, BLS, BXE		10/04→	UC01F
2.0 TDI 16V	4	103	1968	4,4	BKD		10/04→	UC03F
INCA								
1.7 D	4	42	1716	11	AHB		09/96→	UX25A
1.9 D	4	47	1896	11	1Y		11/95→	UX25A
1.9 SDI	4	47	1896	11	AEY, AYQ		11/95→	UC31A
1.9 TDI	4	66	1896	11	ALH		09/96→	UC31A
TERRA								
1.3 D	4	33	1272	11	MN		03/90→12/94	UX25A
1.4 D	4	35	1398	11	1 W		10/90→12/95	UX25A

SKODA								
FABIA								
1.4 TDI	3	51	1422	11	BNM		10/05→	UC14A
1.4 TDI	3	55	1422	11	AMF		04/03→	UC14A
1.4 TDI	3	59	1422	11	BNV		10/05→	UC14A
1.9 SDI	4	47	1896	11	ASY		11/99→	UC31A
1.9 TDI	4	74	1896	11	ATD, AXR		01/00→	UC31A
1.9 TDI RS	4	96	1896	11	ASZ, BLT		06/03→	UC14A
FELICIA								
1.9 D 8V	4	47	1896	11	AEF		10/95→06/01	UX8A
1.9 D	4	47	1896	11	AEF		10/95→06/01	UX25A
OCTAVIA								
1.9 SDI	4	50	1896	11	AGR, AQM		06/97→	UC31A
1.9 TDI	4	66	1896	11	AGR, ALH		09/96→	UC31A
1.9 TDI 4x4	4	66	1896	11	AGR		11/99→09/00	UC31A
1.9 TDI 4x4	4	74	1896	11	ATD		12/02→	UC14A
1.9 TDI 4x4	4	74	1896	11	ATD		09/00→11/02	UC31A
1.9 TDI	4	77	1896	5	BJB, BKC 70251®		06/04→	UC01F
1.9 TDI 4x4	4	77	1896	5	BKC 70251®		11/04→	UC01F
1.9 TDI	4	81	1896	11	AHF, ASV		08/97→	UC31A
1.9 TDI	4	96	1896	11	ASZ		01/03→	UC14A
2.0 TDI 16V	4	103	1968	4,4	BKD		02/04→	UC03F
ROOMSTER								
1.4 TDI	3	51	1422	11	BNM		07/06→	UC14A
1.4 TDI	3	59	1422	11	BMS, BNV		09/06→	UC14A

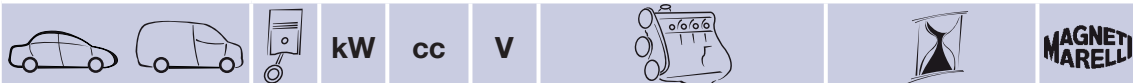

SKODA								
1.9 TDI	4	77	1896	5	BLS, BSW	09/06→		UC01F
SUPERB								
1.9 TDI	4	74	1896	11	AVB	08/02→		UC14A
1.9 TDI	4	96	1896	11	AWX	02/02→		UC14A
2.5 TDI	6	114	2496	11	AYM	02/02→		UC45A
2.5 TDI	6	120	2496	11	BDG	06/03→		UC45A

SMART								
CABRIO								
0.8 CDI	3	30	799	11,5	OM 660 DE 8LA	03/01→01/04		UC39A
CITY-COUPÉ								
0.8 CDI	3	30	799	11,5	OM 660 DE 8LA	11/99→01/04		UC39A
FORTWO Cabrio								
0.8 CDI	3	30	799	11,5	OM 660 DE 8LA	01/04→		UC39A
0.8 CDI	3	30	799	11,5		01/07→		UC39A
FORTWO Coupé								
0.8 CDI	3	30	799	11,5	OM 660 DE 8LA	01/04→		UC39A
0.8 CDI	3	30	799	11,5		01/07→		UC39A

SSANGYONG								
KORANDO								
2.2 D	4	50	2238	11	DC23	12/88→12/96		UC10A
2.3 D 8V	4	58	2299	11,5	OM 601.940	12/96→		UX13A
2.9 D 10V	5	72	2874	11,5	MB-OM 662	12/96→		UX13A
MUSSO								
2.3 D 8V	4	59	2299	11,5	MB-OM 661/OM 601.940	10./95→		UX13A
2.9 D 10V	5	73	2874	11,5	MB-OM 662	03/96→		UX13A

SUZUKI								
BALENO								
1.9 TD	4	55	1905	11		04/98→05/02		UX20A
GRAND VITARA								
2.0 HDI 110	4	80	1997	11	RHW	07/01→		UC12A
SAMURAI								
1.9 TD	4	46	1905	11	XUD9	11/98→		UX20A
SX4								
1.9 DDiS	4	88	1910	11	D19AA	06/06→		UC19A
1.9 DDiS 4x4	4	88	1910	11	D19AA	06/06→		UC19A



kW

cc

V

MAGNETI  
MARELLI**SUZUKI****VITARA**

1.9 D	4	50	1905	11	XUD9A	01/95→03/98	<b>UX20A</b>
1.9 D	4	50	1905	11	XUD9A	09/98→	<b>UX20A</b>
1.9 D	4	55	1905	11	XUD9SD	08/96→03/99	<b>UX20A</b>

**WAGON R+**

1.3 DDiS	4	51	1248	11	Z13DT	09/03→	<b>UY2A</b>
----------	---	----	------	----	-------	--------	-------------

**TOYOTA****AVENSIS**

2.0 TD	4	66	1975	11	2C-TE	09/97→02/03	<b>UC38A</b>
2.0 D-4D	4	81	1995	11	1CD-FTV	10/99→01/03	<b>UC35A</b>
2.0 D-4D	4	85	1995	11	1CD-FTV	08/01→	<b>UC35A</b>

**AYGO**

1.4 HDi	4	40	1398	11		07/05→	<b>UY1A</b>
---------	---	----	------	----	--	--------	-------------

**CARINA E**

2.0 D	4	54	1975	11	2C	04/92→01/96	<b>UC38A</b>
2.0 TD	4	61	1975	11	2C-T	01/96→09/97	<b>UC38A</b>

**COROLLA**

1.4 D	4	66	1364	11	1ND-TV	07/04→	<b>UC32A</b>
1.8 D	4	47	1840	11	1C	07/87→06/93	<b>UC38A</b>
1.8 D	4	49	1840	11	1C	08/89→04/92	<b>UC38A</b>
1.9 D (WZE110_)	4	51	1867	11	1WZ	02/00→01/02	<b>UC15A</b>
2.0 D (CE100_)	4	53	1975	11	2C	07/92→04/97	<b>UC38A</b>
2.0 D (CE110_)	4	53	1975	11	2C-E	04/97→02/00	<b>UC38A</b>
2.0 D-4D	4	66	1995	11	1CD-FTV	07/01→01/02	<b>UC35A</b>
2.0 D-4D	4	66	1995	11	1CD-FTV	09/01→01/02	<b>UC35A</b>
2.0 D-4D	4	66	1995	11	1CD-FTV	01/02→05/04	<b>UC35A</b>
2.0 D-4D	4	66	1995	11	1CD-FTV	01/02→	<b>UC35A</b>
2.0 D-4D	4	66	1995	11	1CD-FTV	08/02→	<b>UC4A</b>
2.0 D-4D	4	81	1995	11	1CD-FTV	01/02→	<b>UC35A</b>
2.0 D-4D	4	85	1995	11	1CD-FTV	05/03→	<b>UC35A</b>

**LAND CRUISER**

3.0 D-4D	4	120	2982	11	1KD-FTV	10/00→	<b>UC35A</b>
4.2 D (HZJ80_)	6	99	4164	11	1H-Z	01/90→12/97	<b>UC38A</b>
4.2 TD (HDJ80)	6	118	4164	11	1HD-T	10/92→12/97	<b>UC38A</b>
4.2 TD (HDJ80)	6	123	4164	11	1HD-T	01/90→12/97	<b>UC38A</b>

**PREVIA**

2.0 D-4D	4	85	1995	11	1CD-FTV	03/01→	<b>UC35A</b>
----------	---	----	------	----	---------	--------	--------------



TOYOTA								
RAV 4								
2.0 D-4D 4WD	4	85	1995	11	1CD-FTV	09/01→		UC35A
YARIS								
1.4 D-4D	4	55	1364	11	1ND-TV	12/01→		UC32A
D-4D	4	66	1364	11	1ND-TV	01/06→		UC32A
HIACE IV								
2.5 D-4D	4	65	2494	11	2KD-FTV	11/01→		UC35A
2.5 D-4D	4	75	2494	11	2KD-FTV	11/01→		UC35A
HILUX Pickup								
2.5 D-4D	4	65	2494	11	2KD-FTV	11/01→		UC35A
2.5 D-4D 4WD	4	75	2494	11	2KD-FTV	11/01→		UC35A

VAUXHALL								
ARENA								
1.9 D	4	44	1870	11	F8Q 600, F8Q 606	03/98→11/99		UX22A
2.5 D	4	55	2499	11	S8U 758, S8U 780, S8U 782	03/98→11/99		UX20A
ASTRA Mk III								
1.7 D	4	42	1699	11	17 D	12/91→02/98		UX20A
1.7 D	4	44	1699	11	17 DR	09/91→12/94		UX20A
1.7 TD	4	50	1700	11	X 17 DTL 817253®	11/94→09/98		UC9A
1.7 TD	4	60	1686	11	17 DT (TC4EE1) 817253®	12/91→09/98		UC9A
ASTRA Mk IV								
1.7 TD	4	50	1700	11	X 17 DTL	09/98→08/00		UX20A
1.7 DTI 16V	4	55	1686	11	Y 17 DT	02/00→		UZ2A
1.7 CDTI 16V	4	59	1686	11	Z 17 DTL	04/03→		UZ2A
2.0 DI	4	60	1995	11	X 20 DTL, Y 20 DTL	02/98→03/04		UC16A
2.0 DTI 16V	4	74	1995	11	X 20 DTH, Y 20 DTH	08/99→		UC16A
ASTRA MK V								
1.3 CDTI	4	66	1248	11	Z 13 DTH	08/05→		UY2A
1.7 CDTI	4	59	1686	11	Z 17 DTL	03/04→		UZ2A
1.7 CDTI	4	74	1686	11	Z 17 DTH	03/04→		UZ2A
1.9 CDTI	4	88	1910	11	Z 19 DT	09/05→		UY3A
1.9 CDTI 16V	4	88	1910	11	Z 19 DTJ	08/04→		UY3A
1.9 CDTI	4	110	1910	11	Z 19 DTH	06/04→		UY3A
CAVALIER Mk III								
1.7 D	4	42	1699	11	17 D	09/88→09/92		UX20A
1.7 D	4	44	1700	11	17 DR	07/92→11/95		UX20A
1.7 TD	4	60	1686	11	17 DT (TC4EE1) 817253®	09/88→11/95		UC9A



VAUXHALL							
CORSA							
1.5 D	4	37	1488	11	15 D (4EC1)	03/93→09/00	UZ1A
1.5 TD	4	49	1488	11	15 DT (T4EC1), X 15 DT (T4EC1)	03/93→10/96	UZ1A
1.7 D	4	44	1686	11	17 D (4EE1), X 17 D (4EE1)	02/96→09/00	UZ1A
CORSA Mk II							
1.3 CDTI 16V	4	52	1248	11	Z 13 DT	04/04→	UY2A
1.7 DI 16V	4	48	1686	11	Y 17 DTL	09/00→	UZ2A
1.7 DTI 16V	4	55	1686	11	Y 17 DT	09/00→	UZ2A
1.7 CDTI 16V	4	74	1686	11	Z 17 DTH	04/04→	UZ2A
CORSA Mk III							
1.3 CDTI	4	55	1248	11	Z 13 DTJ	07/06→	UY2A
1.3 CDTI	4	66	1248	11	Z 13 DTH	07/06→	UY2A
1.7 CDTI	4	92	1686	11	A 17 DTR	07/06→	UZ2A
FRONTERA							
2.2 DTI	4	85	2171	11	X 22 DTH	10/98→	UC16A
2.2 DTI	4	92	2171	11	Y 22 DTH	08/00→	UC28A
2.3 TD	4	74	2260	11	23 DTR	03/92→10/98	UX20A
2.5 TDS	4	85	2499	11	25TDS (VM41B)	09/96→10/98	UC14A
MERIVA							
1.3 CDTI	4	55	1248	11	Z 13 DTH	09/03→	UY2A
1.7 DTI 16V	4	55	1686	11	Y 17 DT	09/02→	UZ2A
1.7 CDTI 16V	4	74	1686	11	Z 17 DTH	09/03→	UZ2A
1.7 CDTI 16V	4	74	1686	11	Z 17 DTH	04/04→	UZ2A
MONTEREY							
3.1 TD	4	84	3059	11	4 JG2TC	09/91→07/98	UC9A
NOVA							
1.5 D	4	37	1488	11	15 D (4EC1) 804795®	09/87→02/93	UC10A
1.5 TD	4	49	1488	11	15 DT (T4EC1)	01/90→02/93	UC9A
OMEGA							
2.0 DTI 16V	4	74	1995	11	X 20 DTH	10/98→09/00	UC16A
2.2 DTI 16V	4	88	2171	11	Y 22 DTH	09/00→	UC28A
2.5 TD	6	96	2497	11	25 DT, X 25 DT	04/94→02/01	UX20A
SIGNUM							
2.0 DTI	4	74	1994	11	Y 20 DTH	05/03→	UC28A
1.9 CDTI	4	88	1910	11	Z 19 DT	04/04→	UC19A
1.9 CDTI 16V	4	110	1910	11	Z 19 DTH	04/04→	UY3A
2.2 DTI	4	92	2188	11	Y 22 DTR	05/03→	UC28A

**VAUXHALL**
**SINTRA**

2.2 DTI	4	85	2171	11	X 22 DTH	07/97→04/99	<b>UC16A</b>
---------	---	----	------	----	----------	-------------	--------------

**TIGRA TwinTop**

1.3 CDTI	4	51	1248	11	Z 13 DT	06/04→	<b>UY2A</b>
----------	---	----	------	----	---------	--------	-------------

**VECTRA**

1.7 TD	4	60	1686	11	X 17 DT (TC4EE1)	10/95→11/96	<b>UZ1A</b>
1.7 TD	4	60	1686	11	X 17 DT	08/95→12/96	<b>UC16A</b>
1.9 CDTI	4	88	1910	11	Z 19 DT	04/04→	<b>UY3A</b>
1.9 CDTI 16V	4	110	1910	11	Z 19 DTH	04/04→	<b>UY3A</b>
2.0 DI 16V	4	60	1995	11	X 20 DTL	11/96→	<b>UC16A</b>
2.0 DTI 16V	4	74	1995	11	X 20 DTH	03/98→	<b>UC16A</b>
2.0 DTI 16V	4	74	1995	11	Y 20 DTH	08/99→	<b>UC28A</b>
2.0 DTI 16V	4	74	1995	11	Y 20 DTH	04/02→	<b>UC28A</b>
2.2 DTI 16V	4	92	2172	11	Y 22 DTR	09/00→	<b>UC16A</b>
2.2 DTI 16V	4	92	2172	11	Y 22 DTR	09/00→	<b>UC28A</b>
2.2 DTI 16V	4	92	2172	11	Y 22 DTR	10/03→	<b>UC28A</b>

**ZAFIRA**

1.9 CDTI	4	88	1910	11	Z 19 DT	07/05→	<b>UC19A</b>
2.0 DI 16V	4	60	1995	11	X 20 DTL	10/99→	<b>UC16A</b>
2.0 DTI 16V	4	74	1995	11	Y 20 DTH	04/99→	<b>UC16A</b>
2.2 DTI	4	85	2171	11	X 22 DTH	09/99→	<b>UC16A</b>
2.2 DTI 16V	4	92	2172	11	Y 22 DTR	01/02→	<b>UC28A</b>

**BRAVA**

2.2 D	4	39	2238	11	C223	08/91→09/96	<b>UC10A</b>
2.2 D 4x4	4	39	2238	11	C223	08/91→09/96	<b>UC10A</b>
2.5 D	4	56	2499	11	4 JA1	08/91→06/94	<b>UX20A</b>
2.5 D 4x4	4	56	2499	11	4 JA1T	06/90→06/94	<b>UX20A</b>
2.5 TD	4	56	2499	11	4 JA1T	07/94→	<b>UX20A</b>
2.5 TD 4x4	4	56	2499	11	4 JA1T	07/94→	<b>UX20A</b>

**COMBO**

1.7 D	4	44	1686	11	17 D (4EE1), X 17 D (4EE1)	07/94→10/01	<b>UZ2A</b>
1.7 DI 16V	4	48	1686	11	Y 17 DTL	09/01→	<b>UX20A</b>
1.7 DTI 16V	4	55	1686	11	Y 17 DT	10/01→	<b>UZ2A</b>

**MOVANO**

1.9 DTI	4	59	1870	11	F9Q 770	09/00→10/01	<b>UC31A</b>
1.9 DTI	4	60	1870	11	F9Q 774	10/01→	<b>UC31A</b>
2.2 DTI	4	66	2188	11	G9T 720	09/00→	<b>UC29A</b>
2.5 DTI	4	84	2463	11	G9U 720, G9U 724, G9U 754	10/01→	<b>UC29A</b>
2.5 D	4	59	2499	11	S8U 770	10/98→09/00	<b>UX20A</b>



VAUXHALL							
2.8 DTI	4	84	2799	11	S9W 702	10/98→10/01	UX20A
VIVARO							
1.9 DI	4	59	1900	11		08/01→	UC31A
1.9 DTI	4	74	1870	11	F9Q 760	08/01→	UC31A
2.5 DTI	4	99	2463	11	G9U 730	04/04→	UC29A

VOLKSWAGEN							
BORA							
1.9 SDI	4	50	1896	11	AGP, AQM	10/98→05/05	UC31A
1.9 TDI	4	66	1896	11	AGR, ALH, ANU	10/98→06/01	UC31A
1.9 TDI 4motion	4	66	1896	11	AGR	02/99→06/01	UC31A
1.9 TDI	4	74	1896	11	ATD, AXR	09/00→05/05	UC14A
1.9 TDI 4motion	4	74	1896	11	ATD	09/00→05/05	UC14A
1.9 TDI	4	81	1896	11	AHF, ASV	10/98→06/01	UC31A
1.9 TDI	4	85	1896	11	AJM, AUY	12/98→06/01	UC31A
1.9 TDI 4motion	4	85	1896	11	AJM, AUY	02/99→06/01	UC31A
1.9 TDI	4	96	1896	11	ASZ ®172.600000	11/00→05/05	UC31A
1.9 TDI	4	96	1896	11	ASZ 172.600001®	11/00→05/05	UC14A
1.9 TDI 4motion	4	96	1896	11	ASZ ®172.600000	11/00→05/05	UC31A
1.9 TDI 4motion	4	96	1896	11	ASZ 172.600001®	11/00→05/05	UC14A
1.9 TDI	4	110	1896	11	ARL	05/00→10/01	UC31A
1.9 TDI	4	110	1896	11	ARL	11/01→05/05	UC14A
1.9 TDI 4motion	4	110	1896	11	ARL	05/00→10/01	UC31A
1.9 TDI 4motion	4	110	1896	11	ARL	11/01→05/05	UC14A
EOS							
2.0 TDI	4	103	1968	4,4	BMM	06/06→	UC03F
FOX							
1.4 TDI	3	51	1422	11	BNM	04/05→	UC14A
GOLF III							
1.9 SDI	4	47	1896	11	AEY	07/95→04/99	UC31A
1.9 D 8V	4	48	1896	11	1Y	11/91→08/97	UX8A
1.9 D	4	48	1896	11	1Y	11/91→04/99	UX25A
1.9 TD,GTD 8V	4	55	1896	11	AAZ	11/91→08/97	UX8A
1.9 TD	4	55	1896	11	AAZ	11/91→04/99	UX25A
1.9 TDI	4	66	1896	11	1Z, AHU, ALE	09/93→05/98	UC31A
1.9 TDI Syncro	4	66	1896	11	1Z, AHU, ALE	08/95→04/99	UC31A
1.9 TDI	4	81	1896	11	AFN	04/96→04/99	UC31A

**kW**
**cc**
**V**

**VOLKSWAGEN**
**GOLF IV**

1.9 SDI	4	50	1896	11	AGP, AQM	08/97→06/05	<b>UC31A</b>
1.9 TDI	4	66	1896	11	AGR, ALH	10/97→05/06	<b>UC31A</b>
1.9 TDI 4motion	4	66	1896	11	AGR, ALH	07/98→04/02	<b>UC31A</b>
1.9 TDI	4	74	1896	11	ATD, AXR	09/00→10/01	<b>UC31A</b>
1.9 TDI	4	74	1896	11	ATD, AXR	11/01→06/05	<b>UC14A</b>
1.9 TDI 4motion	4	74	1896	11	ATD	09/00→10/01	<b>UC31A</b>
1.9 TDI 4motion	4	74	1896	11	ATD	11/01→06/05	<b>UC14A</b>
1.9 TDI	4	81	1896	11	AHF, ASV	08/97→05/04	<b>UC31A</b>
1.9 TDI	4	85	1896	11	AJM, AUJ	12/98→06/01	<b>UC31A</b>
1.9 TDI 4motion	4	85	1896	11	AJM, AUJ	09/99→06/01	<b>UC31A</b>
1.9 TDI	4	96	1896	11	ASZ	11/00→10/01	<b>UC31A</b>
1.9 TDI	4	96	1896	11	ASZ	11/01→06/05	<b>UC14A</b>
1.9 TDI 4motion	4	96	1896	11	ASZ	11/00→10/01	<b>UC31A</b>
1.9 TDI 4motion	4	96	1896	11	ASZ	11/01→06/05	<b>UC14A</b>
1.9 TDI	4	110	1896	11	ARL	05/00→10/01	<b>UC31A</b>
1.9 TDI	4	110	1896	11	ARL	11/01→06/05	<b>UC14A</b>
1.9 TDI 4motion	4	110	1896	11	ARL	02/00→10/01	<b>UC31A</b>
1.9 TDI 4motion	4	110	1896	11	ARL	11/01→06/05	<b>UC14A</b>

**GOLF V**

1.9 TDI	4	66	1896	5	BRU, BXF, BXJ 70251®	05/04→	<b>UC01F</b>
1.9 TDI	4	66	1896	5	BRU, BXF, BXJ	05/05→	<b>UC01F</b>
1.9 TDI	4	77	1896	5	BKC, BLS, BXE 70251®	10/03→	<b>UC01F</b>
1.9 TDI 4motion	4	77	1896	5	BKC, BLS, BXE 70251®	08/04→	<b>UC01F</b>
2.0 SDI	4	55	1968	4,4	BDK	01/04→	<b>UC03F</b>
2.0 TDI	4	100	1968	4,4	AZV, CBDA	10/03→	<b>UC03F</b>
2.0 TDI 16V	4	103	1968	4,4	BKD	10/03→	<b>UC03F</b>
2.0 TDI 16V 4motion	4	103	1968	4,4	BKD, CBDB	08/04→	<b>UC03F</b>
2.0 TDI	4	125	1968	4,4	BMN	11/05→	<b>UC03F</b>

**JETTA III**

1.9 TDI	4	77	1896	5	BKC, BLS, BXE	08/05→	<b>UC01F</b>
2.0 TDI 16V	4	103	1968	4,4	CBEA	08/05→	<b>UC03F</b>

**LUPO**

1.2 TDI 3L	3	45	1191	11	ANY, AYZ	07/99→10/01	<b>UC31A</b>
1.2 TDI 3L	3	45	1191	11	ANY, AYZ	11/01→07/05	<b>UC14A</b>
1.4 TDI	3	55	1422	11	AMF	01/99→10/01	<b>UC31A</b>
1.4 TDI	3	55	1422	11	AMF	11/01→07/05	<b>UC14A</b>
1.7 SDI	4	44	1716	11	AKU	09/98→07/05	<b>UC31A</b>



**VOLKSWAGEN**
**MULTIVAN V**

1.9 TDI	4	77	1896	11	AXB	04/03→	<b>UC14A</b>
2.5 TDI	5	96	2461	11	AXD, BNZ	04/03→	<b>UC14A</b>
2.5 TDI 4motion	5	96	2461	11	AXD, BNZ	07/04→	<b>UC14A</b>
2.5 TDI	5	128	2461	11	AXE, BPC	04/03→	<b>UC14A</b>
2.5 TDI 4motion	5	128	2461	11	AXE, BPC	07/04→	<b>UC14A</b>

**NEW BEETLE**

1.9 TDI	4	66	1896	11	ALH	01/98→06/04	<b>UC31A</b>
1.9 TDI	4	74	1896	11	ATD, BEW	02/01→10/01	<b>UC31A</b>
1.9 TDI	4	74	1896	11	ATD, BEW	11/01→	<b>UC14A</b>
1.9 TDI	4	77	1896	5	BSW	07/05→	<b>UC01F</b>

**PASSAT**

1.6 TD	4	59	1588	11	RA, SB	08/88→09/93	<b>UX25A</b>
1.9 TD	4	55	1896	11	AAZ	03/91→05/97	<b>UX25A</b>
1.9 D 8V	4	50	1896	11	1Y	05/89→10/93	<b>UX8A</b>
1.9 TD 8V	4	55	1896	11	AAZ	03/91→08/96	<b>UX8A</b>
1.9 TDI	4	66	1896	11	1Z, AHH, AHU	10/93→11/00	<b>UC31A</b>
1.9 TDI	4	74	1896	11	AVB	02/00→10/01	<b>UC31A</b>
1.9 TDI	4	74	1896	11	AVB	11/01→	<b>UC14A</b>
1.9 TDI	4	77	1896	5	BKC, BLS, BXE	03/05→	<b>UC01F</b>
1.9 TDI	4	81	1896	11	AFN	03/96→08/96	<b>UC31A</b>
1.9 TDI	4	81	1896	11	AFN, AVG	10/96→11/00	<b>UC31A</b>
1.9 TDI Syncro/4motion	4	81	1896	11	AFN, AVG	10/96→11/00	<b>UC31A</b>
1.9 TDI	4	85	1896	11	AJM, ATJ	08/98→11/00	<b>UC31A</b>
1.9 TDI 4motion	4	85	1896	11	AJM, ATJ	08/99→11/00	<b>UC31A</b>
1.9 TDI	4	96	1896	11	AVF, AWX	11/00→10/01	<b>UC31A</b>
1.9 TDI	4	96	1896	11	AVF, AWX	11/01→05/05	<b>UC14A</b>
1.9 TDI 4motion	4	96	1896	11	AVF	11/00→10/01	<b>UC31A</b>
1.9 TDI 4motion	4	96	1896	11	AVF	11/01→05/05	<b>UC14A</b>
2.0 TDI	4	90	1968	4,4	BVD, BVE	08/05→	<b>UC03F</b>
2.0 TDI	4	100	1968	4,4	BGH, BGW, BHW	12/03→05/05	<b>UC03F</b>
2.0 TDI	4	100	1968	4,4	BMA, CBAA	08/05→	<b>UC03F</b>
2.0 TDI 16V	4	103	1968	4,4	BKP, CBAB	03/05→	<b>UC03F</b>
2.0 TDI	4	125	1968	4,4	BMR	08/05→	<b>UC03F</b>
2.5 TDI	6	110	2496	11	AFB, AKN	07/98→11/00	<b>UC45A</b>
2.5 TDI Syncro/4motion	6	110	2496	11	AFB, AKN	12/98→11/00	<b>UC45A</b>
2.5 TDI	6	110	2496	11	AFB, AKN	11/00→05/05	<b>UC45A</b>
2.5 TDI 4motion	6	110	2496	11	AFB, AKN	11/00→05/05	<b>UC45A</b>
2.5 TDI	6	120	2496	11	BDG	05/03→05/05	<b>UC45A</b>



### VOLKSWAGEN

2.5 TDI 4motion	6	132	2496	11	BAU, BDH	01/03→05/05	UC45A
-----------------	---	-----	------	----	----------	-------------	-------

### PHAETON

3.0 V6 TDI 4motion	6	165	2967	4,4	BMK	09/04→	UY7A
--------------------	---	-----	------	-----	-----	--------	------

5.0 V10 TDI 4motion	10	230	4921	11	AJS	11/02→	UC14A
---------------------	----	-----	------	----	-----	--------	-------

### POLO

1.4 D 8V	4	35	1398	11	1W	10/90→09/94	UX8A
----------	---	----	------	----	----	-------------	------

1.4 D	4	35	1398	11	1W	08/90→09/94	UX25A
-------	---	----	------	----	----	-------------	-------

1.4 TDI	3	51	1422	11	BNM, BWB	04/05→	UC14A
---------	---	----	------	----	----------	--------	-------

1.4 TDI	3	55	1422	11	AMF	10/99→09/01	UC31A
---------	---	----	------	----	-----	-------------	-------

1.4 TDI	3	55	1422	11	AMF, BAY	10/01→06/05	UC14A
---------	---	----	------	----	----------	-------------	-------

1.4 TDI	3	55	1422	11	BAY	07/03→	UC14A
---------	---	----	------	----	-----	--------	-------

1.4 TDI	3	59	1422	11	BMS, BNV	04/05→	UC14A
---------	---	----	------	----	----------	--------	-------

1.7 SDI	4	42	1716	11	AHG	04/97→10/99	UC31A
---------	---	----	------	----	-----	-------------	-------

1.7 SDI	4	42	1716	11	AKW	08/97→09/01	UC31A
---------	---	----	------	----	-----	-------------	-------

60 1.7 SDI	4	44	1716	11	AKU	08/97→10/99	UC31A
------------	---	----	------	----	-----	-------------	-------

1.7 SDI	4	44	1716	11	AKU	10/99→09/01	UC31A
---------	---	----	------	----	-----	-------------	-------

64 1.9 D	4	47	1896	11	AEF	10/94→10/99	UX25A
----------	---	----	------	----	-----	-------------	-------

64 1.9 SDI	4	47	1896	11	AGD	07/96→10/99	UC31A
------------	---	----	------	----	-----	-------------	-------

1.9 SDI	4	47	1896	11	AEY	06/97→09/01	UC31A
---------	---	----	------	----	-----	-------------	-------

1.9 D 8V	4	47	1896	11	AEF	10/94→10/99	UX8A
----------	---	----	------	----	-----	-------------	------

1.9 D	4	47	1896	11	AEF	10/99→09/01	UX25A
-------	---	----	------	----	-----	-------------	-------

1.9 SDI	4	47	1896	11	AGD, ASX	10/99→09/01	UC31A
---------	---	----	------	----	----------	-------------	-------

1.9 SDI	4	47	1896	11	ASY	10/01→	UC31A
---------	---	----	------	----	-----	--------	-------

1.9 SDI	4	47	1896	11	ASY	09/02→	UC31A
---------	---	----	------	----	-----	--------	-------

1.9 SDI	4	50	1896	11	AGP, AQM	08/99→09/01	UC31A
---------	---	----	------	----	----------	-------------	-------

1.9 TDI	4	66	1896	11	AGR, AHU, ALE, ALH	05/97→09/01	UC31A
---------	---	----	------	----	--------------------	-------------	-------

1.9 TDI	4	74	1896	11	ATD, AXR, BMT	10/01→	UC14A
---------	---	----	------	----	---------------	--------	-------

1.9 TDI	4	81	1896	11	AFN, ASV	06/98→09/01	UC31A
---------	---	----	------	----	----------	-------------	-------

1.9 TDI	4	96	1896	5	ASZ, BLT 70251®	11/03→	UC01F
---------	---	----	------	---	-----------------	--------	-------

### SHARAN

1.9 TDI	4	66	1896	11	1Z, AHU, ANU	09/95→10/01	UC31A
---------	---	----	------	----	--------------	-------------	-------

1.9 TDI	4	66	1896	11	1Z, AHU, ANU	11/01→	UC14A
---------	---	----	------	----	--------------	--------	-------

1.9 TDI	4	81	1896	11	AFN, AVG	09/96→04/00	UC31A
---------	---	----	------	----	----------	-------------	-------

1.9 TDI	4	85	1896	11	AUY, BVK	04/00→10/01	UC31A
---------	---	----	------	----	----------	-------------	-------

1.9 TDI 4motion	4	85	1896	11	AUY, BVK	04/00→10/01	UC31A
-----------------	---	----	------	----	----------	-------------	-------

1.9 TDI	4	85	1896	11	AUY, BVK	11/01→	UC14A
---------	---	----	------	----	----------	--------	-------

1.9 TDI 4motion	4	85	1896	11	AUY, BVK	11/01→	UC14A
-----------------	---	----	------	----	----------	--------	-------

1.9 TDI	4	96	1896	11	ASZ	11/02→	UC14A
---------	---	----	------	----	-----	--------	-------

1.9 TDI	4	110	1896	5	BTB	06/05→	UC01F
---------	---	-----	------	---	-----	--------	-------

**VOLKSWAGEN**

<b>TOUAREG</b>							
2.5 R5 TDI	5	128	2461	11	BAC, BPE	01/03→	<b>UC14A</b>
3.0 V6 TDI	6	165	2967	4,4	BKS	11/04→	<b>UY7A</b>
5.0 V10 TDI	10	230	4921	11	AYH, BLE, BWF	10/02→	<b>UC14A</b>
<b>TOURAN</b>							
1.9 TDI	4	66	1896	5	BRU, BXJ	11/04→	<b>UC01F</b>
1.9 TDI	4	74	1896	11	AVQ	02/03→	<b>UC14A</b>
1.9 TDI	4	77	1896	5	BKC, BXE	08/03→	<b>UC01F</b>
2.0 TDI	4	100	1968	4,4	AZV	02/03→	<b>UC03F</b>
2.0 TDI 16V	4	103	1968	4,4	BKD	08/03→	<b>UC03F</b>
<b>VENTO</b>							
1.9 SDI	4	47	1896	11	AEY	04/97→09/98	<b>UC31A</b>
1.9 D 8V	4	48	1896	11	1Y	11/91→09/98	<b>UX8A</b>
1.9 D	4	48	1896	11	1Y	11/91→09/98	<b>UX25A</b>
1.9 TD 8V	4	55	1896	11	AAZ	11/91→09/98	<b>UX8A</b>
1.9 TD	4	55	1896	11	AAZ	11/91→09/98	<b>UX25A</b>
1.9 TDI	4	66	1896	11	1Z, AHU, ALE	09/93→09/98	<b>UC31A</b>
1.9 TDI	4	66	1896	11	AFN	04/96→09/98	<b>UC31A</b>
<b>CADDY</b>							
1.6 D 8V	4	40	1588	11	JK/ME	08/82→07/92	<b>UX8A</b>
1.7 SDI	4	42	1716	11	AHB	07/96→09/00	<b>UC31A</b>
1.9 D 8V	4	47	1896	11	1Y, AEF	11/95→01/04	<b>UX8A</b>
1.9 D	4	47	1896	11	1Y	11/95→01/04	<b>UX25A</b>
1.9 SDI	4	47	1896	11	AEY,	11/95→01/04	<b>UC31A</b>
1.9 TDI	4	66	1896	11	AEY,	09/96→01/04	<b>UC31A</b>
1.9 TDI	4	66	1896	11	AHU, ALE, ALH	10/96→01/04	<b>UC31A</b>
1.9 TDI	4	77	1896	5	BJB, BLS 70251®	04/04→	<b>UC01F</b>
1.9 TDI	4	55	1896	5	BSU	09/05→	<b>UC01F</b>
2.0 SDI	4	51	1968	4,4	BDJ, BST	03/04→	<b>UC03F</b>
<b>CALIFORNIA</b>							
1.9 D 8V	4	44		11	1X	09/90→07/95	<b>UX8A</b>
1.9 TD 8V	4	50		11	ABL	08/92→03/98	<b>UX8A</b>
2.4 D 10V	5	57		11	AAB, AJA	09/90→04/98	<b>UX8A</b>
<b>CARAVELLE</b>							
1.9 D 8V	4			11		09/90→04/96	<b>UX8A</b>
2.4 D 10V	5			11		09/90→07/95	<b>UX8A</b>
<b>EUROVAN</b>							
2.4 SDi 10V	5	57		11		10/92→	<b>UX8A</b>



## VOLKSWAGEN

### LT II

2.5 SDI	5	55	2461	11	AGX	07/96→	UC31A
2.5 TDI	5	61	2461	11	BBE	05/01→	UC31A
2.5 TDI	5	66	2461	11	APA	05/99→	UC31A
2.5 TDI	5	70	2461	11	BBF	05/01→	UC31A
2.5 TDI	5	75	2461	11	AHD	05/96→08/99	UC31A
2.5 TDI Front Wheel Drive	5	80	2461	11	ANJ, AVR	05/99→	UC31A
2.8 TDI	4	96	2799	11	ATA	01/99→	UC31A
2.8 TDI	4	116	2799	11	AUH, BCQ	04/02→	UC42A

### MULTIVAN

1.9 D 8V	4	44		11	1X	09/90→07/95	UX8A
1.9 D 8V	4	68		11	ABL	08/92→06/94	UX8A
1.9 TD 8V	4	50		11	ABL	07/94→04/98	UX8A
2.4 D 8V	4	57		11	AJA, AAB	09/90→04/98	UX8A

### TRANSPORTER IV

1.9 D	4	44	1896	11	1X	09/90→04/03	UX25A
1.9 D 8V	4	45	1896	11	1X	07/90→	UX8A
1.9 D	4	45	1896	11	1X	07/90→04/03	UX25A
1.9 TD 8V	4	50	1896	11	ABL	10/92→	UX8A
1.9 TD	4	50	1896	11	ABL	10/92→04/03	UX25A
1.9 TDI	4	63	1896	11	AXC	04/03→	UC14A
1.9 TDI	4	77	1896	11	AXB	04/03→	UC14A
2.4 D 10V	5	55	2370	11	AJA	08/97→	UX8A
2.4 D	5	55	2370	11	AJA	08/97→04/03	UX25A
2.4 D 10V	5	57	2370	11	AAB	07/90→	UX8A
2.4 D	5	57	2370	11	AAB	07/90→04/98	UX25A
2.4 D 10V Syncro	5	57	2370	11	AAB	10/92→	UX8A
2.4 D Syncro	5	57	2370	11	AAB	10/92→09/98	UX25A
2.5 TDI	5	65	2461	11	AJT	12/98→04/03	UC31A
2.5 TDI	5	65	2461	11	AYY	10/01→04/03	UC14A
2.5 TDI	5	75	2461	11	ACV, AUF, AYC	09/95→04/03	UC31A
2.5 TDI Syncro	5	75	2461	11	ACV, AXL	09/95→04/03	UC31A
2.5 TDI	5	96	2461	11	AXD, BNZ	04/03→	UC14A
2.5 TDI 4motion	5	96	2461	11	AXD, BNZ	07/04→	UC14A
2.5 TDI	5	111	2461	11	AXG	05/98→04/03	UC14A
2.5 TDI	5	111	2461	11	AHY, AXG	09/00→04/03	UC31A
2.5 TDI	5	128	2461	11	AXE, BPC	04/03→	UC14A
2.5 TDI 4motion	5	128	2461	11	AXE, BPC	07/04→	UC14A



<b>VOLVO</b>							
<b>440</b>							
1.9 TD 8V	4	66	1870	11	D 19 T	07/94→12/96	<b>UX18A</b>
<b>460</b>							
1.9 TD 8V	4	66	1870	11	D 19 T	07/94→07/96	<b>UX18A</b>
<b>850</b>							
2.5 TDI	5	103	2461	11	D 5252 T	08/95→12/96	<b>UC31A</b>
<b>940</b>							
2.4 D 12V	6	60	2383	11	D 24	08/90→12/94	<b>UX8A</b>
2.4 D	6	60	2383	11	D 24	08/90→07/95	<b>UX25A</b>
2.4 TD 12V	6	80	2383	11	D 24 T	08/90→12/94	<b>UX8A</b>
2.4 Turbo Diesel	6	80	2383	11	D 24 T	08/90→12/94	<b>UX25A</b>
2.4 TD 12V Intercooler	6	90	2383	11	D 24 TIC	08/90→10/98	<b>UX8A</b>
2.4 TD Intercooler	6	90	2383	11	D 24 TIC	08/90→10/98	<b>UX25A</b>
<b>960</b>							
2.4 TD 12V Intercooler	6	85	2383	11	D 24 TIC	09/91→07/94	<b>UX8A</b>
2.4 TD Interc.	6	85	2383	11	D 24 TIC	09/91→07/94	<b>UX25A</b>
<b>S40</b>							
1.6 D	4	81	1560	11	D 4164 T	01/05→	<b>UY1A</b>
1.9 TD 8V	4	66	1870	11	D 4192 T	07/95→08.99	<b>UX18A</b>
1.9 DI	4	75	1870	11	D 4192 T4	07/00→12/03	<b>UC19A</b>
1.9 DI	4	85	1870	11	D 4192 T3	07/00→12/03	<b>UC19A</b>
2.0 D 16V	4	100	1998	11	D 4204 T	01/04→	<b>UC41A</b>
<b>S60</b>							
2.4 D	5	96	2401	11	D 5244 T2	12/01→	<b>UY4A</b>
2.4 D5	5	120	2401	11	D 5244 T	07/01→	<b>UY4A</b>
2.5 TDI	5	103	2461	11	D 5252 T	10/01→	<b>UC31A</b>
<b>S70</b>							
2.5 TDI	5	103	2461	11	D 5252 T	01/97→11/00	<b>UC31A</b>
<b>S80</b>							
2.4 D	5	96	2401	11	D 5244 T2	10/01→07/06	<b>UY4A</b>
2.4 D5	5	120	2401	11	D 5244 T	08/01→07/06	<b>UY4A</b>
2.5 TDI	5	103	2461	11	D 5252 T	01/99→07/06	<b>UC31A</b>
<b>V40</b>							
1.9 TD 8V	4	66	1870	11	D 4192 T	07/95→08/99	<b>UX18A</b>
1.9 TD 8V	4	70	1870	11	D 4192 T2	03/99→07/00	<b>UX18A</b>
1.9 DI	4	75	1870	11	D 4192 T4	07/00→06/04	<b>UC19A</b>
1.9 DI	4	85	1870	11	D 4192 T3	07/00→06/04	<b>UC19A</b>

**kW**
**cc**
**V**

**MAGNETI MARELLI**
**VOLVO**
**V50**

1.6 D	4	81	1560	11	D 4164 T	01/05→	<b>UY1A</b>
2.0 D	4	100	1998	11	D 4204 T	04/04→	<b>UC41A</b>

**V70**

2.4 D	5	96	2401	11	D 5244 T2	12/01→	<b>UY4A</b>
2.4 D5	5	120	2401	11	D 5244 T	08/01→	<b>UY4A</b>
2.4 D5 AWD	5	120	2401	11	D 5244 T2	03/03→	<b>UY4A</b>
2.4 D5	5	136	2401	11	D 5244 T4	12/05→	<b>UY4A</b>
2.4 D5 AWD	5	136	2401	11	D 5244 T4	12/05→	<b>UY4A</b>
2.5 TDI	5	103	2461	11	D 5252 T	01/97→	<b>UC31A</b>

**XC70 CROSS COUNTRY**

2.4 D5 XC AWD	5	120	2401	11	D 5244 T	09/02→	<b>UY4A</b>
2.4 D5 AWD	5	136	2401	11	D 5244 T4	12/05→	<b>UY4A</b>

**XC 90**

D5	5	120	2401	11	D 5244 T	10/02→	<b>UY4A</b>
----	---	-----	------	----	----------	--------	-------------

*Applicazione per codice*  
*Buyers guide*  
*Zuordnung nach Bestellnummer*  
*Affectations par références*  
*Aplicación por código*  
*Aplicação por código*  
*Εφαρμογες ανα κωδικο*  
*Zastosowanie dla kodu*  
*Применение для кода*  
*Şifreye göre uygulama*

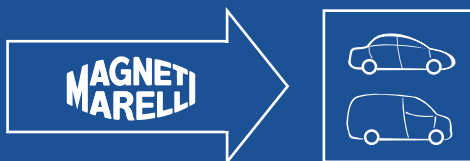

# UC01F

062900038304

ULTRA FAST

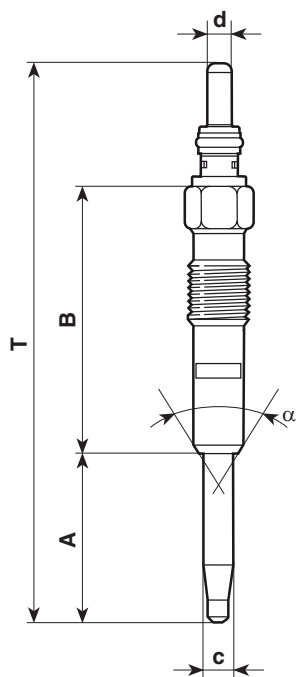

T	96
A	29
B	46
c	5
d	4
$\alpha$	63°
	M10X1
	10
V	5
Amp	-
	1,5"
Nm	10÷12



<b>BERU</b>	010026600 GE100
<b>BOSCH</b>	0250312001 0250402001
<b>CHAMPION</b>	CH700
<b>NGK</b>	CY51 CZ101



## AUDI

### A2

1.4 TDI	3	55	1422	5	AMF, BHC	09/03a
1.4 TDI	3	66	1422	5	ATL	11/03→08/05

### A3

1.9 TDI	4	77	1896	5	BKC	05/03→
---------	---	----	------	---	-----	--------

### A3 Sportback

1.9 TDI	4	77	1896	5	BKC	09/04→
---------	---	----	------	---	-----	--------

### A4

1.9 TDI	4	85	1896	5	BKE	06/04→12/04
1.9 TDI	4	85	1896	5	BKE, BRB	11/04→

### A4 Avant

1.9 TDI	4	85	1896	5	BKE	06/04→12/04
1.9 TDI	4	85	1896	5	BKE, BRB	11/04→

## SEAT

### ALHAMBRA

1.9 TDI	4	110	1896	5	ARL, BTB	05/05→
---------	---	-----	------	---	----------	--------



**SEAT****ALTEA**

1.9 TDI	4	77	1896	5	BJB, BKC, BLS, BXE	04/04→
---------	---	----	------	---	--------------------	--------

**IBIZA IV**

1.9 TDI Cupra R	4	118	1896	5	BPX, BUK	03/04→
-----------------	---	-----	------	---	----------	--------

**LEON**

1.9 TDI	4	74	1896	5	AXR	10/05→
---------	---	----	------	---	-----	--------

1.9 TDI	4	77	1896	5	BKC, BLS, BXE	09/05→
---------	---	----	------	---	---------------	--------

**TOLEDO III**

1.9 TDI	4	77	1896	5	BJB, BKC, BLS, BXE	10/04→
---------	---	----	------	---	--------------------	--------

**SKODA****OCTAVIA**

1.9 TDI	4	77	1896	5	BJB, BKC 70251→	06/04→
---------	---	----	------	---	-----------------	--------

1.9 TDI 4x4	4	77	1896	5	BKC 70251→	11/04→
-------------	---	----	------	---	------------	--------

**ROOMSTER**

1.9 TDI	4	77	1896	5	BLS, BSW	09/06→
---------	---	----	------	---	----------	--------

**VOLKSWAGEN****GOLF V**

1.9 TDI	4	66	1896	5	BRU, BXF, BXJ 70251→	05/04→
---------	---	----	------	---	----------------------	--------

1.9 TDI	4	66	1896	5	BRU, BXF, BXJ	05/05→
---------	---	----	------	---	---------------	--------

1.9 TDI	4	77	1896	5	BKC, BLS, BXE 70251→	10/03→
---------	---	----	------	---	----------------------	--------

1.9 TDI 4motion	4	77	1896	5	BKC, BLS, BXE 70251→	08/04→
-----------------	---	----	------	---	----------------------	--------

**JETTA III**

1.9 TDI	4	77	1896	5	BKC, BLS, BXE	08/05→
---------	---	----	------	---	---------------	--------

**NEW BEETLE**

1.9 TDI	4	77	1896	5	BSW	07/05→
---------	---	----	------	---	-----	--------

**PASSAT**

1.9 TDI	4	77	1896	5	BKC, BLS, BXE	03/05→
---------	---	----	------	---	---------------	--------

**POLO**

1.9 TDI	4	96	1896	5	ASZ, BLT 70251→	11/03→
---------	---	----	------	---	-----------------	--------

**SHARAN**

1.9 TDI	4	110	1896	5	BTB	06/05→
---------	---	-----	------	---	-----	--------

**TOURAN**

1.9 TDI	4	66	1896	5	BRU, BXJ	11/04→
---------	---	----	------	---	----------	--------

1.9 TDI	4	77	1896	5	BKC, BXE	08/03→
---------	---	----	------	---	----------	--------

**CADDY**

1.9 TDI	4	77	1896	5	BJB, BLS 70251→	04/04→
---------	---	----	------	---	-----------------	--------

1.9 TDI	4	55	1896	5	BSU	09/05→
---------	---	----	------	---	-----	--------

# UC02F

062900039304

ULTRA FAST

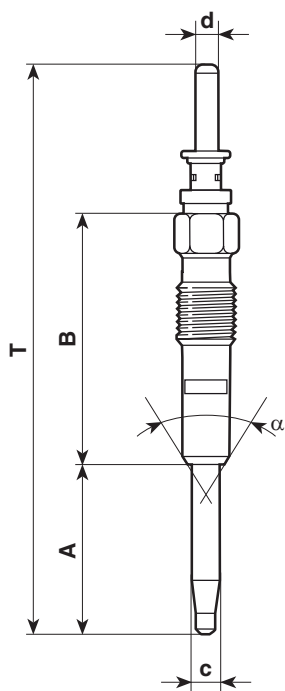

T	105
A	31,6
B	46
c	5
d	4
$\alpha$	63°
	M10X1
	10
V	5
Amp	-
	1,5''
Nm	10÷12



<b>BERU</b>	GE102
<b>BOSCH</b>	0250402002
<b>CHAMPION</b>	CH701
<b>NGK</b>	Y547AS



## AUDI

### A4 Convertible

2.0 TDI	4	103	1968	5	BPW	01/06→
---------	---	-----	------	---	-----	--------

## BMW

### 1 (E87)

118d	4	90	1995	5	M47N204D4	09/04→
120d	4	120	1995	5	M47N204D4, N47D204	09/04→

### 3 (E46)

318d	4	85	1951	5	M47204D1	09/01→03/03
318d	4	85	1995	5	M47N204D4	03/03→02/05
320d	4	110	1995	5	M47N204D4	09/01→02/05
330d	6	150	2993	5	M57N306D2	03/03→02/05
330xd	6	150	2993	5	M57N306D2	03/03→02/05

### 3 Compact (E46)

318td	4	85	1995	5	M47N204D4	03/03→02/05
320td	4	110	1995	5	M47N204D4	09/01→02/05

**BMW****3 Convertible (E46)**

320Cd	4	110	1995	5	M47N204D4	02/05→
330Cd	6	150	2993	5	M57N306D2	08/05→

**3 Coupe (E46)**

320Cd	4	110	1995	5	M47N204D4	11/03→
330Cd	6	150	2993	5	M57N306D2	03/03→

**3 Touring (E46)**

318d	4	85	1951	5	M47204D1, M47D20	03/02→02/05
318d	4	85	1995	5	M47N204D4	03/03→02/05
320d	4	110	1995	5	M47N204D4	09/01→02/05
330d	6	150	2993	5	M57N306D2	03/03→02/05
330xd	6	150	2993	5	M57N306D2	03/03→02/05

**3 (E90)**

318d	4	90	1995	5		09/05→
320d	4	120	1995	5	M47N204D4, M47N204D5	01/05→
325d	6	145	2993	5	M57306D3	09/06→
330d	6	170	2993	5		09/05→
330xd	6	170	2993	5		09/05→

**3 Touring (E91)**

318d	4	90	1995	5		09/05→
320d	4	110	1995	5	M47D20TU, M47N204D4	09/05→
320d	4	120	1995	5	M47N204D5, N47D20A	09/05→
325d	6	145	2993	5	M57 TU2 D30, M57306D3	09/06→
330d	6	170	2993	5	M57306D3	09/05→
330xd	6	170	2993	5	M57 TU2 D30, M57306D3	09/05→

**3 Coupe (E92)**





325d	6	145	2993	5	M57 TU2 D30, N57N306D3	03/07→
------	---	-----	------	---	------------------------	--------

**5 (E60)**

520d	4	120	1995	5	M47N204D5, N47D20A	07/05→
525d	6	130	2497	5	M 57 D 25 TU, M57N256D4	06/04→
530d	6	160	2993	5	N57306D2	07/03→
530d	6	170	2993	5	M57306D3	07/03→
530xd	6	170	2993	5	M57306D3	07/05→
535d	6	200	2993	5	M57306D4	09/04→

**5 Touring (E61)**

520d	4	120	1995	5	M47N204D5, N47D20A	07/05→
525d	6	130	2497	5	M 57 D 25 TU, M57N256D4	06/04→
530d	6	160	2993	5	N57306D2	06/04→
530d	6	170	2993	5	M57306D3	07/05→

  	<b>kW</b>	<b>cc</b>	<b>V</b>			
<b>BMW</b>						
530xd	6	170	2993	5	M57306D3	07/05→
535d	6	200	2993	5	M57306D4	09/04→
<b>7 (E65, E66)</b>						
730 d	6	160	2993	5	N57306D2	10/02→
730 Ld	6	170	2993	5	M57306D3, N57N306D2	07/05→
<b>X3 (E83)</b>						
2.0 d	4	110	1995	5	M47N204D4	10/04→
3.0 d	6	150	2993	5	M54N306D2	01/04→
3.0 d	6	160	2993	5	M57N2306D2	01/04→
3.0 sd	6	210	2993	5	N57N306D5	09/06→
<b>X5 (E53)</b>						
3.0 d	6	160	2993	5	M57N306D4	12/03→
<b>X5 (E70)</b>						
3.0 sd	6	210	2993	5	M57N306D5	09/07→

# UC03F

## 062900051304



ULTRA FAST

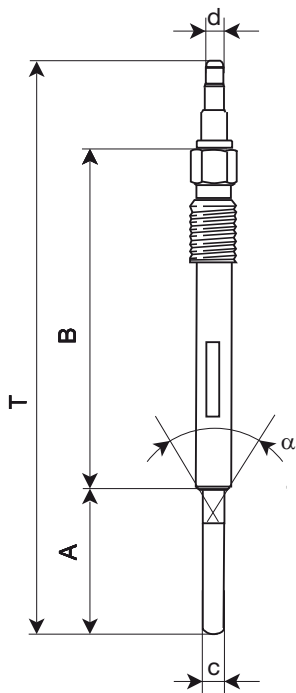

T	117,6
A	29,6
B	70
c	4
d	4
$\alpha$	93°
	M8X1
	8
V	4,4
Amp	8,5
	1,5"
Nm	8÷10

<b>BERU</b>	0100266009
<b>BOSCH</b>	0250403002
<b>CHAMPION</b>	CH702



### AUDI

#### A3

2.0 TDI	4	100	1968	4,4	AZV	05/03→
2.0 TDI quattro	4	100	1968	4,4	AZV	05/03→
2.0 TDI 16V	4	103	1968	4,4	BKD, BMM	05/03→
2.0 TDI 16V quattro	4	103	1968	4,4	BKD, BMM	08/04→

#### A3 Sportback

2.0 TDI	4	100	1968	4,4	AZV	09/04→
2.0 TDI 16V	4	103	1968	4,4	BKD, BMM	09/04→
2.0 TDI 16V quattro	4	103	1968	4,4	BMM	11/05→

#### A4

2.0 TDI	4	100	1968	4,4	BNA	11/04→
2.0 TDI 16V	4	103	1968	4,4	BLB, BPW	11/04→

#### A4 Avant

2.0 TDI 16V	4	103	1968	4,4	BLB, BRE	11/04→
-------------	---	-----	------	-----	----------	--------

#### A6

2.0 TDI	4	100	1968	4,4	BNA, BRF	06/05→
2.0 TDI	4	103	1968	4,4	BLB, BRE	07/04→

			<b>kW</b>	<b>cc</b>	<b>V</b>		
--	--	--	-----------	-----------	----------	--	--

## AUDI

### A6 Avant

2.0 TDI	4	100	1968	4,4	BNA, BRF, CAGB	06/05→
2.0 TDI	4	103	1968	4,4	BLB, BRE	06/05→

## DODGE

### AVENGER

2.0 CRD	4	103	1968	4,4	ECD	06/07→
---------	---	-----	------	-----	-----	--------

### CALIBER

2.0 CRD	4	103	1968	4,4	ECD	06/06→
---------	---	-----	------	-----	-----	--------

## JEEP

### COMPASS

2.0 CRD	4	103	1968	4,4		09/06→
2.0 CRD 4x4	4	103	1968	4,4		09/06→

### PATRIOT

2.0 TD	4	103	1968	4,4		01/08→
--------	---	-----	------	-----	--	--------

## MITSUBISHI

### OUTLANDER

2.0 DI-D	4	103	1968	4,4	BSY	02/07→
----------	---	-----	------	-----	-----	--------

## SEAT

### ALTEA

2.0 TDI	4	100	1968	4,4	AZV	03/04→
2.0 TDI 16V	4	103	1968	4,4	BKD	03/04→

### LEON

2.0 TDI 16V	4	103	1968	4,4	BKD	09/05→
-------------	---	-----	------	-----	-----	--------

### TOLEDO III

2.0 TDI 16V	4	103	1968	4,4	BKD	10/04→
-------------	---	-----	------	-----	-----	--------

## SKODA

### OCTAVIA

2.0 TDI 16V	4	103	1968	4,4	BKD	02/04→
-------------	---	-----	------	-----	-----	--------





## VOLKSWAGEN

### EOS

2.0 TDI	4	103	1968	4,4	BMM	06/06→
---------	---	-----	------	-----	-----	--------

### GOLF V

2.0 SDI	4	55	1968	4,4	BDK	01/04→
---------	---	----	------	-----	-----	--------

 		<b>kW</b>	<b>cc</b>	<b>V</b>		
<b>VOLKSWAGEN</b>						
2.0 TDI	4	100	1968	4,4	AZV, CBDA	10/03→
2.0 TDI 16V	4	103	1968	4,4	BKD	10/03→
2.0 TDI 16V 4motion	4	103	1968	4,4	BKD, CBDB	08/04→
2.0 TDI	4	125	1968	4,4	BMN	11/05→
<b>JETTA III</b>						
2.0 TDI 16V	4	103	1968	4,4	CBEA	08/05→
<b>PASSAT</b>						
2.0 TDI	4	90	1968	4,4	BVD, BVE	08/05→
2.0 TDI	4	100	1968	4,4	BGH, BGW, BHW	12/03→05/05
2.0 TDI	4	100	1968	4,4	BMA, CBAA	08/05→
2.0 TDI 16V	4	103	1968	4,4	BKP, CBAB	03/05→
2.0 TDI	4	125	1968	4,4	BMR	08/05→
<b>TOURAN</b>						
2.0 TDI	4	100	1968	4,4	AZV	02/03→
2.0 TDI 16V	4	103	1968	4,4	BKD	08/03→
<b>CADDY</b>						
2.0 SDI	4	51	1968	4,4	BDJ, BST	03/04→

**UC04F**

062900052304



ULTRA FAST

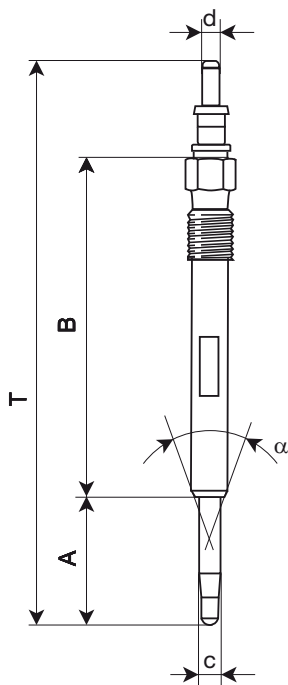

T	133
A	30
B	80
c	5
d	4
$\alpha$	63°
	M10X1
	10
V	5
Amp	9,2
	1,5"
Nm	10÷12

**CHAMPION** CH704



**kW**

**cc**

**V**



**MERCEDES-BENZ**

**C-CLASS (W203)**

C 30 CDI AMG	5	170	2950	5	OM 612.990	01/03→
--------------	---	-----	------	---	------------	--------

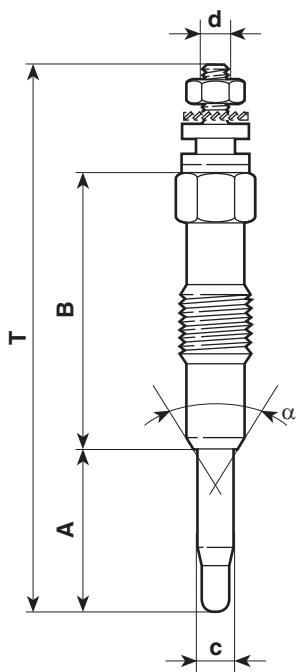

**UC2A**
**062581201304**

T	82
A	25
B	42
c	5
d	M4
$\alpha$	63°
	M10X1
	10
V	11,5
Amp	16
	7"
Nm	10÷15

<b>BERU</b>	GV730
<b>BOSCH</b>	0250202002
<b>CHAMPION</b>	CH90

**kW**
**cc**
**V**

**FIAT**
**CROMA (154)**

1900 Turbo D i.d.

4

69

1929

11

154 D1.000

11/92→12/96

# UC4A

062500300304

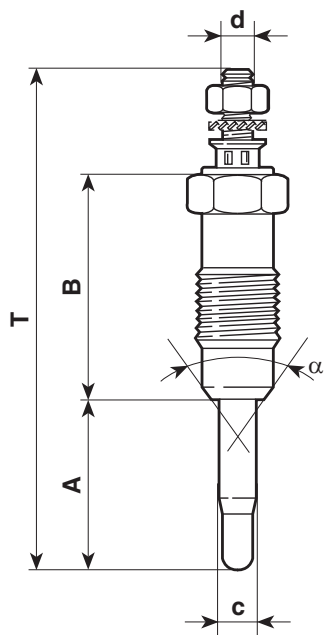

T	71
A	25
B	31,7
c	5
d	M4
$\alpha$	63°
	M12X1,25
	12
V	11
Amp	15
	7"
Nm	15÷20



<b>BERU</b>	0100226249 970MJ GN970
<b>BOSCH</b>	0250202034
<b>CHAMPION</b>	CH167
<b>NGK</b>	DP29 Y928U



## FIAT

### BRAVA

1.9 TD 75 S	4	55	1910	11	182 A8.000	03/96→10/01
1.9 TD 100 S	4	74	1910	11	182 A7.000	03/96→10/01

### BRAVO

1.9 TD 75 S	4	55	1910	11	182 A8.000	03/96→10/01
1.9 TD 100 S	4	74	1910	11	182 A7.000	03/96→10/01

### MAREA

1.9 TD 75	4	55	1910	11	182 A8.000	09/96→
1.9 TD 100	4	74	1910	11	182 A7.000	09/96→
2.4 TD 125	5	91	2387	11	185 A2.000	09/96→04/99

### MAREA Weekend

1.9 TD 75	4	55	1910	11	182 A8.000	09/96→
1.9 TD 100	4	74	1910	11	182 A7.000	09/96→
2.4 TD 125	5	91	2387	11	185 A2.000	09/96→04/99



**LANCIA**

**DELTA II**

1.9 TD	4	66	1929	11	160 D1.000, 835 A4.000	10/94→08/99
--------	---	----	------	----	------------------------	-------------

**KAPPA**

2.4 T.DS	5	91	2387	11	838 A3.000, 838 A7.000	08/94→10/01
----------	---	----	------	----	------------------------	-------------

**KAPPA SW**

2.4 T.DS	5	91	2387	11	838 A3.000, 838 A7.000	07/96→10/01
----------	---	----	------	----	------------------------	-------------

**TOYOTA**

**COROLLA**

2.0 D-4D	4	66	1995	11	1CD-FTV	08/02→
----------	---	----	------	----	---------	--------

# UC8A

062503901304

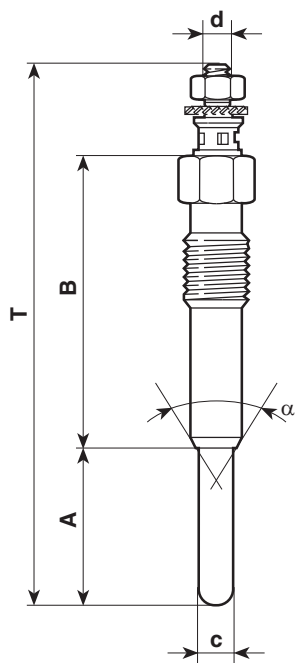

T	84
A	25
B	46
c	5
d	M4
$\alpha$	63°
	M10X1
	10
V	11
Amp	14,5
	5"
Nm	10÷15



<b>BERU</b>	0100226184 0100226238 905MJ 999MJ GN905 GN999
<b>BOSCH</b>	0250202025
<b>CHAMPION</b>	CH169
<b>NGK</b>	DP17 DP22 Y730U Y740 Y740U

			<b>kW</b>	<b>cc</b>	<b>V</b>		
--	--	--	-----------	-----------	----------	--	--

<b>FORD</b>							
<b>FOCUS</b>							
1.8 DI / TDDi	4	55	1753	11	BHDA, BHDB		08/99→11/04

<b>HONDA</b>							
<b>ACCORD VI</b>							
2.0 TDi	4	77	1994	11	20T2N		04/96→10/98
<b>ACCORD VII</b>							
2.0 Turbo DI	4	77	1994	11	20T2N		02/99→12/02
<b>CIVIC V</b>							
2.0 i TD	4	63	1994	11	20T2R		01/97→02/01
2.0 i D	4	77	1994	11	20T2N		04/98→02/01

<b>LAND ROVER</b>							
<b>FREELANDER</b>							
2.0 DI	4	72	1994	11			02/98→11/00

			<b>kW</b>	<b>cc</b>	<b>V</b>		
---	---	---	-----------	-----------	----------	---	---

**MG****ZR**

Turbodiesel	4	74	1994	11		06/01→
-------------	---	----	------	----	--	--------

**ZS**

2.0 TD	4	74	1994	11		01/04→
--------	---	----	------	----	--	--------

**RENAULT****ESPACE**

2.2 12V TD	4	83	2188	11	G8T 714, G8T 716, G8T 760	11/96→10/00
------------	---	----	------	----	---------------------------	-------------

**LAGUNA**

1.9 dTi	4	72	1870	11	F9Q 716	10/97→03/01
---------	---	----	------	----	---------	-------------

2.2 D	4	61	2188	11	G8T 706, G8T 752, G8T 790, G8T 794	11/93→03/01
-------	---	----	------	----	------------------------------------	-------------

2.2 dT	4	83	2188	11	G8T 760	03/96→03/01
--------	---	----	------	----	---------	-------------

**SAFRANE**

2.2 dT	4	83	2188	11	G8T 740	07/96→12/00
--------	---	----	------	----	---------	-------------

**SCENIC**

1.9 dTi	4	72	1870	11	F9Q 734	09/99→08/03
---------	---	----	------	----	---------	-------------

**ROVER****25**

2.0 iDT	4	74	1994	11	20 T2N	10/99→
---------	---	----	------	----	--------	--------

**45**

2.0 iDT	4	74	1994	11	20 T2N	02/00→
---------	---	----	------	----	--------	--------

**200**

220 D/SD	4	63	1994	11	20 T2R	11/95→03/00
----------	---	----	------	----	--------	-------------

220 SDi	4	77	1994	11	20 T2N	11/95→03/00
---------	---	----	------	----	--------	-------------

**400**

420 D	4	63	1994	11	20 T2R	11/95→03/00
-------	---	----	------	----	--------	-------------

420 Di	4	77	1994	11	20 T2N	05/95→03/00
--------	---	----	------	----	--------	-------------

**600**

620 Sdi	4	77	1994	11	20 T2N	12/94→02/99
---------	---	----	------	----	--------	-------------

**STREETWISE**

2.0 TD	4	74	1994	11	20 T2N	08/03→
--------	---	----	------	----	--------	--------

# UC9A

062583202304

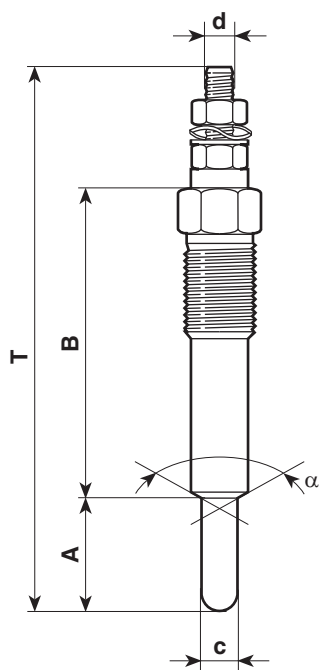

T	82
A	17
B	47
c	5
d	M4
$\alpha$	120°
	M10X1,25
	12
V	11
Amp	6
	8,5'
Nm	10÷15



<b>BERU</b>	0100226208 0100226209 947MJ GV947
<b>BOSCH</b>	0250202087
<b>CHAMPION</b>	CH158
<b>NGK</b>	DP28 Y711J Y711J Y711RS Y721RS Y743U



## ISUZU

### TROOPER

3.1 TD	4	84	3059	11	4 JG2 T	08/91→07/98
--------	---	----	------	----	---------	-------------

### MIDI Van

2.4 TD	4	56	2380	11	4FG1T	01/94→
--------	---	----	------	----	-------	--------

## OPEL

### ASTRA F

1.7 TDS	4	60	1686	11	17 DT (TC4EE1), X 17 DT (TC4EE1) → 956632	03/92→09/98
---------	---	----	------	----	--	-------------

### MONTEREY

3.1 TD (UBS69_)	4	84	3059	11	4 JG2TC	09/91→07/98
-----------------	---	----	------	----	---------	-------------

### CAMPO

3.1 TD	4	80	3059	11	4 JG2T	12/92→
--------	---	----	------	----	--------	--------

3.1 TD 4x4	4	80	3059	11	4 JG2T	12/92→
------------	---	----	------	----	--------	--------

			<b>kW</b>	<b>cc</b>	<b>V</b>		
---	---	---	-----------	-----------	----------	---	---

**VAUXHALL****ASTRA Mk III**

1.7 TD	4	50	1700	11	X 17 DTL 817253→	11/94→09/98
1.7 TD	4	60	1686	11	17 DT (TC4EE1) 817253→	12/91→09/98

**CAVALIER Mk III**

1.7 TD	4	60	1686	11	17 DT (TC4EE1) 817253→	09/88→11/95
--------	---	----	------	----	------------------------	-------------

**MONTEREY**

3.1 TD	4	84	3059	11	4 JG2TC	09/91→07/98
--------	---	----	------	----	---------	-------------

**NOVA**

1.5 TD	4	49	1488	11	15 DT (T4EC1)	01/90→02/93
--------	---	----	------	----	---------------	-------------

# UC10A

062583101304

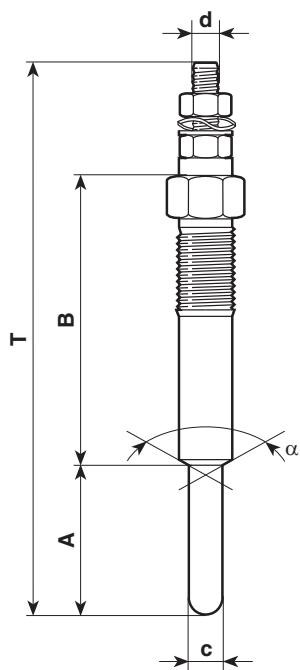

T	89
A	21
B	47
c	5
d	M4
$\alpha$	120°
	M10X1,25
	12
V	11
Amp	6
	8,5"
Nm	10÷15



<b>BERU</b>	0100226207 946MJ GV946
<b>BOSCH</b>	0250202085
<b>CHAMPION</b>	CH157
<b>NGK</b>	A14T Y710R Y742U



## OPEL

### CAMPO

2.2 D 4x4	4	39	2238	11	C223	08/91→09/96
-----------	---	----	------	----	------	-------------

## SSANGYONG

### KORANDO

2.2 D	4	50	2238	11	DC23	12/88→12/96
-------	---	----	------	----	------	-------------

## VAUXHALL

### NOVA

1.5 D	4	37	1488	11	15 D (4EC1) 804795→	09/87→02/93
-------	---	----	------	----	---------------------	-------------

### BRAVA

2.2 D	4	39	2238	11	C223	08/91→09/96
2.2 D 4x4	4	39	2238	11	C223	08/91→09/96

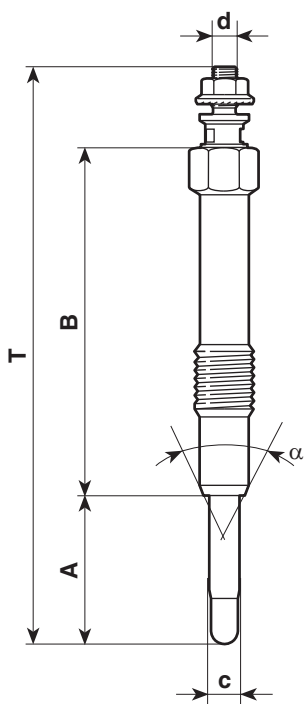

**UC11A**
**062900000304**

T	95
A	25
B	57
c	5
d	M4
$\alpha$	63°
	M10X1
	10
V	11
Amp	15
	4"
Nm	10÷15

<b>BERU</b>	GN017
<b>BOSCH</b>	0250202028 0250202033
<b>CHAMPION</b>	CH166
<b>NGK</b>	DP26 Y1032 Y747U

**ALFA ROMEO**
**145**

1.9 JTD	4	77	1910	11	AR 32302	02/99→10/99
---------	---	----	------	----	----------	-------------

**146**

1.9 JTD	4	77	1910	11	AR 32302	02/99→10/99
---------	---	----	------	----	----------	-------------

**156**

1.9 JTD	4	77	1910	11	AR 32302	09/97→10/00
2.4 JTD	5	100	2387	11	AR 32501	09/97→11/99

**156 Sportwagon**

1.9 JTD	4	77	1910	11	AR 32302	05/00→10/00
---------	---	----	------	----	----------	-------------

**166**

2.4 JTD	5	100	2387	11	AR 34202	09/98→10/00
---------	---	-----	------	----	----------	-------------

**FIAT**
**BRAVA**

1.9 JTD 105	4	77	1910	11	182 B4.000	12/98→10/99
-------------	---	----	------	----	------------	-------------

**BRAVO**

1.9 JTD 105	4	77	1910	11	182 B4.000	12/98→10/99
-------------	---	----	------	----	------------	-------------

			<b>kW</b>	<b>cc</b>	<b>V</b>		
--	---	---	-----------	-----------	----------	---	---

**FIAT**

**MAREA**

1.9 JTD 105	4	77	1910	11	182 B4.000	04/99→10/99
2.4 JTD 130	5	96	2387	11	185 A6.000, 839 A5.000	04/99→10/99

**MAREA Weekend**





1.9 JTD 105	4	77	1910	11	182 B4.000	04/99→10/99
2.4 JTD 130	5	96	2387	11	185 A6.000, 839 A5.000	04/99→10/99

**MULTIPLA**

1.9 JTD 105	4	77	1910	11	182 B4.000	04/99→10/99
-------------	---	----	------	----	------------	-------------

UC12A		062900001304			
	T	107,5	<b>BERU</b>	GN027	
	A	28	<b>BOSCH</b>	0250202032	
	B	64	<b>CHAMPION</b>	CH170	
	c	5	<b>NGK</b>	DP24 Y504J Y504R	
	d	M4			
	$\alpha$	63°			
		M10X1			
		10			
	V	11			
	Amp	15			
		4"			
	Nm	10÷15			

			kW	cc	V		
<b>CITROËN</b>							
<b>C4</b>							
2.0 HDi	4	100	1997	11	DW10BTED4, RHR (DW10BTED4)	11/04→	
<b>C4 Coupe</b>							
2.0 HDi	4	100	1997	11	DW10BTED4, RHR (DW10BTED4)	11/04→	
<b>C5</b>							
2.0 HDi	4	66	1997	11	RHY (DW10TD)	03/01→08/04	
2.0 HDi	4	80	1997	11	RHZ (DW10ATED)	03/01→08/04	
2.2 HDi	4	98	2179	11	4HX (DW12TED4/FAP)	03/01→08/04	
2.2 HDi	4	98	2179	11	4HX (DW12TED4/FAP)	09/04→	
<b>C5 Break</b>							
2.0 HDi	4	66	1997	11	RHY (DW10TD)	06/01→08/04	
2.0 HDi	4	79	1997	11	RHS (DW10ATED), RHZ (DW10ATED)	06/01→08/04	
2.2 HDi	4	98	2179	11	4HX (DW12TED4/FAP)	06/01→08/04	
2.2 HDi	4	98	2179	11	4HX (DW12TED4/FAP)	09/04→	
<b>C8</b>							
2.0 HDi	4	79	1997	11	RHM (DW10ATED4), RHT (DW10ATED4), RHW (DW10ATED4)	07/02→	

			<b>kW</b>	<b>cc</b>	<b>V</b>		
<b>CITROËN</b>							
2.2 HDi		4	94	2179	11	4HW (DW12TED4)	07/02→
<b>EVASION</b>							
2.0 HDi		4	80	1997	11	RHZ (DW10ATED)	08/99→07/02
<b>XANTIA</b>							
2.0 HDi 90		4	66	1997	11	RHY (DW10TD)	03/99→04/03
2.0 HDi 109		4	80	1997	11	RHZ (DW10ATED)	02/99→04/03
<b>XANTIA Break</b>							
2.0 HDi 90		4	66	1997	11	RHY (DW10TD)	03/99→04/03
2.0 HDi 109		4	80	1997	11	RHZ (DW10ATED)	02/99→04/03
<b>XSARA</b>							
2.0 HDi 90		4	66	1997	11	RHY (DW10TD)	02/99→03/05
2.0 HDi 109		4	80	1997	11	RHZ (DW10ATED)	05/01→03/05
<b>XSARA Break</b>							
2.0 HDi 90		4	66	1997	11	RHY (DW10TD)	02/99→08/05
2.0 HDi 109		4	80	1997	11	RHZ (DW10ATED)	05/01→08/05
<b>XSARA Coupe</b>							
2.0 HDi 90		4	66	1997	11	RHY (DW10TD)	02/99→03/05
2.0 HDi 109		4	80	1997	11	RHZ (DW10ATED)	05/01→03/05
<b>XSARA PICASSO</b>							
2.0 HDi		4	66	1997	11	RHY (DW10TD)	12/99→
<b>BERLINGO</b>							
2.0 HDi 90		4	66	1997	11	RHY (DW10TD)	12/99→
<b>JUMPER</b>							
2.0 HDi		4	62	1997	11	DW10UTD	11/01→04/02
2.0 HDi		4	62	1997	11	DW10UTD	04/02→
2.2 HDi		4	74	2179	11	DW12TED	04/02→
<b>JUMPY</b>							
2.0 HDi 95		4	69	1997	11	RHX	10/99→
2.0 HDi 110		4	80	1997	11	RHZ (DW10ATED)	03/00→

**FIAT**
**ULYSSE**

2.0 JTD		4	80	1997	11	RHZ	10/99→08/02
2.0 JTD		4	79	1997	11	RHM(DW10ATED4)	05/03→
2.0 JTD		4	80	1997	11	RHW(DW10ATED4)	08/02→
2.2 JTD		4	94	2179	11	4HW(DW12ATED4)	08/02→

**DUCATO (230L)**

2.0 JTD		4	62	1997	11	RHV (DW10)	10/01→04/02
---------	--	---	----	------	----	------------	-------------

			<b>kW</b>	<b>cc</b>	<b>V</b>		
---	---	---	-----------	-----------	----------	---	---

**FIAT****DUCATO (244)**

2.0 JTD	4	62	1997	11	RHV (DW10)	04/02→
---------	---	----	------	----	------------	--------

**SCUDO**

2.0 JTD	4	69	1997	11	RHX	12/99→
---------	---	----	------	----	-----	--------

2.0 JTD	4	80	1997	11	RHZ	12/02→
---------	---	----	------	----	-----	--------

**LANCIA****PHEDRA**

2.0 JTD	4	79	1997	11	RHM	07/03→
---------	---	----	------	----	-----	--------

2.0 JTD	4	80	1997	11	RHW(DW10ATED4)	09/02→
---------	---	----	------	----	----------------	--------

2.2 JTD	4	94	2179	11	4HW(DW12ATED4)	09/02→
---------	---	----	------	----	----------------	--------

**ZETA**

2.0 JTD	4	80	1997	11	RHW	09/99→09/02
---------	---	----	------	----	-----	-------------

**PEUGEOT****206**

2.0 HDI 90	4	66	1997	11	RHY (DW10TD)	12/99→
------------	---	----	------	----	--------------	--------

**306**

2.0 HDI 90	4	66	1997	11	RHY (DW10TD)	06/99→04/02
------------	---	----	------	----	--------------	-------------

**307**

2.0 HDi 90	4	66	1997	11	RHY (DW10TD)	08/00→
------------	---	----	------	----	--------------	--------

2.0 HDi 110	4	79	1997	11	RHS (DW10ATED)	08/00→
-------------	---	----	------	----	----------------	--------

2.0 HDi 135	4	100	1997	11	RHR (DW10BTED4)	10/03→
-------------	---	-----	------	----	-----------------	--------

**406**

2.0 HDI 90	4	66	1997	11	RHY (DW10TD)	02/99→10/04
------------	---	----	------	----	--------------	-------------

2.0 HDi 110	4	79	1997	11	RHS (DW10ATED), RHZ (DW10ATED)	08/01→10/04
-------------	---	----	------	----	--------------------------------	-------------

2.0 HDI 110	4	80	1997	11	RHZ (DW10ATED)	06/98→04/04
-------------	---	----	------	----	----------------	-------------

2.2 HDi	4	98	2179	11	4HX (DW12TED4/FAP)	03/00→12/04
---------	---	----	------	----	--------------------	-------------

**407**

2.0 HDi 135	4	100	1997	11	RHR (DW10BTED4)	05/04→
-------------	---	-----	------	----	-----------------	--------

**607**

2.0 HDI	4	80	1997	11	RHZ (DW10ATED)	05/00→
---------	---	----	------	----	----------------	--------

2.2 HDI	4	98	2179	11	4HX (DW12TED4/FAP)	02/00→
---------	---	----	------	----	--------------------	--------

**806**

2.0 HDI	4	80	1997	11	RHZ (DW10ATED)	08/99→08/02
---------	---	----	------	----	----------------	-------------

2.0 HDI 16V	4	80	1997	11	RHW (DW10ATED4)	08/99→08/02
-------------	---	----	------	----	-----------------	-------------

**807**

2.0 HDi	4	79	1997	11	RHK(DW10UTED4), RHM(DW10A-TED4), RHT (DW10ATED4), RHW (DW10ATED4)	06/02→
---------	---	----	------	----	---	--------

			<b>kW</b>	<b>cc</b>	<b>V</b>		
--	---	---	-----------	-----------	----------	---	---

**PEUGEOT**

2.2 HDi	4	94	2179	11	4HX (DW12TED4/FAP)	06/02→
---------	---	----	------	----	--------------------	--------

**BOXER**

2.0 HDi	4	62	1997	11		08/01→04/02
2.0 HDi	4	62	1997	11	RHV (DW10UTD)	04/02→
2.2 HDi	4	74	2179	11	4HY (DW12UTED)	04/02→

**EXPERT**

2.0 HDi	4	80	1997	11	RHZ (DW10ATED)	07/00→
2.0 HDi	4	80	1997	11	RHW (DW10ATED4)	07/00→

**PARTNER**

2.0 HDi	4	66	1997	11	RHY (DW10TD)	04/00→
2.0 HDi 4x4	4	66	1997	11	RHY (DW10TD)	04/04→

**SUZUKI**
**GRAND VITARA**

2.0 HDi 110	4	80	1997	11	RHW	07/01→
-------------	---	----	------	----	-----	--------

# UC14A

## 062900006304

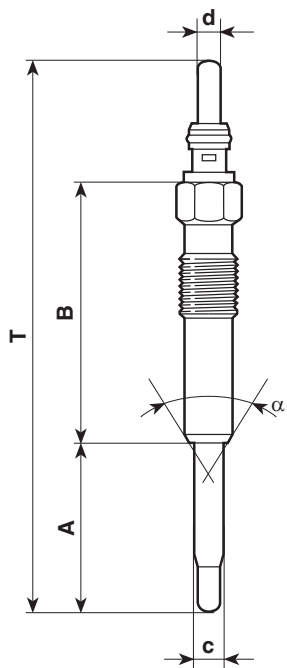

T	97
A	30
B	46
c	5
d	4
$\alpha$	63°
	M10X1
	10
V	11
Amp	15
	4''
Nm	10÷15

<b>BERU</b>	0100226343 GN007 GN046
<b>BOSCH</b>	0250202023
<b>CHAMPION</b>	CH181
<b>NGK</b>	DP20 Y741U



### FORD

#### GALAXY

1.9 TDI	4	66	1896	11	1Z, AHU, ANU	11/01→
1.9 TDI	4	85	1896	11	AUY	10/01→
1.9 TDI	4	96	1896	11	ASZ	02/03→
1.9 TDI	4	110	1896	11	BTB	05/05→

#### SCORPIO II

2.5 TD	4	85	2500	11	SCC	10/94→08/98
2.5 TD	4	92	2500	11	VM	09/96→08/98

### JEEP

#### GRAND CHEROKEE I

2.5 TD	4	85	2499	11	M51, M52	10/95→04/99
--------	---	----	------	----	----------	-------------

#### GRAND CHEROKEE II

2.7 CRD 4x4	5	120	2685	11		10/01→
3.1 TD	5	103	3125	11		04/99→

**OPEL**
**FRONTERA**

2.5 TDS	4	85	2499	11	25TDS (VM41B)	09/96→10/98
---------	---	----	------	----	---------------	-------------

**ROVER**
**800 (XS)**

825 D/SD (XS)	4	87	2500	11	425 SL1RR, 492 4 SHIRG	05/95→
825 SD	4	87	2500	11	425 SL1RR, 492 4 SHIRG	05/95→02/99

**SEAT**
**ALHAMBRA**

1.9 TDI	4	96	1896	11	ASZ	11/02→
---------	---	----	------	----	-----	--------

**AROSA**

1.4 TDI	3	55	1422	11	AMF	11/01→
---------	---	----	------	----	-----	--------

**CORDOBA**

1.4 TDI	3	51	1422	11	BNM	05/05→
1.4 TDI	3	55	1422	11	AMF	10/02→
1.4 TDI	3	59	1422	11	BMS, BNV	06/05→
1.9 SDI	4	47	1896	11	ASY	09/02→
1.9 TDI	4	74	1896	11	ATD, AXR, BMT	09/02→
1.9 TDI	4	96	1896	11	ASZ, BLT	10/02→

**SEAT**
**IBIZA IV**

1.4 TDI	3	51	1422	11	BNM	05/05→
1.4 TDI	3	55	1422	11	AMF	05/02→
1.4 TDI	3	59	1422	11	BMS, BNV	06/05→
1.9 SDI	4	47	1896	11	ASY	02/02→
1.9 TDI	4	74	1896	11	ATD, AXR, BMT	02/02→
1.9 TDI	4	96	1896	11	ASZ, BLT	02/02→

**LEON**

1.9 TDI	4	96	1896	11	ASZ	05/03→
---------	---	----	------	----	-----	--------

**TOLEDO II**

1.9 TDI	4	96	1896	11	ASZ	05/03→05/06
---------	---	----	------	----	-----	-------------

**SKODA**
**FABIA**

1.4 TDI	3	51	1422	11	BNM	10/05→
1.4 TDI	3	55	1422	11	AMF	04/03→
1.4 TDI	3	59	1422	11	BNV	10/05→



			<b>kW</b>	<b>cc</b>	<b>V</b>		
---	---	---	-----------	-----------	----------	---	---

**SKODA**

1.9 TDI RS	4	96	1896	11	ASZ, BLT	06/03→
------------	---	----	------	----	----------	--------

**OCTAVIA**

1.9 TDI 4x4	4	74	1896	11	ATD	12/02→
-------------	---	----	------	----	-----	--------

1.9 TDI	4	96	1896	11	ASZ	01/03→
---------	---	----	------	----	-----	--------

**ROOMSTER**

1.4 TDI	3	51	1422	11	BNM	07/06→
---------	---	----	------	----	-----	--------

1.4 TDI	3	59	1422	11	BMS, BNV	09/06→
---------	---	----	------	----	----------	--------

**SUPERB**

1.9 TDI	4	74	1896	11	AVB	08/02→
---------	---	----	------	----	-----	--------

1.9 TDI	4	96	1896	11	AWX	02/02→
---------	---	----	------	----	-----	--------

**VAUXHALL****FRONTERA**

2.5 TDS	4	85	2499	11	25TDS (VM41B)	09/96→10/98
---------	---	----	------	----	---------------	-------------

**VOLKSWAGEN****BORA**

1.9 TDI	4	74	1896	11	ATD, AXR	09/00→05/05
---------	---	----	------	----	----------	-------------

1.9 TDI 4motion	4	74	1896	11	ATD	09/00→05/05
-----------------	---	----	------	----	-----	-------------

1.9 TDI	4	96	1896	11	ASZ 172.600001→	11/00→05/05
---------	---	----	------	----	-----------------	-------------

1.9 TDI 4motion	4	96	1896	11	ASZ 172.600001→	11/00→05/05
-----------------	---	----	------	----	-----------------	-------------

1.9 TDI	4	110	1896	11	ARL	11/01→05/05
---------	---	-----	------	----	-----	-------------

1.9 TDI 4motion	4	110	1896	11	ARL	11/01→05/05
-----------------	---	-----	------	----	-----	-------------

**FOX**

1.4 TDI	3	51	1422	11	BNM	04/05→
---------	---	----	------	----	-----	--------

**GOLF IV**

1.9 TDI	4	74	1896	11	ATD, AXR	11/01→06/05
---------	---	----	------	----	----------	-------------

1.9 TDI 4motion	4	74	1896	11	ATD	11/01→06/05
-----------------	---	----	------	----	-----	-------------

1.9 TDI	4	96	1896	11	ASZ	11/01→06/05
---------	---	----	------	----	-----	-------------

1.9 TDI 4motion	4	96	1896	11	ASZ	11/01→06/05
-----------------	---	----	------	----	-----	-------------

1.9 TDI	4	110	1896	11	ARL	11/01→06/05
---------	---	-----	------	----	-----	-------------

1.9 TDI 4motion	4	110	1896	11	ARL	11/01→06/05
-----------------	---	-----	------	----	-----	-------------

**LUPO**

1.2 TDI 3L	3	45	1191	11	ANY, AYZ	11/01→07/05
------------	---	----	------	----	----------	-------------

1.4 TDI	3	55	1422	11	AMF	11/01→07/05
---------	---	----	------	----	-----	-------------

**MULTIVAN V**

1.9 TDI	4	77	1896	11	AXB	04/03→
---------	---	----	------	----	-----	--------

2.5 TDI	5	96	2461	11	AXD, BNZ	04/03→
---------	---	----	------	----	----------	--------

2.5 TDI 4motion	5	96	2461	11	AXD, BNZ	07/04→
-----------------	---	----	------	----	----------	--------

**kW**
**cc**
**V**

**VOLKSWAGEN**

2.5 TDI	5	128	2461	11	AXE, BPC	04/03→
2.5 TDI 4motion	5	128	2461	11	AXE, BPC	07/04→

**NEW BEETLE**

1.9 TDI	4	74	1896	11	ATD, BEW	11/01→
---------	---	----	------	----	----------	--------

**PASSAT**

1.9 TDI	4	74	1896	11	AVB	11/01→
1.9 TDI	4	96	1896	11	AVF, AWX	11/01→05/05
1.9 TDI 4motion	4	96	1896	11	AVF	11/01→05/05

**PHAETON**

5.0 V10 TDI 4motion	10	230	4921	11	AJS	11/02→
---------------------	----	-----	------	----	-----	--------

**POLO**

1.4 TDI	3	51	1422	11	BNM, BWB	04/05→
1.4 TDI	3	55	1422	11	AMF, BAY	10/01→06/05
1.4 TDI	3	55	1422	11	BAY	07/03→
1.4 TDI	3	59	1422	11	BMS, BNV	04/05→
1.9 TDI	4	74	1896	11	ATD, AXR, BMT	10/01→

**SHARAN**

1.9 TDI	4	66	1896	11	1Z, AHU, ANU	11/01→
1.9 TDI	4	85	1896	11	AUY, BVK	11/01→
1.9 TDI 4motion	4	85	1896	11	AUY, BVK	11/01→
1.9 TDI	4	96	1896	11	ASZ	11/02→

**TOUAREG**

2.5 R5 TDI	5	128	2461	11	BAC, BPE	01/03→
5.0 V10 TDI	10	230	4921	11	AYH, BLE, BWF	10/02→

**TOURAN**

1.9 TDI	4	74	1896	11	AVQ	02/03→
---------	---	----	------	----	-----	--------

**TRANSPORTER IV**

1.9 TDI	4	63	1896	11	AXC	04/03→
1.9 TDI	4	77	1896	11	AXB	04/03→
2.5 TDI	5	65	2461	11	AYY	10/01→04/03
2.5 TDI	5	96	2461	11	AXD, BNZ	04/03→
2.5 TDI 4motion	5	96	2461	11	AXD, BNZ	07/04→
2.5 TDI	5	111	2461	11	AXG	05/98→04/03
2.5 TDI	5	128	2461	11	AXE, BPC	04/03→
2.5 TDI 4motion	5	128	2461	11	AXE, BPC	07/04→

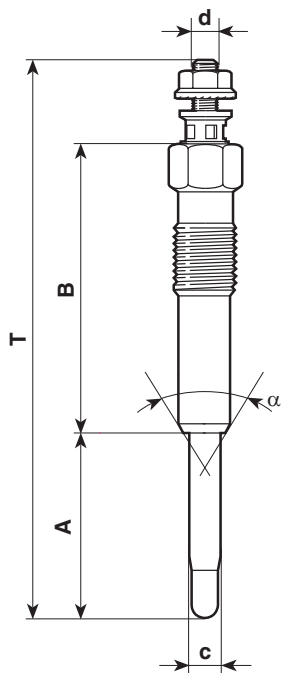
**UC15A**
**062900007304**

T	89
A	30
B	46
c	5
d	M4
$\alpha$	63°
	M10X1
	10
V	11
Amp	15
	4''
Nm	10÷15



<b>BERU</b>	0100226188 912MJ GN016 GN912
<b>BOSCH</b>	0250201010 0250201010 0250201020 0250201020 0250202020
<b>CHAMPION</b>	CH185
<b>NGK</b>	DP10 DP9 Y503J Y503R Y731U Y731U

**CITROËN**
**AX**

1.5 D	4	40	1527	11	VJY (TUD5)	08/94→12/97
1.5 D	4	43	1527	11	VJZ (TUD5)	08/94→12/97

**SAXO**

1.5 D	4	42	1527	11	VJZ (TUD5)	09/96→06/01
1.5 D	4	40	1527	11	VJY (TUD5)	09/96→09/03

**XSARA**

1.5 D	4	42	1527	11	VJZ (TUD5)	04/97→09/00
1.9 D	4	51	1868	11	WJY (DW8B), WJZ (DW8)	07/98→03/05

**XSARA Break**

1.5 D	4	42	1527	11	VJZ (TUD5)	10/97→09/00
1.9 D	4	51	1868	11	WJY (DW8B), WJZ (DW8)	07/98→08/05

**XSARA Coupe**

1.9 D	4	51	1868	11	WJY (DW8B), WJZ (DW8)	02/99→03/05
-------	---	----	------	----	-----------------------	-------------

**BERLINGO**

1.9 D	4	51	1868	11	WJY (DW8B), WJZ (DW8)	07/98→
1.9 D 4WD	4	51	1868	11	WJZ (DW8)	07/98→

**kW**
**cc**
**V**

**CITROËN**
**JUMPY**

1.9 D 70	4	51	1868	11	WJZ (DW8)	04/98→
----------	---	----	------	----	-----------	--------

**FIAT**
**DUCATO (230L)**

1.9 D	4	50	1905	11	DJY	04/98→04/02
-------	---	----	------	----	-----	-------------

**SCUDO**

1.9 D	4	51	1868	11	WJZ (DW8)	04/98→
-------	---	----	------	----	-----------	--------

**NISSAN**
**MICRA**

1.5 D	4	42	1527	11	TUD5 (VJX) Peugeot	02/98→02/03
-------	---	----	------	----	--------------------	-------------

**PEUGEOT**
**106**

1.5 D	4	40	1527	11	VJY (TUD5)	06/94→
-------	---	----	------	----	------------	--------

1.5 D	4	43	1527	11		06/94→04/96
-------	---	----	------	----	--	-------------

1.5 D	4	42	1527	11	VJX (TUD5)	10/00→
-------	---	----	------	----	------------	--------

**206**

1.9 D	4	51	1868	11	WJZ (DW8)	09/98→11/01
-------	---	----	------	----	-----------	-------------

**306**

1.9 D	4	51	1868	11	WJY (DW8B), WJZ (DW8)	09/98→04/02
-------	---	----	------	----	-----------------------	-------------

**PARTNER**

1.9 D	4	51	1868	11	WJY (DW8B), WJZ (DW8)	06/96→
-------	---	----	------	----	-----------------------	--------

1.9 D 4x4	4	51	1868	11	WJY (DW8B)	04/04→
-----------	---	----	------	----	------------	--------

**ROVER**
**100 (METRO)**

115 D	4	42	1527	11	TUD 5	12/94→12/98
-------	---	----	------	----	-------	-------------

**TOYOTA**
**COROLLA**

1.9 D (WZE110_)	4	51	1867	11	1WZ	02/00→01/02
-----------------	---	----	------	----	-----	-------------

# UC16A

062900009304

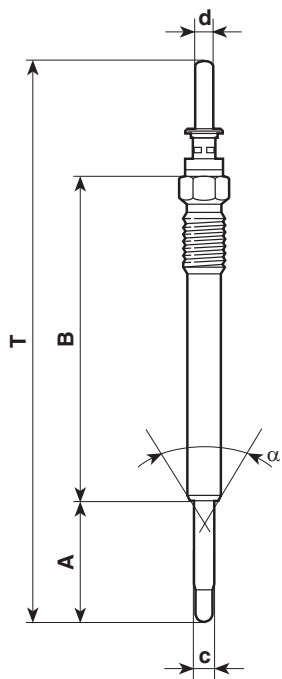

T	133
A	29
B	77
c	5
d	4
$\alpha$	63°
	M10X1
	10
V	11
Amp	15
	4"
Nm	10÷15

<b>BERU</b>	0100226300 GN025 GN992
<b>BOSCH</b>	0250202039 0250202042
<b>CHAMPION</b>	CH207
<b>NGK</b>	DP14 Y748U



## OPEL

### ASTRA G

2.0 DI	4	60	1995	11	X 20 DTL, Y 20 DTL	02/98→01/05
2.0 DTI 16V	4	74	1995	11	X 20 DTH, Y 20 DTH	08/99→01/05

### FRONTERA

2.2 DTI	4	85	2171	11	X 22 DTH	10/98→07/00
---------	---	----	------	----	----------	-------------

### SINTRA

2.2 DTI	4	85	2171	11	X 22 DTH	07/97→04/99
---------	---	----	------	----	----------	-------------

### VECTRA B

2.0 DI 16V	4	60	1995	11	X 20 DTL	11/96→04/02
2.0 DTI 16V	4	74	1995	11	X 20 DTH	03/98→06/00

### ZAFIRA

2.0 DI 16V	4	60	1995	11	X 20 DTL	10/99→06/05
2.0 DTI 16V	4	74	1995	11	Y 20 DTH	09/00→06/05

## SAAB

### 9-3

2.2 TiD	4	85	2171	11	D223L, X 22 DTH	02/98→11/00
---------	---	----	------	----	-----------------	-------------

**kW**
**cc**
**V**

**SAAB**
**9-5**

2.2 TiD	4	88	2171	11	D223L	03/02→
---------	---	----	------	----	-------	--------

**VAUXHALL**
**ASTRA Mk IV**

2.0 DI	4	60	1995	11	X 20 DTL, Y 20 DTL	02/98→03/04
2.0 DTI 16V	4	74	1995	11	X 20 DTH, Y 20 DTH	08/99→

**FRONTERA**

2.2 DTI	4	85	2171	11	X 22 DTH	10/98→
---------	---	----	------	----	----------	--------

**OMEGA**

2.0 DTI 16V	4	74	1995	11	X 20 DTH	10/98→09/00
-------------	---	----	------	----	----------	-------------

**SINTRA**

2.2 DTI	4	85	2171	11	X 22 DTH	07/97→04/99
---------	---	----	------	----	----------	-------------

**VECTRA**

1.7 TD	4	60	1686	11	X 17 DT	08/95→12/96
2.0 DI 16V	4	60	1995	11	X 20 DTL	11/96→
2.0 DTI 16V	4	74	1995	11	X 20 DTH	03/98→
2.2 DTI 16V	4	92	2172	11	Y 22 DTR	09/00→

**ZAFIRA**

2.0 DI 16V	4	60	1995	11	X 20 DTL	10/99→
2.0 DTI 16V	4	74	1995	11	Y 20 DTH	04/99→
2.2 DTI	4	85	2171	11	X 22 DTH	09/99→

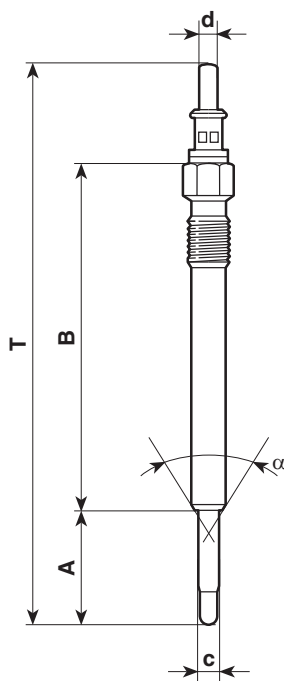
**UC17A**
**062900012304**

T	133
A	27
B	80
c	5
d	4
$\alpha$	63°
	M10X1
	10
V	11,5
Amp	15
	4"
Nm	10÷15

<b>BERU</b>	0100226379 GN003
<b>BOSCH</b>	0250202029 0250202045
<b>CHAMPION</b>	CH218
<b>NGK</b>	DP11 Y745U Y925U

**CHRYSLER**
**PT CRUISER**

Model	Cylinders	kW	cc	V	Code	Year
2.2 CRD	4	89	2148	11.5	EDJ	03/02→
2.2 CRD	4	110	2148	11.5		08/05→

**MERCEDES-BENZ**
**C-CLASS (W202)**

C 200 CDI	4	75	2151	11.5	OM 611.960	03/98→05/00
C 220 CDI	4	92	2151	11.5	OM 611.960	09/97→05/00

**C-CLASS (W203)**

C 200 CDI	4	75	2148	11.5	OM 646.962	02/01→
C 200 CDI	4	85	2148	11.5	OM 611.962	09/00→
C 200 CDI	4	90	2148	11.5	OM 646.962	04/03→
C 220 CDI	4	105	2148	11.5	OM 611.962	05/00→
C 220 CDI	4	110	2148	11.5	OM 646.963	02/04→
C 270 CDI	5	125	2685	11.5	OM 612.962	12/00→

**CLK (C209)**

270 CDI	5	125	2685	11.5	OM 612.962, OM 612.967	10/02→
---------	---	-----	------	------	------------------------	--------

**MERCEDES-BENZ**
**E-CLASS (W210)**

E 200 CDI	4	75	2151	11.5	OM 611.961	06/98→03/02
E 200 CDI	4	85	2148	11.5	OM 611.961	07/99→03/02
E 220 CDI	4	92	2151	11.5	OM 611.961	06/98→07/99
E 220 CDI	4	105	2148	11.5	OM 611.961	07/99→03/02
E 270 CDI	5	125	2685	11.5	OM 612.961	07/99→03/03
E 320 CDI	6	145	3226	11.5	OM 613.961	07/99→03/03

**E-CLASS (W211)**

E 200 CDI	4	75	2148	11.5	OM 646.951	07/02→
E 200 CDI	4	90	2148	11.5	OM 646.951	07/02→
E 220 CDI	4	110	2148	11.5	OM 646.961	03/02→
E 270 CDI	5	130	2685	11.5	OM 647.961	03/02→
E 280 CDI	6	130	3222	11.5	OM 648.961	05/04→
E 320 CDI	6	150	3222	11.5	OM 648.961	11/02→
E 400 CDI	8	191	3996	11.5	OM 628.961	02/03→

**G-CLASS (W463)**

G 270 CDI	5	115	2685	11.5	OM 612.966	10/01→
G 400 CDI	8	184	3996	11.5	OM 628.962	12/00→

**M-CLASS (W163)**

ML 270 CDI	5	120	2685	11.5	OM 612.963	12/99→06/05
ML 400 CDI	8	184	3996	11.5	OM 628.963	09/01→06/05

**S-CLASS (W220)**

S 320 CDI	6	145	3222	11.5	OM 613.960	08/99→09/02
S 320 CDI	6	150	3222	11.5	OM 648.960	09/02→08/05
S 400 CDI	8	184	3996	11.5	OM 628.960	06/00→08/05
S 400 CDI	8	191	3996	11.5	OM 628.960	06/03→08/05

**V-CLASS**

V 200 CDI	4	75	2151	11.5	OM 611.980	03/99→07/03
V 220 CDI	4	90	2151	11.5	OM 611.980	03/99→07/03

**VIANO**

CDI 2.2	4	80	2148	11.5	OM 646.982	09/03→
CDI 2.2	4	110	2148	11.5	OM 646.982	09/03→

**SPRINTER 2-t (901, 902)**

208 CDI	4	60	2148	11.5	OM 611.987	04/00→05/06
211 CDI	4	80	2148	11.5	OM 611.981	04/00→05/06
213 CDI	4	95	2148	11.5	OM 611.981	04/00→05/06
216 CDI	5	115	2685	11.5	OM 612.981	04/00→05/06

**SPRINTER 3-t (903)**

308 CDI	4	60	2148	11.5	OM 611.987	04/00→05/06
---------	---	----	------	------	------------	-------------



			<b>kW</b>	<b>cc</b>	<b>V</b>		
--	--	--	-----------	-----------	----------	--	--

**MERCEDES-BENZ**

311 CDI	4	80	2148	11.5	OM 611.981	04/00→05/06
311 CDI 4x4	4	80	2148	11.5	OM 611.981	08/02→05/06
313 CDI	4	95	2148	11.5	OM 611.981	04/00→05/06
313 CDI 4x4	4	95	2148	11.5	OM 611.981	08/02→05/06
316 CDI	5	115	2685	11.5	OM 612.981	04/00→05/06
316 CDI 4x4	5	115	2685	11.5	OM 612.981	08/02→05/06

**SPRINTER 4-t (904)**

408 CDI	4	60	2148	11.5	OM 611.987	04/00→05/06
411 CDI	4	80	2148	11.5	OM 611.981	04/00→05/06
411 CDI 4x4	4	80	2148	11.5	OM 611.981	04/00→05/06
413 CDI	4	95	2148	11.5	OM 611.981	04/00→05/06
413 CDI 4x4	4	95	2148	11.5	OM 611.981	04/00→05/06
416 CDI	5	115	2685	11.5	OM 612.981	04/00→05/06
416 CDI 4x4	5	115	2685	11.5	OM 612.981	04/00→05/06

**VITO (638)**

108 CDI 2.2	4	60	2151	11.5	OM 611A (60 KW CDI)	03/99→07/03
110 CDI 2.2	4	75	2151	11.5	OM 611LA (75 KW CDI)	03/99→07/03
112 CDI 2.2	4	90	2151	11.5	OM 611.980	03/99→07/03

**VITO (W639)**

109 CDI 2.2	4	65	2148	11.5	OM 646.983	09/03→
111 CDI 2.2	4	80	2148	11.5	OM 646.982	09/03→
115 CDI 2.2	4	110	2148	11.5	OM 646.982	09/03→

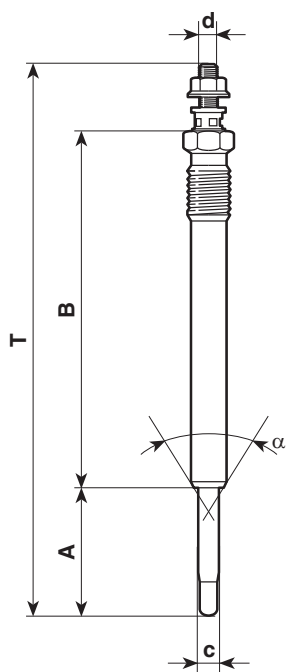
**UC18A**
**062900013304**

T	128
A	30
B	83
c	5
d	M4
$\alpha$	63°
	M10X1
	10
V	11,5
Amp	15
	4"
Nm	10÷15

<b>BERU</b>	0100226365 GN010
<b>BOSCH</b>	0250202041
<b>CHAMPION</b>	CH219
<b>NGK</b>	DP38 Y746J Y746R

**kW**
**cc**
**V**

**MERCEDES-BENZ**
**A-CLASS (W168)**

A 160 CDI	4	44	1689	11.5	OM 668.941	07/98→02/01
A 160 CDI	4	55	1689	11.5	OM 668.940	02/01→08/04
A 170 CDI	4	66	1689	11.5	OM 668.940	07/98→02/01
A 170 CDI	4	70	1689	11.5	OM 668.942	02/01→08/04

**VANEO**

1.7 CDI	4	55	1689	11.5	OM 668.914	02/02→
1.7 CDI	4	67	1689	11.5	OM 668.914	02/02→

# UC19A

## 062900014304

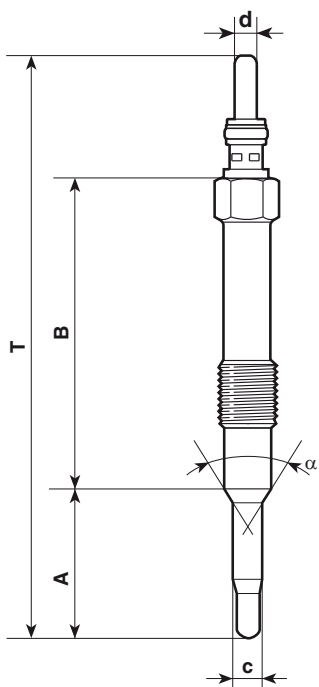

T	102
A	24,5
B	57
c	5
d	4
$\alpha$	63°
	M10X1
	10
V	11
Amp	15
	5''
Nm	10÷15

<b>BERU</b>	GN041
<b>BOSCH</b>	0250202036
<b>CHAMPION</b>	CH222
<b>NGK</b>	DP36 Y534J

			<b>kW</b>	<b>cc</b>	<b>V</b>		
--	--	--	-----------	-----------	----------	--	--

### ALFA ROMEO

#### 145

1.9 JTD	4	77	1910	11	AR 32302	11/99→01/01
---------	---	----	------	----	----------	-------------

#### 146

1.9 JTD	4	77	1910	11	AR 32302	11/99→01/01
---------	---	----	------	----	----------	-------------

#### 147

1.9 JTD	4	74	1910	11	182 B9.000	06/03→
1.9 JTD	4	85	1910	11	937 A2.000	04/01→

#### 156

1.9 JTD	4	81	1910	11	AR 37101	10/00→05/01
1.9 JTD	4	85	1910	11	937 A2.000	05/01→09/05
2.4 JTD	5	100	2387	11	AR 32501	11/99→10/00
2.4 JTD	5	103	2387	11	839 A6.000	10/00→09/05
2.4 JTD	5	110	2387	11	841 C000	03/02→09/05
2.4 JTD	5	129	2387	11	841 G.000	10/03→09/05

#### 156 Sportwagon

1.9 JTD	4	81	1910	11	AR 37101	10/00→05/01
1.9 JTD	4	85	1910	11	937 A2.000	05/01→05/06

			<b>kW</b>	<b>cc</b>	<b>V</b>		
--	---	---	-----------	-----------	----------	---	---

**ALFA ROMEO**

2.4 JTD	5	100	2387	11	AR 32501	05/00→10/00
2.4 JTD	5	103	2387	11	839 A6.000	10/00→05/06
2.4 JTD	5	110	2387	11	841 C000	03/02→05/06
2.4 JTD	5	129	2387	11	841 G.000	10/03→05/06

**159**

1.9 JTDM 8V	4	88	1910	11	939A1.000	09/05→
-------------	---	----	------	----	-----------	--------

**166**

2.4 JTD	5	103	2387	11	839 A6.000	10/00→
2.4 JTD	5	110	2387	11	841 C000	04/02→

**FIAT**
**BRAVA**

1.9 JTD	4	74	1910	11	182 B9.000	09/00→10/01
1.9 JTD 105	4	77	1910	11	182 B4.000	11/99→10/01

**BRAVO**

1.9 JTD	4	74	1910	11	182 B9.000	09/00→10/01
1.9 JTD 105	4	77	1910	11	182 B4.000	11/99→10/01

**GRANDE PUNTO**

1.9 D Multijet	4	88	1910	11	939A1.000	10/05→
1.9 D Multijet	4	96	1910	11	199 A5.000	10/05→

**IDEA**

1.9 JTD	4	74	1910	11	188 B2.000	01/04→
---------	---	----	------	----	------------	--------

**MAREA**

1.9 JTD 105	4	77	1910	11	182 B4.000	11/99→01/01
1.9 JTD 110	4	81	1910	11	186 A6.000	01/01→
2.4 JTD 130	5	96	2387	11	185 A6.000, 839 A5.000	11/99→

**MAREA Weekend**

1.9 JTD 105	4	77	1910	11	182 B4.000	11/99→01/01
1.9 JTD 110	4	81	1910	11	186 A6.000	01/01→
2.4 JTD 130	5	96	2387	11	185 A6.000, 839 A5.000	11/99→

**MULTIPLA**

1.9 JTD 105	4	77	1910	11	182 B4.000	11/99→
1.9 JTD 110	4	81	1910	11	186 A6.000	03/01→07/02
1.9 JTD 115	4	85	1910	11	186 A8.000	07/02→

**PUNTO (188)**

1.9 JTD 80	4	59	1910	11	188 A2.000	09/99→
1.9 JTD	4	63	1910	11	188 A7.000	10/01→
1.9 JTD	4	74	1910	11	188 B2.000	06/03→

			<b>kW</b>	<b>cc</b>	<b>V</b>		
---	---	---	-----------	-----------	----------	---	---

**FIAT****STILO**

1.9 JTD	4	59	1910	11	192 A3.000	02/02→
1.9 D Multijet	4	74	1910	11	192 A9.000	09/05→
1.9 JTD	4	85	1910	11	192 A1.000, 937A7.000	10/01→

**STRADA**

1.9 JTD	4	59	1910	11	188 A2.000	04/03→
---------	---	----	------	----	------------	--------

**DOBLO**

1.9 JTD	4	74	1910	11	182 B9.000, 223 B2.000	10/01→
1.9 JTD	4	77	1910	11	223 A7.000, 223 B1.000	07/03→

**DOBLO Cargo**

1.9 JTD	4	74	1910	11	182 B9.000	10/01→
1.9 JTD	4	77	1910	11	223 A7.000, 223 B1.000	07/03→

**LANCIA****KAPPA**

2.4 JTD	5	100	2387	11	838 A8.000	06/98→10/01
---------	---	-----	------	----	------------	-------------

**KAPPA SW**

2.4 JTD	5	100	2387	11	838 A8.000	06/98→10/01
---------	---	-----	------	----	------------	-------------

**LYBRA**

1.9 JTD	4	77	1910	11	AR 32302	07/99→09/00
1.9 JTD	4	81	1910	11	AR 37101	09/00→05/01
1.9 JTD	4	85	1910	11	937 A2.000	05/01→
2.4 JTD	5	99	2387	11	839 A5.000, AR 32501	07/99→09/00
2.4 JTD	5	103	2387	11	839 A6.000	09/00→05/02
2.4 JTD	5	110	2387	11	841C.000	05/02→

**LYBRA SW**

1.9 JTD	4	77	1910	11	AR 32302	07/99→09/00
1.9 JTD	4	81	1910	11	AR 37101	09/00→05/01
1.9 JTD	4	85	1910	11	937 A2.000	05/01→
2.4 JTD	5	99	2387	11	839 A5.000, AR 32501	10/99→09/00
2.4 JTD	5	103	2387	11	839 A6.000	09/00→
2.4 JTD	5	110	2387	11	841C.000	05/02→

**MUSA**

1.9 D Multijet	4	74	1910	11	188 B2.000	10/04→
----------------	---	----	------	----	------------	--------

**THESIS**

1.9 JTD	4	59	1910	11		10/01→
1.9 JTD	4	81	1910	11		10/01→
2.4 JTD	5	110	2387	11	841C.000	07/02→

**kW**
**cc**
**V**

**OPEL**
**ASTRA H**

1.9 CDTI	4	74	1910	11	Z 19 DT	09/05→
----------	---	----	------	----	---------	--------

**VECTRA C**

1.9 CDTI	4	74	1910	11	Z 19 DT	10/05→
----------	---	----	------	----	---------	--------

**ZAFIRA**

1.9 CDTI	4	74	1910	11	Z 19 DT	07/05→
----------	---	----	------	----	---------	--------

**SUZUKI**
**SX4**

1.9 DDiS	4	88	1910	11	D19AA	06/06→
----------	---	----	------	----	-------	--------

1.9 DDiS 4x4	4	88	1910	11	D19AA	06/06→
--------------	---	----	------	----	-------	--------

**VAUXHALL**
**SIGNUM**

1.9 CDTI	4	88	1910	11	Z 19 DT	04/04→
----------	---	----	------	----	---------	--------

**ZAFIRA**

1.9 CDTI	4	88	1910	11	Z 19 DT	07/05→
----------	---	----	------	----	---------	--------

**VOLVO**
**S40**

1.9 DI	4	75	1870	11	D 4192 T4	07/00→12/03
--------	---	----	------	----	-----------	-------------

1.9 DI	4	85	1870	11	D 4192 T3	07/00→12/03
--------	---	----	------	----	-----------	-------------

**V40**

1.9 DI	4	75	1870	11	D 4192 T4	07/00→06/04
--------	---	----	------	----	-----------	-------------

1.9 DI	4	85	1870	11	D 4192 T3	07/00→06/04
--------	---	----	------	----	-----------	-------------

# UC21A

## 062900017304

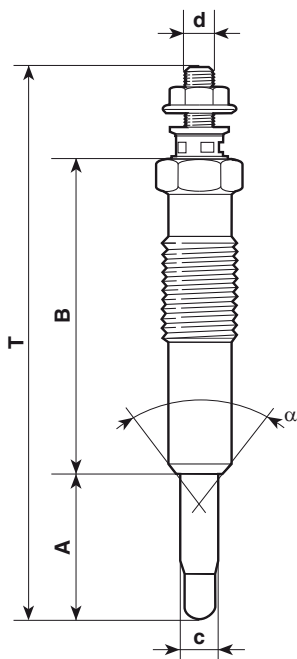

T	93
A	25
B	53
c	5
d	M4
$\alpha$	74°
	M10X1
	10
V	11
Amp	15
	5''
Nm	10÷15

<b>BERU</b>	GN217 GN963
<b>BOSCH</b>	0250202035
<b>CHAMPION</b>	CH217
<b>NGK</b>	DP7 Y506J Y506R

			<b>kW</b>	<b>cc</b>	<b>V</b>		
--	--	--	-----------	-----------	----------	--	--

### OPEL

#### ARENA

1.9 D	4	44	1870	11	F8Q 600, F8Q 606	03/98→08/01
-------	---	----	------	----	------------------	-------------

### RENAULT

#### CLIO

1.9 D	4	47	1870	11	F8Q 630	09/98→
-------	---	----	------	----	---------	--------

#### KANGOO

D 55 1.9	4	40	1870	11	F8Q 662	08/97→
D 65 1.9	4	47	1870	11	F8Q 630	08/97→

#### MEGANE Scenic

1.9 D	4	47	1870	11	F8Q 788	03/97→09/99
-------	---	----	------	----	---------	-------------

#### TRAFIC

1.9 D	4	44	1870	11	F8Q 606	06/97→03/01
-------	---	----	------	----	---------	-------------

# UC22A

## 062900018304

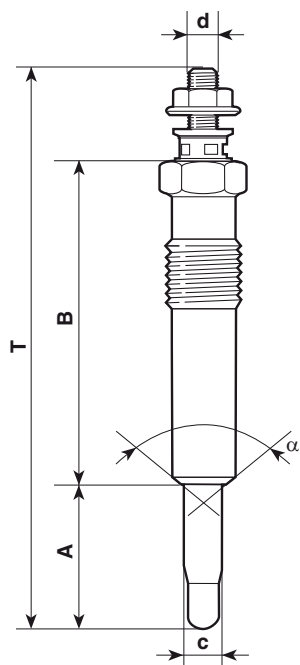

T	95
A	25
B	55
c	5
d	M4
$\alpha$	120°
	M10X1
	10
V	10
Amp	15
	5"
Nm	10÷15

<b>BERU</b>	0100226138 0100226301 0100226384 GN993
<b>BOSCH</b>	0250202131
<b>CHAMPION</b>	CH196
<b>NGK</b>	DP27 Y524J



### FORD

#### FOCUS

1.8 Turbo DI / TDDi	4	66	1753	10	C9DA, C9DB, C9DC	10/98→11/04
1.8 TDCi	4	74	1753	10	FFDA	09/02→11/04
1.8 TDCi	4	85	1753	10	F9DA, F9DB	03/01→11/04

#### FOCUS II

1.8 TDCi	4	85	1753	10	KKDA	01/05→
----------	---	----	------	----	------	--------

#### FOCUS C-MAX

1.8 TDCi	4	85	1753	10	KKDA	01/05→03/07
----------	---	----	------	----	------	-------------

#### GALAXY

1.8 TDCi	4	74	1753	10	FFWA	05/06→
1.8 TDCi	4	92	1753	10	QYWA	05/06→

#### MONDEO IV

1.8 TDCi	4	74	1753	10		03/07→
----------	---	----	------	----	--	--------

#### S-MAX

1.8 TDCi	4	92	1753	10	QYWA	05/06→
----------	---	----	------	----	------	--------

#### TOURNEO CONNECT

1.8 Di	4	55	1753	10	BHPA	06/02→
--------	---	----	------	----	------	--------



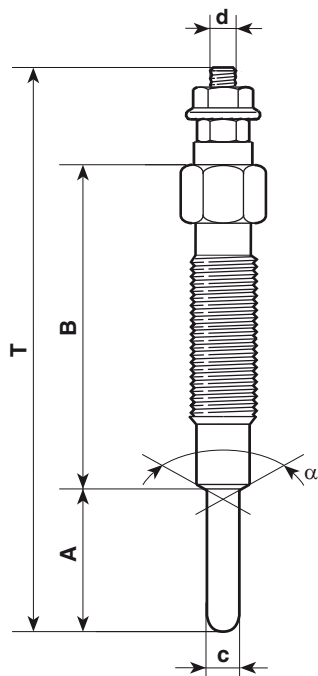

<b>FORD</b>							
			<b>kW</b>	<b>cc</b>	<b>V</b>		
1.8 Turbo Di	4	66	1753	10	HCPA, HCPB	06/02→	
1.8 TDCi	4	81	1753	10	RWPA	08/06→	
<b>TRANSIT</b>							
1.8 Di	4	55	1753	10	BHPA	09/02→	
1.8 TDCi	4	66	1753	10	HCPA, HCPB	09/02→	
1.8 TDCi	4	81	1753	10	RWPA	08/06→	

**UC23A**
**062900019304**

T	87
A	22
B	50
c	5
d	M4
$\alpha$	120°
	M10X1,25
	12
V	11
Amp	11
	10"
Nm	15÷20



<b>BERU</b>	GV291
<b>BOSCH</b>	0250202094
<b>CHAMPION</b>	CH162
<b>NGK</b>	Y-707RS

**kW**
**cc**
**V**

**NISSAN**
**PATHFINDER**

2.7 D 8V	4	59		11		02/93→
2.7 D 8V	4	73		11		01/93→
2.7 TD 4WD	4	96	2664	11	TD27ETi	09/97→

**PATROL**

4.2 D 12V	6	85	4169	11	TD42	11/88→06/97
2.7 TD 8V	4	73		11	TD27	02/93→

**KING CAB**

2.5 D 8V	4	61		11	TD25	01/93→
2.5 TD 8V	4	61		11	TD25	02/98→
2.5 TDi	4			11		05/98→

**PICK UP**

2.5 D 8V	4	59	2494	11	TD25	09/94→02/98
2.5 D 8V	4	61	2494	11	TD25	03/96→

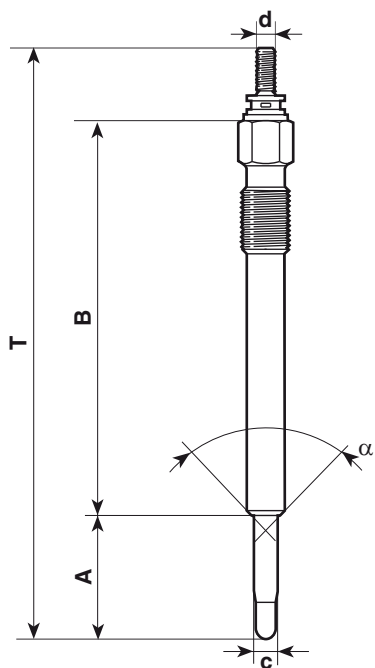
**UC24A**
**062900020304**

T	124
A	26,5
B	83
c	5
d	M4
$\alpha$	90°
	M10X1
	10
V	11,5
Amp	15
	4"
Nm	10÷15

<b>BERU</b>	0100226129 0100226255 783MJ GV783
<b>BOSCH</b>	0250202040
<b>CHAMPION</b>	CH178
<b>NGK</b>	DP34 Y729U

			<b>kW</b>	<b>cc</b>	<b>V</b>		
<b>LAND ROVER</b>							
<b>DEFENDER</b>							
2.5 90 TDI		4	83	2495	11.5	11 L, 16 L, 23 L	09/90→
2.5 Td5 4WD		5	90	2495	11.5		06/98→
<b>DISCOVERY I</b>							
2.5 TDI		4	83	2496	11.5	12 L, 21 L	09/89→06/94
<b>DISCOVERY II</b>							
2.5 TDI		4	83	2495	11.5	12 L, 17 L, 19 L, 21 L	08/96→
2.5 TDI		4	90	2496	11.5	19 L, 22 L	10/95→

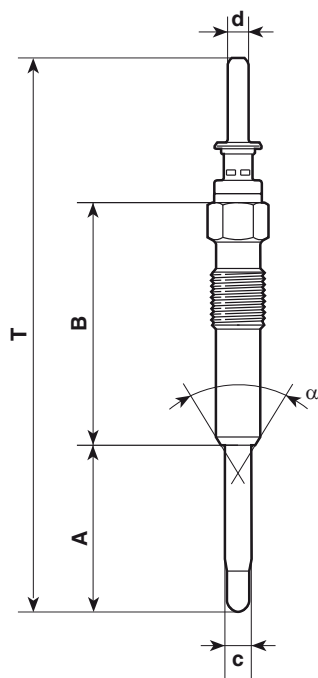
**UC26A**
**062900023304**

T	105
A	32
B	46
c	5
d	4
$\alpha$	63°
	M10X1
	10
V	11
Amp	15
	4"
Nm	10÷15

<b>BERU</b>	0100226362 GN024 GV362
<b>BOSCH</b>	0250202103
<b>CHAMPION</b>	CH203
<b>NGK</b>	DP32 Y507J Y507R

**kW**
**cc**
**V**

**BMW**
**3 (E46)**

320d	4	100	1951	11	M 47 D 20, M47204D1	04/98→09/01
330d	6	135	2926	11	M 57 D 30	10/99→02/05
330xd	6	135	2926	11	M 57 D 30	06/00→02/05

**3 Touring (E46)**

320d	4	100	1951	11	M 47 D 20, M47204D1	03/00→09/01
330d	6	135	2926	11	M 57 D 30	10/99→02/05
330xd	6	135	2926	11	M 57 D 30	06/00→02/05

**5 (E39)**

520 d	4	100	1951	11	M 47 D 20, M47204D1	02/00→06/03
525 d	6	120	2497	11	M 57 D 25, M57256D1	02/00→06/03
530 d	6	142	2926	11	M 57 D 30	08/98→09/00
530 d	6	142	2926	11	M 57 D 30	09/00→06/03

**5 Touring (E39)**

520 d	4	100	1951	11	M 47 D 20, M47204D1	02/00→06/03
525 d	6	120	2497	11	M 57 D 25, M57256D1	02/00→06/03
530 d	6	135	2926	11	M 57 D 30	08/98→09/00



BMW							
530 d	6	142	2926	11	M 57 D 30		09/00→05/04
7 (E38)							
730 d	6	135	2926	11	M 57 D 30		08/98→04/00
730 d	6	142	2926	11	M57306D1		04/00→11/01
X5 (E53)							
3.0 d	6	135	2925	11	M57306D1		05/01→

LAND ROVER							
FREELANDER							
2.0 Td4	4	80	1951	11			11/01→
2.0 Td4	4	82	1951	11			11/00→
RANGE ROVER III							
3.0 TD 6	6	130	2926	11			03/02→

MG							
ZT							
2.0 CDTi	4	85	1951	11	204D2		06/02→09/03
2.0 CDTi	4	96	1951	11	204D2		11/02→

OPEL							
OMEGA							
2.5 DTI	6	110	2497	11	Y 25 DT		09/01→07/03

ROVER							
75							
2.0 CDT	4	85	1950	11	M 47 R		02/99→
2.0 CDTi	4	96	1951	11	204D2		02/03→

# UC27A

## 062900024304

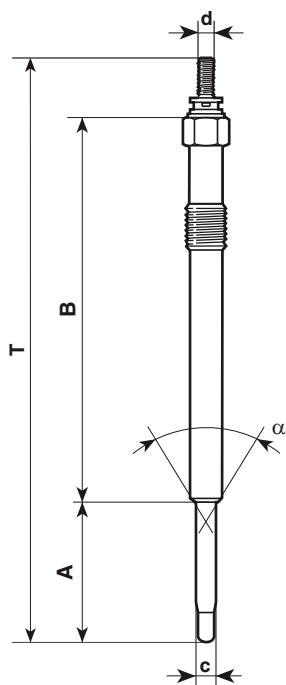

T	146
A	35,5
B	96
c	5
d	M4
$\alpha$	93°
	M10X1
	10
V	11,5
Amp	15
	4"
Nm	10÷12

<b>BERU</b>	0100226385 GN939
<b>BOSCH</b>	0250202130
<b>CHAMPION</b>	CH229
<b>NGK</b>	DP35 Y525J



### FORD

#### MONDEO III

2.0 16V DI / TDDi / TDCi	4	66	1998	11.5	D5BA, SDBA	11/00→
2.0 16V TDDi / TDCi	4	85	1998	11.5	D6BA, HJBA, HJBB, HJBC	11/00→
2.0 TDCi	4	96	1998	11.5	FMBA, N7BA	10/01→
2.2 TDCi	4	114	2198	11.5	QJBA, QJBB	09/04→

#### TRANSIT

2.0 DI	4	55	1998	11.5	D3FA	08/00→
2.0 DI	4	63	1998	11.5	F3FA	08/00→
2.0 DI	4	74	1998	11.5	ABFA	08/00→
2.0 TDCi	4	92	1998	11.5	FIFA	08/02→
2.4 DI [RWD]	4	55	2402	11.5	F4FA	01/00→
2.4 DI	4	66	2402	11.5	D2FA, D2FB, D2FE	01/00→
2.4 TDE	4	85	2402	11.5	FXFA	03/04→
2.4 DI [RWD]	4	88	2402	11.5	D4FA	01/00→
2.4 TDE	4	92	2402	11.5	DOFA	07/01→
2.4 TDCi	4	101	2402	11.5	H9FA	03/04→



**ISUZU**

**TROOPER**

2.2 D 4x4	4	39	2238	11.5	C223	05/84→07/89
-----------	---	----	------	------	------	-------------

**JAGUAR**

**X-TYPE (CF1)**

2.0 D	4	96	1998	11.5	R4-X404	07/03→10/05
-------	---	----	------	------	---------	-------------

# UC28A

062900025304

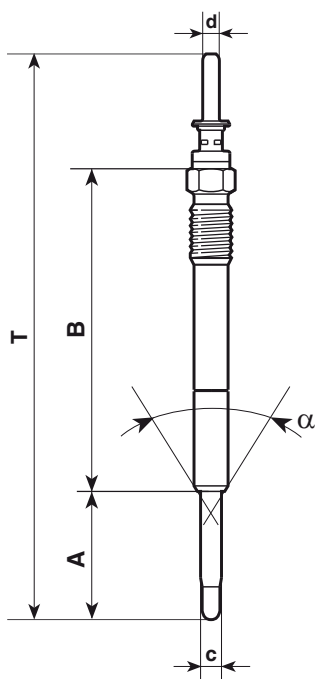

T	135
A	31
B	77
c	5
d	4
$\alpha$	93°
	M10X1
	10
V	11
Amp	15
	4"
Nm	10÷15



<b>BERU</b>	0100226417 GN033
<b>BOSCH</b>	0250202043
<b>CHAMPION</b>	CH231
<b>NGK</b>	DP37 Y523J



## OPEL

### ASTRA G

2.2 DTI	4	92	2172	11	Y 22 DTR	09/02→10/05
---------	---	----	------	----	----------	-------------

### FRONTERA

2.2 DTI	4	85	2171	11	Y 22 DTH	08/00→09/02
2.2 DTI	4	88	2171	11	Y 22 DTH	09/02→

### OMEGA

2.0 DTI 16V	4	74	1995	11	X 20 DTH	09/97→09/00
2.2 DTI 16V	4	88	2171	11	Y 22 DTH	09/00→07/03

### SIGNUM

2.0 DTI	4	74	1994	11	Y 20 DTH	05/03→
2.2 DTI	4	92	2171	11	Y 22 DTR	05/03→

### VECTRA B

2.0 DTI 16V	4	74	1995	11	Y 20 DTH	07/00→04/02
2.2 DTI 16V	4	92	2172	11	Y 22 DTR	09/00→07/03

### VECTRA C

2.0 DTI 16V	4	74	1995	11	Y 20 DTH	04/02→
2.2 DTI 16V	4	92	2172	11	Y 22 DTR	04/02→





**OPEL**

**ZAFIRA**

2.2 DTI 16V	4	92	2172	11	Y 22 DTR	01/02→06/05
-------------	---	----	------	----	----------	-------------

**SAAB**

**9-3**

2.2 TiD	4	92	2171	11	D223L	11/00→09/02
2.2 TiD	4	92	2171	11	D223L	09/02→

**VAUXHALL**

**FRONTERA**

2.2 DTI	4	92	2171	11	Y 22 DTH	08/00→
---------	---	----	------	----	----------	--------

**OMEGA**

2.2 DTI 16V	4	88	2171	11	Y 22 DTH	09/00→
-------------	---	----	------	----	----------	--------

**SIGNUM**

2.0 DTI	4	74	1994	11	Y 20 DTH	05/03→
2.2 DTI	4	92	2188	11	Y 22 DTR	05/03→

**VECTRA**

2.0 DTI 16V	4	74	1995	11	Y 20 DTH	08/99→
2.0 DTI 16V	4	74	1995	11	Y 20 DTH	04/02→
2.2 DTI 16V	4	92	2172	11	Y 22 DTR	09/00→
2.2 DTI 16V	4	92	2172	11	Y 22 DTR	10/03→

**ZAFIRA**

2.2 DTI 16V	4	92	2172	11	Y 22 DTR	01/02→
-------------	---	----	------	----	----------	--------

# UC29A

062900026304

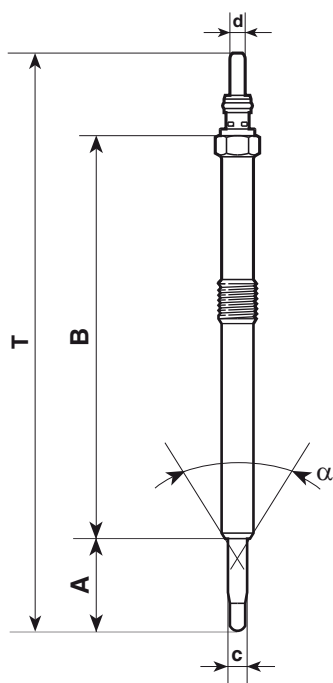

T	150,5
A	24,4
B	105
c	5
d	4
$\alpha$	63°
	M10X1
	10
V	11
Amp	15
	4"
Nm	10÷12

<b>BERU</b>	0100226351 GN026
<b>BOSCH</b>	0250202128
<b>CHAMPION</b>	CH232
<b>NGK</b>	Y517J

			<b>kW</b>	<b>cc</b>	<b>V</b>		
--	--	--	-----------	-----------	----------	--	--

<b>NISSAN</b>							
<b>INTERSTAR</b>							
dCi 90	4	66	2188	11	G9T 722		07/02→
<b>PRIMASTAR</b>							
dCi 140	4	99	2463	11	G9U 730		07/03→

<b>OPEL</b>							
<b>MOVANO</b>							
2.2 DTI	4	66	2188	11	G9T 720		09/00→
2.5 DTI	4	84	2463	11	G9U 720, G9U 754		10/01→
<b>VIVARO</b>							
2.5 DTI	4	99	2463	11	G9U 730		05/03→

<b>RENAULT</b>							
<b>AVANTIME</b>							
2.2 dCi	4	110	2188	11	G9T 712		05/02→05/03
<b>ESPACE</b>							
2.2 dCi	4	95	2188	11	G9T 710		10/00→10/02

			<b>kW</b>	<b>cc</b>	<b>V</b>		
---	---	---	-----------	-----------	----------	---	---

**RENAULT**

2.2 dCi	4	110	2188	11	G9T 742, G9T 743	11/02→
---------	---	-----	------	----	------------------	--------

**LAGUNA**

2.2 dCi	4	110	2188	11	G9T 700, G9T 702	10/01→
---------	---	-----	------	----	------------------	--------

**VEL SATIS**

2.2 dCi	4	85	2188	11	G9T 600	04/04→
---------	---	----	------	----	---------	--------

2.2 dCi	4	102	2188	11	G9T 600, G9T 700	09/04→
---------	---	-----	------	----	------------------	--------

2.2 dCi	4	110	2188	11	G9T 702	06/02→
---------	---	-----	------	----	---------	--------

**MASTER**

2.2 dCi 90	4	66	2188	11	G9T 722	09/00→
------------	---	----	------	----	---------	--------

2.5 dCi 120	4	84	2463	11	G9U 720, G9U 754	10/01→
-------------	---	----	------	----	------------------	--------

2.5 dCi 100	4	73	2463	11	G9U 754	10/03→
-------------	---	----	------	----	---------	--------

**TRAFIC**

2.5 dCi 135	4	99	2464	11	G9U 730	05/03→
-------------	---	----	------	----	---------	--------

**VAUXHALL****MOVANO**

2.2 DTI	4	66	2188	11	G9T 720	09/00→
---------	---	----	------	----	---------	--------

2.5 DTI	4	84	2463	11	G9U 720, G9U 724, G9U 754	10/01→
---------	---	----	------	----	---------------------------	--------

**VIVARO**

2.5 DTI	4	99	2463	11	G9U 730	04/04→
---------	---	----	------	----	---------	--------

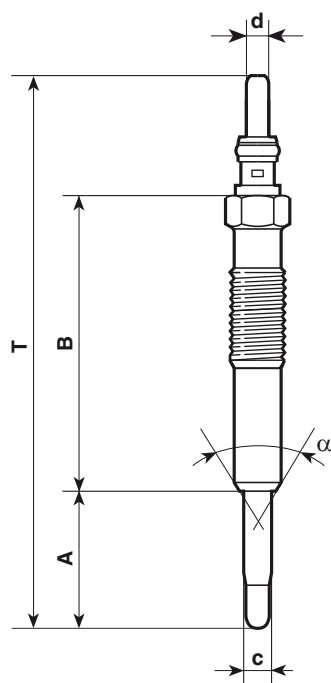
**UC30A**
**062900027304**

T	99
A	25
B	53
c	5
d	4
$\alpha$	63°
	M10X1
	10
V	11
Amp	15
	4"
Nm	10÷15

<b>BERU</b>	0100226375 GN019
<b>BOSCH</b>	0250202129
<b>CHAMPION</b>	CH233
<b>NGK</b>	DP12 Y516J

**kW**
**cc**
**V**

**RENAULT**
**KANGOO**

D 65 1.9	4	47	1870	11	F8Q 632	08/97→
----------	---	----	------	----	---------	--------

**MEGANE Scenic**

1.9 D	4	47	1870	11	F8Q 622, 790	03/97→09/99
-------	---	----	------	----	--------------	-------------

# UC31A

062900028304

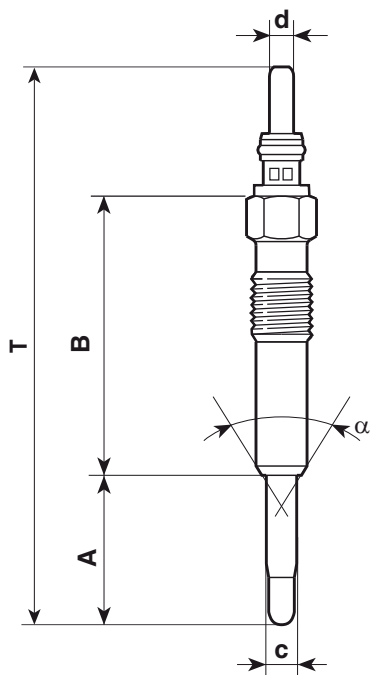

T	92
A	25
B	46
c	5
d	4
$\alpha$	63°
	M10X1
	10
V	11
Amp	15
	4"
Nm	10÷15

<b>BERU</b>	0100226227 0100226373 855MJ 950MJ GN018 GN855
<b>BOSCH</b>	0250202009 0250202022 0250202911
<b>CHAMPION</b>	CH271
<b>NGK</b>	DP18 DP4 Y515J Y732J Y732U

			kW	cc	V		
<b>AUDI</b>							
<b>80</b>							
1.9 TDI		4	66	1896	11	1Z	09/91→12/94
<b>80 Avant</b>							
1.9 TDI		4	66	1896	11	1Z	07/92→01/96
<b>100</b>							
2.5 TDI		5	88	2461	11	1T	01/90→11/90
2.5 TDI		5	85	2461	11	AAT, ABP	12/90→06/94
<b>100 Avant</b>							
2.5 TDI		5	85	2461	11	AAT, ABP	12/90→06/94
<b>A3</b>							
1.9 TDI		4	66	1896	11	AGR, ALH	09/96→07/01
1.9 TDI		4	74	1896	11	ATD, AXR	10/00→
1.9 TDI		4	81	1896	11	AHF, ASV	08/97→07/01
1.9 TDI		4	96	1896	11	ASZ	08/00→05/03
1.9 TDI quattro		4	96	1896	11	ASZ	08/00→05/03
<b>A4</b>							
1.9 TDI		4	55	1896	11	AFF	12/95→11/00

**AUDI**

1.9 TDI	4	66	1896	11	1Z, AHH, AHU	01/95→11/00
1.9 TDI	4	74	1896	11	AVB	05/01→12/04
1.9 TDI	4	81	1896	11	AFN, AVG	10/95→11/00
1.9 TDI quattro	4	81	1896	11	AFN, AVG	09/96→11/00
1.9 TDI	4	85	1896	11	AJM	03/00→11/00
1.9 TDI quattro	4	85	1896	11	AJM, ATJ	03/00→11/00
1.9 TDI	4	96	1896	11	AVF, AWX	11/00→12/04
1.9 TDI quattro	4	96	1896	11	AVF	11/01→12/04

**A4 Avant**

1.9 TDI	4	55	1896	11	AFF	03/96→09/01
1.9 TDI	4	66	1896	11	1Z, AHH, AHU	02/96→09/01
1.9 TDI	4	74	1896	11	AVB	11/01→12/04
1.9 TDI	4	81	1896	11	AFN, AVG	02/96→09/01
1.9 TDI quattro	4	81	1896	11	AFN, AVG	09/96→09/01
1.9 TDI	4	85	1896	11	AJM	03/00→09/01
1.9 TDI quattro	4	85	1896	11	AJM, ATJ	03/00→09/01
1.9 TDI	4	96	1896	11	AVF, AWX	09/01→12/04
1.9 TDI quattro	4	96	1896	11	AVF	11/01→12/04

**A6**

1.9 TDI	4	66	1896	11	1Z, AHU	06/94→10/97
1.9 TDI	4	81	1896	11	AFN, AVG	04/97→10/00
1.9 TDI	4	85	1896	11	AJM	07/00→01/05
1.9 TDI	4	96	1896	11	AVF, AWX	08/01→01/05
2.5 TDI	6	84	2496	11	AAT	01/95→10/97
2.5 TDI	6	85	2496	11	AAT	06/94→10/97
2.5 TDI	6	103	2496	11	AEL	08/94→02/97
2.5 TDI quattro	6	103	2496	11	AEL	10/95→10/97

**A6 Avant**

1.9 TDI	4	66	1896	11	1Z, AHU	06/94→12/97
1.9 TDI	4	81	1896	11	AFN, AVG	02/98→04/01
1.9 TDI	4	85	1896	11	AJM	07/00→01/05
1.9 TDI	4	96	1896	11	AVF, AWX	08/01→01/05
2.5 TDI	6	84	2496	11	AAT	01/95→12/97
2.5 TDI	6	85	2496	11	AAT	06/94→12/97
2.5 TDI	6	103	2496	11	AEL	08/94→12/97
2.5 TDI quattro	6	103	2496	11	AEL	07/95→12/97

**CABRIOLET**

1.9 TDI	4	66	1896	11	1Z, AHU	06/95→08/00
---------	---	----	------	----	---------	-------------

			<b>kW</b>	<b>cc</b>	<b>V</b>		
--	--	--	-----------	-----------	----------	--	--

**DACIA**

**LOGAN**

1.5 dCi	4	48	1461	11	K9K 790	09/05→
1.5 dCi	4	50	1461	11	K9K 792	02/07→
1.5 dCi	4	63	1461	11	K9K 796	09/07→

**LOGAN MCV**

1.5 dCi	4	50	1461	11	K9K 792	02/07→
1.5 dCi	4	63	1461	11	K9K 796	09/07→

**FORD**

**GALAXY**

1.9 TDI	4	66	1896	11	1Z, AHU, ANU	03/95→10/01
1.9 TDI	4	81	1896	11	AFN, AVG	08/97→04/00
1.9 TDI	4	85	1896	11	AUY	04/00→09/01

**MITSUBISHI**

**CARISMA**

1.9 DI-D	4	75	1870	11	F9Q1	09/00→06/06
1.9 DI-D	4	85	1870	11	F9Q2	09/00→06/06

**SPACE STAR**

1.9 DI-D	4	75	1870	11	F9Q1	02/01→
1.9 DI-D	4	85	1870	11	F9Q2	10/02→

**NISSAN**

**ALMERA II**

1.5 dCi	4	60	1461	11	K9K 722	01/03→
---------	---	----	------	----	---------	--------

**MICRA**

1.5 dCi	4	48	1461	11	K9K 704 Renault	01/03→
1.5 dCi	4	50	1461	11		01/03→
1.5 dCi	4	60	1461	11	K9K 722 Renault	09/03→
1.5 dCi	4	63	1461	11		01/03→

**NOTE**

1.5 dCi	4	50	1461	11	K9K 700	03/06→
1.5 dCi	4	63	1461	11		03/06→

**PRIMERA**

1.9 dCi	4	85	1870	11		08/02→
1.9 dCi	4	88	1870	11		04/03→

**QASHQAI**

1.5 dCi	4	78	1461	11		02/07→
---------	---	----	------	----	--	--------

			<b>kW</b>	<b>cc</b>	<b>V</b>		
--	--	--	-----------	-----------	----------	--	--

**NISSAN**
**TIIDA**

1.5 dCi	4	78	1461	11		09/07→
---------	---	----	------	----	--	--------

**INTERSTAR**

dCi 80	4	60	1870	11	F9Q 772	07/02→
--------	---	----	------	----	---------	--------

**KUBISTAR**

1.5 dCi	4	42	1461	11		08/03→
---------	---	----	------	----	--	--------

1.5 dCi	4	45	1461	11		08/05→
---------	---	----	------	----	--	--------

1.5 dCi	4	48	1461	11	K9K 704	08/03→
---------	---	----	------	----	---------	--------

1.5 dCi 70	4	50	1461	11		04/06→
------------	---	----	------	----	--	--------

1.5 dCi	4	60	1461	11	K9K 722	08/03→
---------	---	----	------	----	---------	--------

1.5 dCi 85	4	62	1461	11		04/06→
------------	---	----	------	----	--	--------

**PRIMASTAR**

dCi 80	4	60	1870	11	F9Q 762	03/01→
--------	---	----	------	----	---------	--------

dCi 100	4	74	1870	11	F9Q 760	03/01→
---------	---	----	------	----	---------	--------

**OPEL**
**MOVANO**

1.9 DTI	4	59	1870	11	F9Q 770	09/00→10/01
---------	---	----	------	----	---------	-------------

1.9 DTI	4	60	1870	11	F9Q 774	10/01→
---------	---	----	------	----	---------	--------

**VIVARO**

1.9 DI	4	60	1870	11	F9Q 762	08/01→
--------	---	----	------	----	---------	--------

1.9 DTI	4	74	1870	11	F9Q 760	08/01→
---------	---	----	------	----	---------	--------

**RENAULT**
**CLIO**

1.5 dCi	4	48	1461	11	K9K 700, K9K 704	06/01→
---------	---	----	------	----	------------------	--------

1.5 dCi	4	50	1461	11	K9K 768	06/05→
---------	---	----	------	----	---------	--------

1.5 dCi	4	60	1461	11	K9K 702	06/01→
---------	---	----	------	----	---------	--------

1.5 dCi	4	63	1461	11	K9K 766	02/08→
---------	---	----	------	----	---------	--------

1.5 dCi	4	74	1461	11	K9K 712	01/04→
---------	---	----	------	----	---------	--------

1.5 dCi	4	76	1461	11		02/08→
---------	---	----	------	----	--	--------

1.5 dCi	4	78	1461	11	K9K 764	02/08→
---------	---	----	------	----	---------	--------

1.9 dTi	4	59	1870	11	F9Q 780	02/00→05/05
---------	---	----	------	----	---------	-------------

**ESPACE**

1.9 dTi	4	72	1870	11	F9Q 722	02/99→10/02
---------	---	----	------	----	---------	-------------

1.9 dCi	4	88	1870	11	F9Q 680, F9Q 820, F9Q 826	11/02→
---------	---	----	------	----	---------------------------	--------

**GRAND SCENIC**

1.5 dCi	4	74	1461	11	K9K 728, K9K 729	04/04→
---------	---	----	------	----	------------------	--------

1.9 dCi	4	81	1870	11		05/05→
---------	---	----	------	----	--	--------



			<b>kW</b>	<b>cc</b>	<b>V</b>		
---	---	---	-----------	-----------	----------	---	---

**RENAULT**

1.9 dCi	4	88	1870	11	F9Q 812	04/04→
1.9 dCi	4	96	1870	11	F9Q 816, F9Q 818	05/05→

**KANGOO**

1.5 dCi	4	42	1461	11	K9K 704	12/02→
1.5 dCi	4	48	1461	11	K9K 700, K9K 704	12/01→
1.5 dCi	4	50	1461	11	K9K 714	06/05→
1.5 dCi	4	60	1461	11	K9K 702, K9K 710	07/02→
1.5 dCi	4	62	1461	11	K9K 718	06/05→
1.5 dCi	4	63	1461	11	K9K 800, K9K 802	02/08→
1.5 dCi	4	76	1461	11	K9K 806	02/08→
1.9 dCi 4x4	4	59	1870	11	F9Q 782, F9Q 790	10/01→
1.9 dTi	4	59	1870	11	F9Q 780	02/00→
1.9 dCi 4x4	4	62	1870	11	F9Q 790	07/03→

**LAGUNA**

1.5 dCi	4	81	1461	11	K9K 780	10/07→
1.9 dCi	4	68	1870	11	F9Q 664	03/04→
1.9 dTi	4	72	1870	11	F9Q 710, F9Q 716, F9Q 717	10/97→03/01
1.9 dCi	4	74	1870	11	F9Q 754	10/01→
1.9 dCi	4	77	1870	11	F9Q 752	06/01→
1.9 dCi	4	79	1870	11	F9Q 718	09/99→03/01
1.9 dCi	4	79	1870	11	F9Q 718, F9Q 754	03/01→
1.9 dCi	4	81	1870	11	F9Q 674	01/05→
1.9 dCi	4	88	1870	11	F9Q 750, F9Q 756	03/01→
1.9 dCi	4	96	1870	11	F9Q 758, F9Q 759	05/05→
2.2 dCi	4	102	2188	11	G9T 600	05/05→

**MEGANE**

1.9 dTi	4	59	1870	11	F9Q 744	02/01→
1.9 dTi	4	72	1870	11	F9Q 731, F9Q 736	03/97→02/01
1.9 dCi	4	75	1870	11	F9Q 732, F9Q 733	02/01→08/03

**MEGANE II**

1.5 dCi	4	60	1461	11	K9K 722	11/02→
1.5 dCi	4	63	1461	11	K9K 724	05/05→
1.5 dCi	4	74	1461	11	K9K 729	10/03→
1.5 dCi	4	76	1461	11	K9K 734 FAP	01/07→
1.5 dCi	4	78	1461	11	K9K 734 FAP	05/05→
1.9 dCi	4	68	1870	11	F9Q 808	03/04→
1.9 dCi	4	81	1870	11	F9Q 804, F9Q 816, F9Q 818	05/05→
1.9 dCi	4	88	1870	11	F9Q 800	11/02→
1.9 dCi	4	96	1870	11	F9Q 803, F9Q 816	05/05→

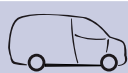
**kW**
**cc**
**V**

**RENAULT**
**MODUS**

1.5 dCi	4	50	1461	11	K9K 768	12/04→
1.5 dCi	4	63	1461	11	K9K 766	12/04→
1.5 dCi	4	76	1461	11		05/07→
1.5 dCi	4	78	1461	11	K9K 764	05/05→

**SCENIC**

1.9 dTi	4	59	1870	11	F9Q 744	02/01→08/03
1.9 dTi	4	72	1870	11	F9Q 731, F9Q 736	09/99→08/03
1.9 dCi	4	75	1870	11	F9Q 732, F9Q 733	11/00→08/03
1.9 dCi RX4	4	75	1870	11	F9Q 740	11/00→08/03

**SCENIC II**

1.5 dCi	4	60	1461	11	K9K 722	06/03→
1.5 dCi	4	63	1461	11	K9K 722, K9K 724	05/05→
1.5 dCi	4	74	1461	11	K9K 728, K9K 729	11/03→
1.5 dCi	4	76	1461	11	K9K 728	01/07→
1.5 dCi	4	78	1461	11	K9K 732	05/05→
1.9 dCi	4	81	1870	11	F9Q 803	05/05→
1.9 dCi	4	88	1870	11	F9Q 812	06/03→
1.9 dCi	4	96	1870	11	F9Q 804	05/05→

**THALIA**

1.5 dCi	4	48	1461	11	K9K 700	04/02→
1.5 dCi	4	50	1461	11		02/03→
1.5 dCi	4	60	1461	11	K9K 702	06/01→

**TWINGO**

1.5 dCi	4	47	1461	11	K9K 740	03/07→
---------	---	----	------	----	---------	--------

**MASTER**

1.9 dTi	4	59	1870	11	F9Q 770	09/00→
1.9 dCi 80	4	60	1870	11	F9Q 772	11/01→

**TRAFIC**

1.9 dCi 80	4	60	1870	11	F9Q 762	03/01→
1.9 dCi 100	4	74	1870	11	F9Q 760	03/01→

**SEAT**
**ALHAMBRA**

1.9 TDI	4	66	1896	11	1Z, AHU, ANU	04/96→09/01
1.9 TDI	4	81	1896	11	AFN	08/96→06/00
1.9 TDI	4	85	1896	11	AUY, BVK	06/00→
1.9 TDI 4motion	4	85	1896	11	AUY	02/01→

			<b>kW</b>	<b>cc</b>	<b>V</b>		
---	---	---	-----------	-----------	----------	---	---

**SEAT****AROSA**

1.4 TDI	3	55	1422	11	AMF	01/00→10/01
1.7 SDI	4	44	1716	11	AKU	08/97→06/04

**CORDOBA**

1.7 SDI	4	44	1716	11		07/97→06/99
1.9 SDI	4	47	1896	11	AEY	08/96→06/99
1.9 SDI	4	50	1896	11	AGP, AQM	06/99→10/02
1.9 TDI	4	66	1896	11	1Z, AHU	08/96→06/99
1.9 TDI	4	66	1896	11	AGR, ALH	06/99→10/02
1.9 TDI	4	81	1896	11	AFN	03/97→06/99
1.9 TDI	4	81	1896	11	ASK, ASV	06/99→10/02

**IBIZA II**

1.7 SDI	4	44	1716	11		07/97→08/99
1.9 SDI	4	47	1896	11	AEY	08/96→08/99
1.9 TDI	4	66	1896	11	1Z, AHU	08/96→08/99
1.9 TDI	4	81	1896	11	AFN	02/97→08/99

**IBIZA III**

1.9 SDI	4	50	1896	11	AGP, AQM	08/99→02/02
1.9 TDI	4	66	1896	11	AGR, ALH	08/99→02/02
1.9 TDI	4	81	1896	11	ASK, ASV	08/99→02/02

**IBIZA IV**

1.9 TDI Cupra R	4	110	1896	11	ARL	01/04→
-----------------	---	-----	------	----	-----	--------

**LEON**

1.9 SDI	4	50	1896	11	AQM	11/99→
1.9 TDI	4	66	1896	11	AGR, ALH	11/99→
1.9 TDI	4	81	1896	11	AHF, ASV	11/99→
1.9 TDI	4	110	1896	11	ARL	02/01→
1.9 TDI Syncro	4	110	1896	11	ARL	05/02→

**TOLEDO I**

1.9 SDI	4	47	1896	11	1Y	12/95→03/99
1.9 TDI	4	66	1896	11	1Z, AHU	08/95→03/99
1.9 TDI	4	81	1896	11	AFN	11/96→03/99

**TOLEDO II**

1.9 SDI	4	50	1896	11	AQM	11/99→06/04
1.9 TDI	4	66	1896	11	AGR, ALH	04/99→05/06
1.9 TDI	4	81	1896	11	AHF, ASV	04/99→05/06
1.9 TDI	4	110	1896	11	ARL	10/00→05/06

**INCA**

1.9 SDI	4	47	1896	11	AEY, AYQ	11/95→
---------	---	----	------	----	----------	--------

**kW**
**cc**
**V**

**SEAT**

1.9 TDI	4	66	1896	11	ALH	09/96→
---------	---	----	------	----	-----	--------

**SKODA**
**FABIA**

1.9 SDI	4	47	1896	11	ASY	11/99→
1.9 TDI	4	74	1896	11	ATD, AXR	01/00→

**OCTAVIA**

1.9 SDI	4	50	1896	11	AGP, AQM	06/97→
1.9 TDI	4	66	1896	11	AGR, ALH	09/96→
1.9 TDI 4x4	4	66	1896	11	AGR	11/99→09/00
1.9 TDI 4x4	4	74	1896	11	ATD	09/00→11/02
1.9 TDI	4	81	1896	11	AHF, ASV	08/97→

**VAUXHALL**
**MOVANO**

1.9 DTI	4	59	1870	11	F9Q 770	09/00→10/01
1.9 DTI	4	60	1870	11	F9Q 774	10/01→

**VIVARO**

1.9 DI	4	59	1900	11		08/01→
1.9 DTI	4	74	1870	11	F9Q 760	08/01→

**VOLKSWAGEN**
**BORA**

1.9 SDI	4	50	1896	11	AGP, AQM	10/98→05/05
1.9 TDI	4	66	1896	11	AGR, ALH, ANU	10/98→06/01
1.9 TDI 4motion	4	66	1896	11	AGR	02/99→06/01
1.9 TDI	4	81	1896	11	AHF, ASV	10/98→06/01
1.9 TDI	4	85	1896	11	AJM, AUJ	12/98→06/01
1.9 TDI 4motion	4	85	1896	11	AJM, AUJ	02/99→06/01
1.9 TDI	4	96	1896	11	ASZ →172.600000	11/00→05/05
1.9 TDI 4motion	4	96	1896	11	ASZ →172.600000	11/00→05/05
1.9 TDI	4	110	1896	11	ARL	05/00→10/01
1.9 TDI 4motion	4	110	1896	11	ARL	05/00→10/01

**GOLF III**

1.9 SDI	4	47	1896	11	AEY	07/95→04/99
1.9 TDI	4	66	1896	11	1Z, AHU, ALE	09/93→05/98
1.9 TDI Syncro	4	66	1896	11	1Z, AHU, ALE	08/95→04/99
1.9 TDI	4	81	1896	11	AFN	04/96→04/99

**VOLKSWAGEN****GOLF IV**

1.9 SDI	4	50	1896	11	AGP, AQM	08/97→06/05
1.9 TDI	4	66	1896	11	AGR, ALH	10/97→05/06
1.9 TDI 4motion	4	66	1896	11	AGR, ALH	07/98→04/02
1.9 TDI	4	74	1896	11	ATD, AXR	09/00→10/01
1.9 TDI 4motion	4	74	1896	11	ATD	09/00→10/01
1.9 TDI	4	81	1896	11	AHF, ASV	08/97→05/04
1.9 TDI	4	85	1896	11	AJM, AUJ	12/98→06/01
1.9 TDI 4motion	4	85	1896	11	AJM, AUJ	09/99→06/01
1.9 TDI	4	96	1896	11	ASZ	11/00→10/01
1.9 TDI 4motion	4	96	1896	11	ASZ	11/00→10/01
1.9 TDI	4	110	1896	11	ARL	05/00→10/01
1.9 TDI 4motion	4	110	1896	11	ARL	02/00→10/01

**LUPU**

1.2 TDI 3L	3	45	1191	11	ANY, AYZ	07/99→10/01
1.4 TDI	3	55	1422	11	AMF	01/99→10/01
1.7 SDI	4	44	1716	11	AKU	09/98→07/05

**NEW BEETLE**





1.9 TDI	4	66	1896	11	ALH	01/98→06/04
1.9 TDI	4	74	1896	11	ATD, BEW	02/01→10/01

**PASSAT**

1.9 TDI	4	66	1896	11	1Z, AHH, AHU	10/93→11/00
1.9 TDI	4	74	1896	11	AVB	02/00→10/01
1.9 TDI	4	81	1896	11	AFN	03/96→08/96
1.9 TDI	4	81	1896	11	AFN, AVG	10/96→11/00
1.9 TDI Syncro/4motion	4	81	1896	11	AFN, AVG	10/96→11/00
1.9 TDI	4	85	1896	11	AJM, ATJ	08/98→11/00
1.9 TDI 4motion	4	85	1896	11	AJM, ATJ	08/99→11/00
1.9 TDI	4	96	1896	11	AVF, AWX	11/00→10/01
1.9 TDI 4motion	4	96	1896	11	AVF	11/00→10/01

**POLO**

1.4 TDI	3	55	1422	11	AMF	10/99→09/01
1.7 SDI	4	42	1716	11	AHG	04/97→10/99
1.7 SDI	4	42	1716	11	AKW	08/97→09/01
60 1.7 SDI	4	44	1716	11	AKU	08/97→10/99
1.7 SDI	4	44	1716	11	AKU	10/99→09/01
64 1.9 SDI	4	47	1896	11	AGD	07/96→10/99
1.9 SDI	4	47	1896	11	AEY	06/97→09/01
1.9 SDI	4	47	1896	11	AGD, ASX	10/99→09/01

  	<b>kW</b>	<b>cc</b>	<b>V</b>			
<b>VOLKSWAGEN</b>						
1.9 SDI	4	47	1896	11	ASY	10/01→
1.9 SDI	4	47	1896	11	ASY	09/02→
1.9 SDI	4	50	1896	11	AGP, AQM	08/99→09/01
1.9 TDI	4	66	1896	11	AGR, AHU, ALE, ALH	05/97→09/01
1.9 TDI	4	81	1896	11	AFN, ASV	06/98→09/01
<b>SHARAN</b>						
1.9 TDI	4	66	1896	11	1Z, AHU, ANU	09/95→10/01
1.9 TDI	4	81	1896	11	AFN, AVG	09/96→04/00
1.9 TDI	4	85	1896	11	AUY, BVK	04/00→10/01
1.9 TDI 4motion	4	85	1896	11	AUY, BVK	04/00→10/01
<b>VENTO</b>						
1.9 SDI	4	47	1896	11	AEY	04/97→09/98
1.9 TDI	4	66	1896	11	1Z, AHU, ALE	09/93→09/98
1.9 TDI	4	66	1896	11	AFN	04/96→09/98
<b>CADDY</b>						
1.7 SDI	4	42	1716	11	AHB	07/96→09/00
1.9 SDI	4	47	1896	11	AEY,	11/95→01/04
1.9 TDI	4	66	1896	11	AEY,	09/96→01/04
1.9 TDI	4	66	1896	11	AHU, ALE, ALH	10/96→01/04
<b>LT II</b>						
2.5 SDI	5	55	2461	11	AGX	07/96→
2.5 TDI	5	61	2461	11	BBE	05/01→
2.5 TDI	5	66	2461	11	APA	05/99→
2.5 TDI	5	70	2461	11	BBF	05/01→
2.5 TDI	5	75	2461	11	AHD	05/96→08/99
2.5 TDI Front Wheel Drive	5	80	2461	11	ANJ, AVR	05/99→
2.8 TDI	4	96	2799	11	ATA	01/99→
<b>TRANSPORTER IV</b>						
2.5 TDI	5	65	2461	11	AJT	12/98→04/03
2.5 TDI	5	75	2461	11	ACV, AUF, AYC	09/95→04/03
2.5 TDI Syncro	5	75	2461	11	ACV, AXL	09/95→04/03
2.5 TDI	5	111	2461	11	AHY, AXG	09/00→04/03
<b>VOLVO</b>						
<b>850</b>						
2.5 TDI	5	103	2461	11	D 5252 T	08/95→12/96
<b>S60</b>						
2.5 TDI	5	103	2461	11	D 5252 T	10/01→



VOLVO							
S70							
Model	Cylinders	Power (kW)	Displacement (cc)	Valves	Engine Code	Production Period	
2.5 TDI	5	103	2461	11	D 5252 T	01/97→11/00	
S80							
2.5 TDI	5	103	2461	11	D 5252 T	01/99→07/06	

# UC32A

062900033304

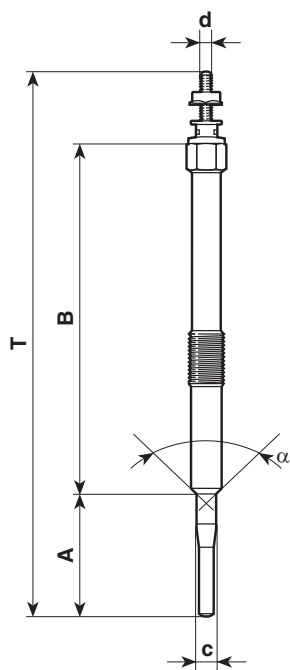

T	160
A	36,4
B	103
c	5
d	M4
$\alpha$	93°
	M10X1
	10
V	11
Amp	10
	6"
Nm	10÷12



<b>BERU</b>	0100226437 0100226480 GN042
<b>BOSCH</b>	CH252



## MINI

### ONE D

Model	Cylinders	kW	cc	V	Notes	Warranty
1.4 D	4	55	1364	11	1ND-TV (Toyota)	06/03→
1.4 D	4	65	1364	11	1ND-TV (Toyota)	06/03→

## TOYOTA

### COROLLA

1.4 D	4	66	1364	11	1ND-TV	07/04→
-------	---	----	------	----	--------	--------

### YARIS

1.4 D-4D	4	55	1364	11	1ND-TV	12/01→
D-4D	4	66	1364	11	1ND-TV	01/06→

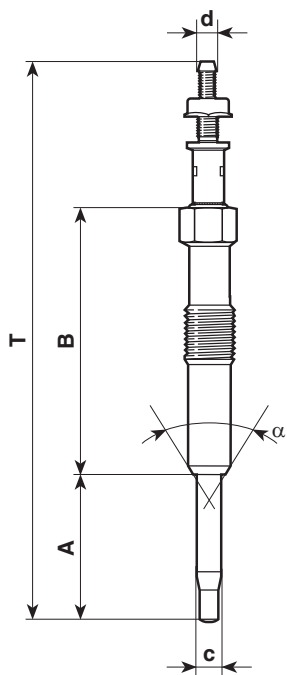

**UC33A**
**062900034304**

T	111,5
A	30
B	53
c	4
d	M4
$\alpha$	63°
	M10X1
	10
V	11
Amp	15
	4"
Nm	10÷12

<b>BERU</b>	0100226422
	0100226522
	GN035
<b>CHAMPION</b>	CH226
<b>NGK</b>	Y749J

			<b>kW</b>	<b>cc</b>	<b>V</b>		
<b>HYUNDAI</b>							
<b>ACCENT</b>							
1.5 CRDi	3	60	1493	11	D3-EA		01/02→
<b>ELANTRA</b>							
2.0 CRDi	4	83	1991	11	D4EA		04/01→
<b>GETZ</b>							
1.5 CRDi	3	60	1493	11	D3-EA		03/03→
<b>MATRIX</b>							
1.5 CRDi	3	60	1496	11	D3-EA		10/01→
<b>SANTA FE</b>							
2.0 CRDi	4	83	1991	11	D4EA		08/01→
2.0 CRDi 4x4	4	83	1991	11	D4EA		04/01→
<b>TRAJET</b>							
2.0 CRDi	4	83	1991	11	D4EA		04/01→
<b>TUCSON</b>							
2.0 CRDi	4	83	1991	11	D4EA		08/04→
2.0 CRDi All-wheel Drive	4	83	1991	11	D4EA		08/04→



**KIA**

**CARENS II**

2.0 CRDi	4	83	1991	11		07/02→
----------	---	----	------	----	--	--------

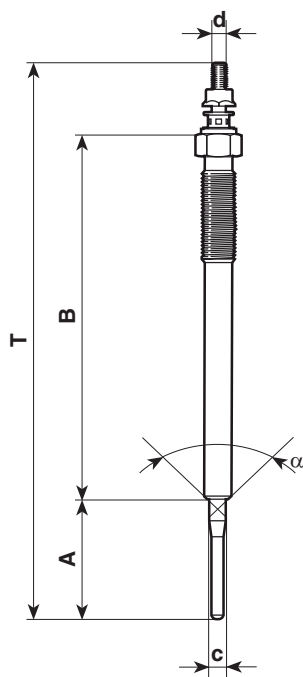
**UC35A**
**062900036304**

T	170
A	37
B	112
c	4
d	M4
$\alpha$	93°
	M10X1,25
	12
V	11
Amp	10,5
	6"
Nm	10÷12

<b>BERU</b>	0250202125
<b>CHAMPION</b>	CH258
<b>NGK</b>	Y531J

**TOYOTA**
**AVENSIS**

2.0 D-4D	4	81	1995	11	1CD-FTV	10/99→01/03
2.0 D-4D	4	85	1995	11	1CD-FTV	08/01→

**COROLLA**

2.0 D-4D	4	66	1995	11	1CD-FTV	07/01→01/02
2.0 D-4D	4	66	1995	11	1CD-FTV	09/01→01/02
2.0 D-4D	4	66	1995	11	1CD-FTV	01/02→05/04
2.0 D-4D	4	66	1995	11	1CD-FTV	01/02→
2.0 D-4D	4	81	1995	11	1CD-FTV	01/02→
2.0 D-4D	4	85	1995	11	1CD-FTV	05/03→

**LAND CRUISER**

3.0 D-4D	4	120	2982	11	1KD-FTV	10/00→
----------	---	-----	------	----	---------	--------

**PREVIA**

2.0 D-4D	4	85	1995	11	1CD-FTV	03/01→
----------	---	----	------	----	---------	--------

**RAV 4**

2.0 D-4D 4WD	4	85	1995	11	1CD-FTV	09/01→
--------------	---	----	------	----	---------	--------



**kW**

**cc**

**V**



**TOYOTA**

**HIACE IV**

2.5 D-4D	4	65	2494	11	2KD-FTV	11/01→
2.5 D-4D	4	75	2494	11	2KD-FTV	11/01→

**HILUX Pickup**

2.5 D-4D	4	65	2494	11	2KD-FTV	11/01→
2.5 D-4D 4WD	4	75	2494	11	2KD-FTV	11/01→

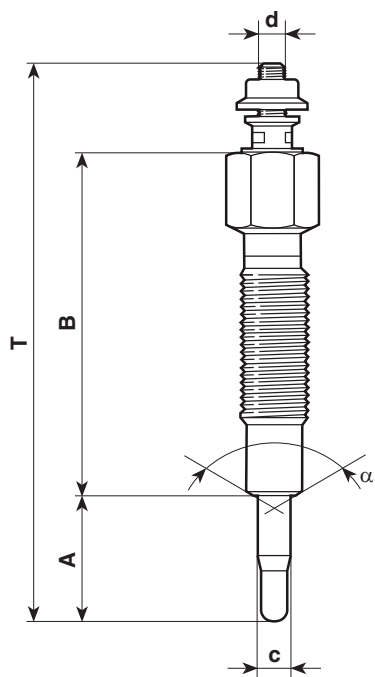
**UC36A**
**062900037304**

T	85
A	19,25
B	52,5
c	5
d	M4
$\alpha$	119°
	M10X1,25
	12
V	11
Amp	15
	4"
Nm	10÷12



<b>BERU</b>	0100226170		
	0100226171		
	853MJ		
	854MJ		
	GN039		
	GN853		
<b>BOSCH</b>	0250202093		
	<b>CHAMPION</b>	CH186	
		<b>NGK</b>	CY08
			CY08
CY51			
CY58			
	CY58		
	Y712RS		

			kW	cc	V		
<b>NISSAN</b>							
<b>SERENA</b>							
2.3 D		4	55	2283	11	CD23	01/95→
<b>TERRANO</b>							
2.7 TD 4WD		4	73	2664	11	TD27T	02/89→02/96
2.7 TD 4WD		4	74	2664	11	TD27T	02/93→01/02
2.7 TDi 4WD		4	92	2664	11	TD27Ti	05/96→
<b>VANETTE CARGO</b>							
2.3 D		4	55	2283	11	LD23	01/95→

# UC37A

## 062900040304

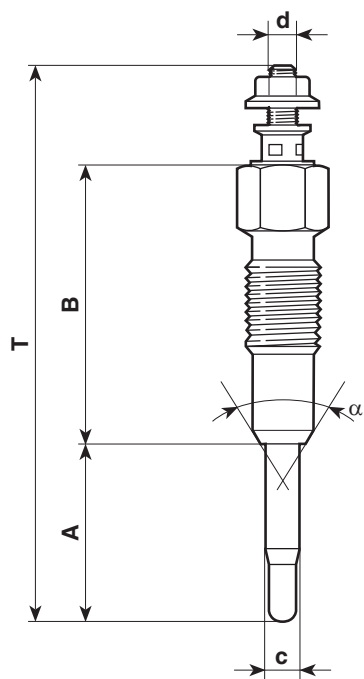

T	76
A	25
B	38
c	5
d	M4
$\alpha$	63°
	M10X1
	10
V	11
Amp	15
	4"
Nm	10÷12

<b>BERU</b>	0100226354 GN012
<b>BOSCH</b>	0250202002
<b>CHAMPION</b>	CH216
<b>NGK</b>	Y502R Y739R



### CITROËN

#### JUMPER

Model	Cylinders	kW	cc	V	Part No.	Validity
2.8 HDi	4	94	2798	11	8140.43S	09/00→04/02
2.8 HDi 4x4	4	94	2798	11	8140.43S	09/00→04/02
2.8 HDi	4	94	2798	11	8140.43S	04/02→
2.8 HDi 4x4	4	94	2798	11	8140.43S	04/02→
2.8 HDi	4	107	2798	11	8140.43N	05/04→

### FIAT

#### DUCATO (230L)

Model	Cylinders	kW	cc	V	Part No.	Validity
2.8 D	4	64	2800	11	8140.63	05/98→04/02
2.8 D 4x4	4	64	2800	11	8140.63	08/98→04/02
2.8 TDI	4	90	2800	11	8140.43	10/97→04/02
2.8 TDI 4x4	4	90	2800	11	8140.43	06/99→04/02
2.8 JTD	4	94	2798	11	8140.43S	11/00→04/02
2.8 JTD 4x4	4	94	2798	11	8140.43S	11/00→04/02

#### DUCATO (244)

2.8 JTD	4	94	2798	11	8140.43S	04/02→
---------	---	----	------	----	----------	--------



**FIAT**

2.8 JTD 4x4	4	94	2798	11	8140.43S	07/02→
-------------	---	----	------	----	----------	--------

**PEUGEOT**

**BOXER**

2.8 HDI	4	94	2798	11	8140.43S	11/00→04/02
2.8 HDi	4	94	2798	11	8140.43S	04/02→
2.8 HDi 4x4	4	94	2798	11	8140.43S	04/02→
2.8 HDi	4	107	2798	11		04/04→

**RENAULT**

**MASTER**

2.5 D	4	59	2499	11	S8U 770	07/98→01/01
2.8 dTI	4	84	2799	11	S9W 702	07/98→10/01

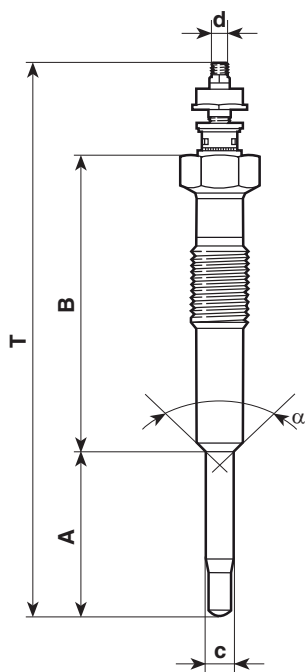
**UC38A**
**062900041304**

T	97
A	28
B	53
c	5
d	M4
$\alpha$	93°
	M10X1,25
	12
V	11
Amp	15
	4"
Nm	10÷12



<b>BERU</b>	0100231114
	GN043
	GV897
	GV967
<b>BOSCH</b>	0250202052
	0250202058
	0250202095
<b>CHAMPION</b>	CH302
<b>NGK</b>	Y147T
	Y532J
	Y703R

**kW**
**cc**
**V**

**TOYOTA**
**AVENSIS**

2.0 TD	4	66	1975	11	2C-TE	09/97→02/03
--------	---	----	------	----	-------	-------------

**CARINA E**

2.0 D	4	54	1975	11	2C	04/92→01/96
2.0 TD	4	61	1975	11	2C-T	01/96→09/97

**COROLLA**

1.8 D	4	47	1840	11	1C	07/87→06/93
1.8 D	4	49	1840	11	1C	08/89→04/92
2.0 D (CE100_)	4	53	1975	11	2C	07/92→04/97
2.0 D (CE110_)	4	53	1975	11	2C-E	04/97→02/00

**LAND CRUISER**

4.2 D (HZJ80_)	6	99	4164	11	1H-Z	01/90→12/97
4.2 TD (HDJ80)	6	118	4164	11	1HD-T	10/92→12/97
4.2 TD (HDJ80)	6	123	4164	11	1HD-T	01/90→12/97

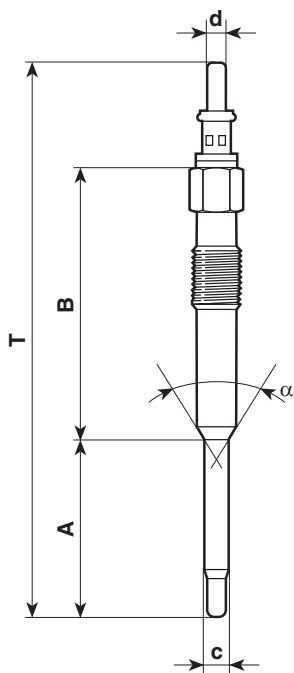

**UC39A**
**062900042304**

T	121
A	40
B	58
c	5
d	4
$\alpha$	63°
	M10X1
	10
V	11,5
Amp	15
	6"
Nm	10÷12

<b>BERU</b>	GN015
<b>CHAMPION</b>	CH228

**SMART**
**CABRIO**

0.8 CDI	3	30	799	11.5	OM 660 DE 8LA	03/01→01/04
---------	---	----	-----	------	---------------	-------------

**CITY-COUPE**

0.8 CDI	3	30	799	11.5	OM 660 DE 8LA	11/99→01/04
---------	---	----	-----	------	---------------	-------------

**FORTWO Cabrio**

0.8 CDI	3	30	799	11.5	OM 660 DE 8LA	01/04→
---------	---	----	-----	------	---------------	--------

0.8 CDI	3	30	799	11.5		01/07→
---------	---	----	-----	------	--	--------

**FORTWO Coupe**

0.8 CDI	3	30	799	11.5	OM 660 DE 8LA	01/04→
---------	---	----	-----	------	---------------	--------

0.8 CDI	3	30	799	11.5		01/07→
---------	---	----	-----	------	--	--------

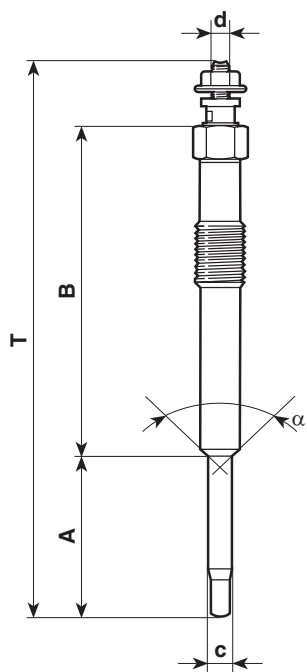
**UC40A**
**062900043304**

T	117
A	34
B	70
c	5
d	M4
$\alpha$	93°
	M10X1
	10
V	11
Amp	15
	4"
Nm	10÷12

<b>BERU</b>	0100226246 964MJ GN964
<b>CHAMPION</b>	CH208
<b>NGK</b>	Y738U

**CITROËN**
**JUMPER**

2.5 TDi	4	79	2446	11	THX (DJ5TED)	12/96→11/00
2.5 TDi 4x4	4	79	2446	11	THX (DJ5TED)	03/00→11/00

**PEUGEOT**
**BOXER**

2.5 TDi	4	79	2446	11	THX (DJ5TED)	01/97→04/02
2.5 TDi 4x4	4	79	2446	11	THX (DJ5TED)	01/97→04/02

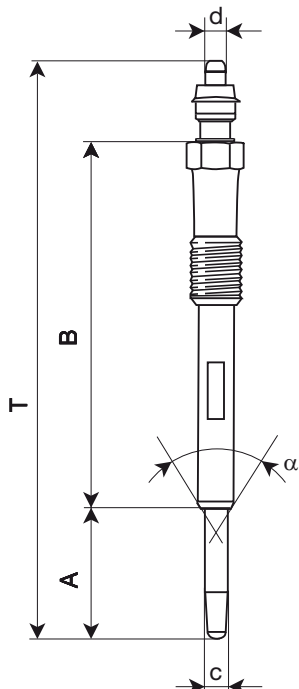
**UC41A**
**062900049304**

T	118
A	26,8
B	75
c	5
d	M4X0,7
$\alpha$	63°
	M10X1
	10
V	11
Amp	15
	4"
Nm	10÷12

<b>BERU</b>	0100226492 GN054
<b>BOSCH</b>	0250202135
<b>CHAMPION</b>	CH268

**CITROËN**
**C5**

2.0 HDi	4	100	1997	11	DW10BTED4	09/04→
---------	---	-----	------	----	-----------	--------

**C5 Break**

2.0 HDi	4	100	1997	11	DW10BTED4	09/04→
---------	---	-----	------	----	-----------	--------

**FORD**
**FOCUS II**

2.0 TDCi	4	100	1997	11	G6DA, G6DB, G6DD	11/04→
----------	---	-----	------	----	------------------	--------

**FOCUS C-MAX**

2.0 TDCi	4	100	1997	11	G6DA, G6DB, G6DD	10/03→03/07
----------	---	-----	------	----	------------------	-------------

**GALAXY**

2.0 TDCi	4	85	1997	11		11/07→
2.0 TDCi	4	96	1997	11	AZWA	05/06→
2.0 TDCi	4	103	1997	11	QXWA, QXWB	05/06→

**S-MAX**

2.0 TDCi	4	85	1997	11		11/07→
2.0 TDCi	4	96	1997	11	AZWA	05/06→



**kW**

**cc**

**V**



**FORD**

2.0 TDCi	4	103	1997	11	QXWB	05/06→
----------	---	-----	------	----	------	--------

**PEUGEOT**

**607**

2.0 HDI	4	100	1997	11	RHR (DW10BTED4)	09/05→
---------	---	-----	------	----	-----------------	--------

**VOLVO**

**S40**

2.0 D 16V	4	100	1998	11	D 4204 T	01/04→
-----------	---	-----	------	----	----------	--------

**V50**

2.0 D	4	100	1998	11	D 4204 T	04/04→
-------	---	-----	------	----	----------	--------

**UC42A**

062900050304

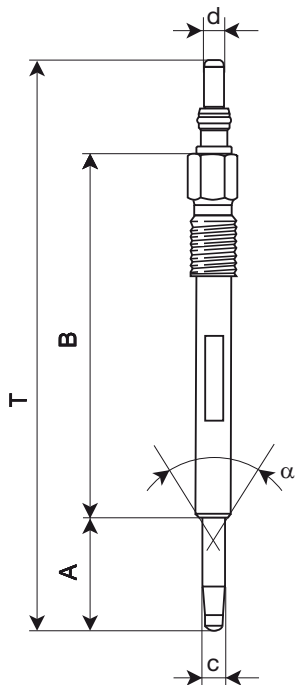

T	130
A	25,5
B	83
c	5
d	4
$\alpha$	93°
	M10X1
	10
V	11,5
Amp	15
	4"
Nm	10÷12

**BERU** 0100226435  
GN050

**CHAMPION** CH275



**kW**

**cc**

**V**



**VOLKSWAGEN**

**LT II**

2.8 TDI

4

116

2799

11

AUH, BCQ

04/02→

# UC43A

062900053304

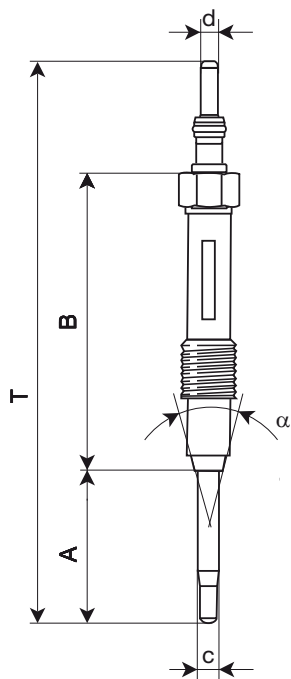

T	109,5
A	30,2
B	57
c	5
d	4
$\alpha$	63°
	M10X1
	10
V	11
Amp	15
	4"
Nm	10÷12

<b>BOSCH</b>	0250202132
<b>CHAMPION</b>	CH269

			<b>kW</b>	<b>cc</b>	<b>V</b>		
--	--	--	-----------	-----------	----------	--	--

## ALFA ROMEO

### 147

1.9 JTDM 8V	4	88	1910	11	937 A3.000	07/05→
-------------	---	----	------	----	------------	--------

## FIAT

### CROMA (194)

1.9 D Multijet	4	88	1910	11	939A1.000	06/05→
----------------	---	----	------	----	-----------	--------

### STILO

1.9 D Multijet	4	88	1910	11	192 A8.000	09/05→
----------------	---	----	------	----	------------	--------

### DOBLO

1.9 D Multijet	4	88	1910	11	186A9.000	10/05→
----------------	---	----	------	----	-----------	--------

# UC44A

## 062900057304

**NEW**

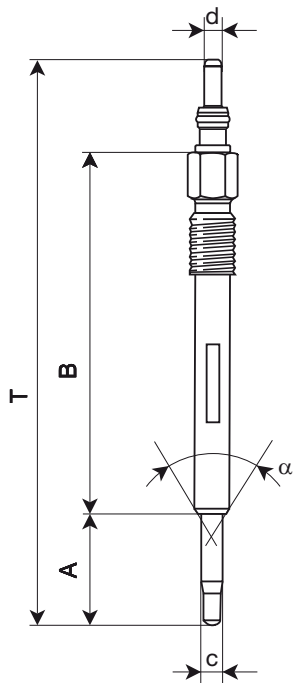

T	130
A	25,5
B	83
c	5
d	4
$\alpha$	63°
	M10X1
	10
V	11,5
Amp	15
	4"
Nm	10÷12



<b>BERU</b>	0100226494 GN055
<b>BOSCH</b>	0250202038
<b>CHAMPION</b>	CH180



**kW**

**cc**

**V**



### CHRYSLER

#### VOYAGER III

2.5 CRD	4	105	2499	11.5	ENC, ENJ	02/00→
2.8 CRD	4	110	2776	11.5	ENR	06/04→

### JEEP

#### CHEROKEE

2.5 CRD	4	105	2499	11.5	R 425 DOHC	09/01→
2.8 CRD	4	110	2776	11.5		11/02→

**UC45A**
**062900058304**

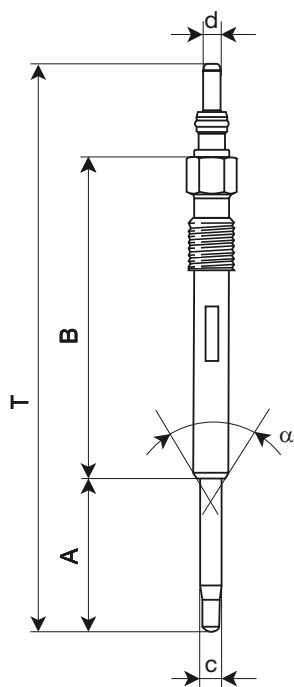
**NEW**

T	125
A	33,6
B	70
c	5
d	4
$\alpha$	63°
	M10X1
	10
V	11
Amp	15
	4"
Nm	10÷12

<b>BERU</b>	0100226338 GN008
<b>BOSCH</b>	0250202102
<b>CHAMPION</b>	CH215
<b>NGK</b>	DP31 Y501U

**kW**
**cc**
**V**

**AUDI**
**A4**

2.5 TDI	6	110	2496	11	AFB, AKN	09/97→11/00
2.5 TDI	6	114	2496	11	AYM	08/01→07/02
2.5 TDI	6	120	2496	11	BCZ, BDG, BFC	07/02→12/04
2.5 TDI	6	120	2496	11	BCZ, BDG	11/04→
2.5 TDI quattro	6	132	2496	11	AFB, AKN	09/97→11/00
2.5 TDI quattro	6	132	2496	11	AKE, BAU, BDH	11/00→12/04

**A4 Avant**

2.5 TDI	6	110	2496	11	AFB, AKN	09/97→09/01
2.5 TDI quattro	6	110	2496	11	AFB, AKN	09/97→09/01
2.5 TDI	6	114	2496	11	AYM	09/01→07/02
2.5 TDI	6	120	2496	11	BCZ, BDG, BFC	07/02→12/04
2.5 TDI	6	120	2496	11	BDG	11/04→05/06
2.5 TDI quattro	6	132	2496	11	AKE, BAU, BDH	09/01→12/04

**A4 Convertible**

2.5 TDI	6	120	2496	11	BCZ, BDG, BFC	08/02→12/05
---------	---	-----	------	----	---------------	-------------



			<b>kW</b>	<b>cc</b>	<b>V</b>		
---	---	---	-----------	-----------	----------	---	---

**AUDI****A6**

2.5 TDI	6	110	2496	11	AFB, AKN	07/97→01/05
2.5 TDI quattro	6	110	2496	11	AFB, AKN	07/97→01/05
2.5 TDI	6	114	2496	11	AYM	08/01→01/05
2.5 TDI	6	120	2496	11	BCZ, BDG, BFC	07/02→01/05
2.5 TDI	6	132	2496	11	AKE, BAU, BDH	02/00→01/05
2.5 TDI quattro	6	132	2496	11	AKE, BAU, BDH	02/00→01/05
2.7 TDI	6	120	2698	11	BSG	11/04→
2.7 TDI	6	132	2698	11	BPP	11/04→

**A6 Avant**

2.5 TDI	6	110	2496	11	AFB, AKN	12/97→01/05
2.5 TDI quattro	6	110	2496	11	AFB, AKN	12/97→01/05
2.5 TDI	6	114	2496	11	AYM	08/01→
2.5 TDI	6	120	2496	11	BCZ, BDG, BFC	07/02→
2.5 TDI quattro	6	132	2496	11	AKE, BAU, BDH	02/00→01/05
2.7 TDI	6	120	2698	11	BSG→4F5028000	03/05→

**A8**

2.5 TDI	6	110	2496	11	AFB, AKN	01/97→04/00
2.5 TDI quattro	6	110	2496	11	AFB, AKN	07/97→04/00
2.5 TDI	6	132	2496	11	AKE	09/00→09/02
2.5 TDI quattro	6	132	2496	11	AKE	09/00→09/02
3.0 TDI quattro	6	171	2967	11	ASB	08/03→
3.3 TDI quattro	8	165	3328	11	AKF	06/00→09/02
4.0 TDI quattro	8	202	3936	11	ASE	03/03→

**ALLROAD**

2.5 TDI quattro	6	120	2496	11	BCZ	05/03→08/05
2.5 TDI quattro	6	132	2496	11	AKE, BAU	05/00→08/05

**SKODA****SUPERB**

2.5 TDI	6	114	2496	11	AYM	02/02→
2.5 TDI	6	120	2496	11	BDG	06/03→

**VOLKSWAGEN****PASSAT**

2.5 TDI	6	110	2496	11	AFB, AKN	07/98→11/00
2.5 TDI Syncro/4motion	6	110	2496	11	AFB, AKN	12/98→11/00
2.5 TDI	6	110	2496	11	AFB, AKN	11/00→05/05
2.5 TDI 4motion	6	110	2496	11	AFB, AKN	11/00→05/05



**VOLKSWAGEN**

2.5 TDI	6	120	2496	11	BDG	05/03→05/05
2.5 TDI 4motion	6	132	2496	11	BAU, BDH	01/03→05/05

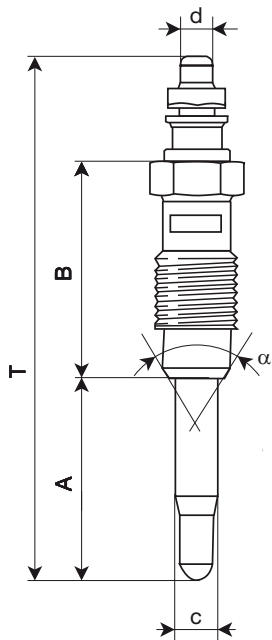
**UX7A**
**061830166304**

T	77
A	29,3
B	31,7
c	6,1
d	M5x0,8
$\alpha$	63°
	M12X1,25
	12
V	11
Amp	13
	5,5"
Nm	15÷20



<b>BERU</b>	0100221141 657MJ GV657
<b>BOSCH</b>	0250201012 0250201014 0250201034 0250201947
<b>CHAMPION</b>	CH70
<b>NGK</b>	Y909R

**kW**
**cc**
**V**

**ALFA ROMEO**
**164**

2.5 TD

4

84

2500

11

VM 84 A

06/87→09/92

**ROVER**
**800 (XS)**

825 D/SD (XS)

4

87

2500

11

425 SL1RR, 492 4 SHIRG

01/90→11/91

# UX8A

062500000304

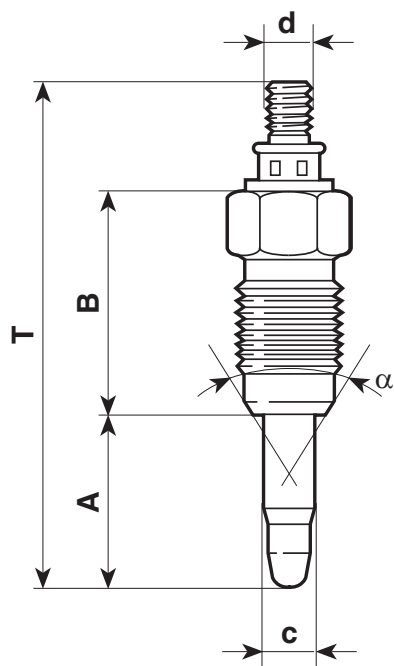

T	59
A	21
B	25,5
c	6,1
d	M5
$\alpha$	63°
	M12X1,25
	12
V	11
Amp	15
	8"
Nm	15÷20



<b>BERU</b>	GN857
<b>BOSCH</b>	0250201953 0250201004 0250201011 0250201015 0250201021 0250201415 0250201933
<b>CHAMPION</b>	CH160
<b>NGK</b>	Y-918R Y-901R



## AUDI

### 100

2.4 D 10V	5	60	2370	11	AAS	12/90→06/94
-----------	---	----	------	----	-----	-------------

## SEAT

### CORDOBA

1.9 D 8V	4	50	1896	11	1Y	02/93→08/96
1.9 TD 8V	4	55	1896	11	AAZ	02/93→08/96

### IBIZA II

1.9 D 8V	4	50	1896	11	1Y	10/94→08/96
1.9 SDI 8V	4	47	1896	11	AEF	08/96→08/99
1.9 TD 8V	4	55	1896	11	AAZ	03/93→08/96

### TOLEDO I

1.9 D 8V	4	50	1896	11	1Y	05/91→03/99
1.9 TD 8V	4	55	1896	11	AAZ	05/91→03/99

			<b>kW</b>	<b>cc</b>	<b>V</b>		
---	---	---	-----------	-----------	----------	---	---

**SKODA****FELICIA**

1.9 D 8V	4	47	1896	11	AEF	10/95→06/01
----------	---	----	------	----	-----	-------------

**VOLKSWAGEN****GOLF III**

1.9 D 8V	4	48	1896	11	1Y	11/91→08/97
1.9 TD,GTD 8V	4	55	1896	11	AAZ	11/91→08/97

**PASSAT**

1.9 D 8V	4	50	1896	11	1Y	05/89→10/93
1.9 TD 8V	4	55	1896	11	AAZ	03/91→08/96

**POLO**

1.4 D 8V	4	35	1398	11	1W	10/90→09/94
1.9 D 8V	4	47	1896	11	AEF	10/94→10/99

**VENTO**

1.9 D 8V	4	48	1896	11	1Y	11/91→09/98
1.9 TD 8V	4	55	1896	11	AAZ	11/91→09/98

**CADDY**

1.6 D 8V	4	40	1588	11	JK/ME	08/82→07/92
1.9 D 8V	4	47	1896	11	1Y, AEF	11/95→01/04

**CALIFORNIA**

1.9 D 8V	4	44		11	1X	09/90→07/95
1.9 TD 8V	4	50		11	ABL	08/92→03/98
2.4 D 10V	5	57		11	AAB, AJA	09/90→04/98

**CARAVELLE**

1.9 D 8V	4			11		09/90→04/96
2.4 D 10V	5			11		09/90→07/95

**EUROVAN**

2.4 SDi 10V	5	57		11		10/92→
-------------	---	----	--	----	--	--------

**LT28-50**

2.4 D 12V	6	51	2383	11	1S/ACT	07/90→05/96
2.4 TD 12V	6	70	2383	11	ACL	06/92→05/96

**LT 40-55**

2.4 D 12V	6	51	2383	11	1S/ACT	07/90→05/96
2.4 D 12V	6	55	2383	11	CP/DW	01/79→07/92
2.4 TD 12V	6	70	2383	11	ACL	08/92→06/96

**MULTIVAN**

1.9 D 8V	4	44		11	1X	09/90→07/95
1.9 D 8V	4	68		11	ABL	08/92→06/94
1.9 TD 8V	4	50		11	ABL	07/94→04/98

**kW**
**cc**
**V**

**VOLKSWAGEN**

2.4 D 8V	4	57		11	AJA, AAB	09/90→04/98
----------	---	----	--	----	----------	-------------

**TRANSPORTER IV**

1.9 D 8V	4	45	1896	11	1X	07/90→
1.9 TD 8V	4	50	1896	11	ABL	10/92→
2.4 D 10V	5	55	2370	11	AJA	08/97→
2.4 D 10V	5	57	2370	11	AAB	07/90→
2.4 D 10V Syncro	5	57	2370	11	AAB	10/92→

**VOLVO**
**940**

2.4 D 12V	6	60	2383	11	D 24	08/90→12/94
2.4 TD 12V	6	80	2383	11	D 24 T	08/90→12/94
2.4 TD 12V Intercooler	6	90	2383	11	D 24 TIC	08/90→10/98

**960**

2.4 TD 12V Intercooler	6	85	2383	11	D 24 TIC	09/91→07/94
------------------------	---	----	------	----	----------	-------------

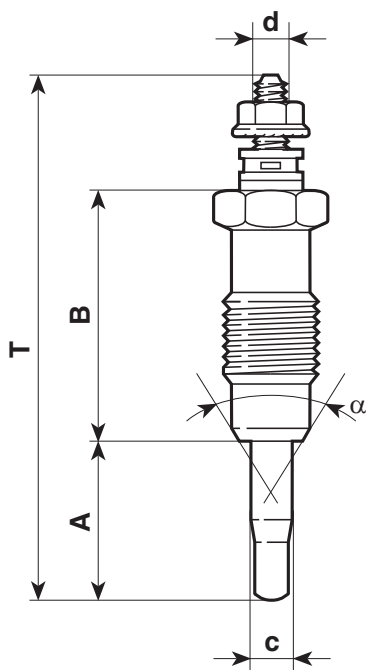
**UX11A**
**062582804304**

T	67
A	21
B	32
c	5
d	M4
$\alpha$	63°
	M12X1,25
	12
V	11,5
Amp	16
	3"
Nm	15÷20



<b>BERU</b>	0100221144
	0100221146
	0100226198
	661MJ
	666MJ
	GN927
<b>BOSCH</b>	GV661
	GV662
	GV666
	0250202001
0250202018	
0250202033	
0250202910	

<b>BOSCH</b>	0250202001
	0250202018
	0250202033
	0250202910

<b>CHAMPION</b>	CH147
-----------------	-------

<b>NGK</b>	DP23
	DP3
	DP33
	Y910J
	Y910R
	Y911J
	Y911R
Y935U	

**CITROËN**
**AX**

1.4 D	4	37	1360	11.5	K9Y (TUD3Y)	08/91→12/97
1.4 D	4	38	1360	11.5	K9A (TUD3)	09/88→06/92

**FIAT**
**DUCATO (230L)**

2.5 D	4	62	2500	11.5	8140.67	03/94→04/02
-------	---	----	------	------	---------	-------------

**FORD**
**ESCORT CLASSIC**

1.8 TD	4	66	1753	11.5	RFD, RFK	10/98→07/00
--------	---	----	------	------	----------	-------------

**ESCORT V**

1.8 D	4	44	1753	11.5	RTE, RTF, RTH	07/90→12/92
-------	---	----	------	------	---------------	-------------

**ESCORT VI**

1.8 D	4	44	1753	11.5	RTE, RTF, RTH	09/92→01/95
1.8 TD	4	66	1753	11.5	RFD, RFK, RFS	02/93→01/95

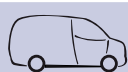
**kW**
**cc**
**V**

**FORD**
**ESCORT VII**

1.8 D	4	44	1753	11.5	RTE, RTF, RTH	01/95→02/99
1.8 TD	4	66	1753	11.5	RFD, RFK	01/95→02/99

**FIESTA III**

1.8 D	4	44	1753	11.5	RTC, RTD, RTG	03/89→12/95
1.8 TD	4	57	1753	11.5		03/93→12/95

**MONDEO I**

1.8 TD	4	65	1753	11.5	RFM, RFN	06/93→08/96
1.8 TD	4	66	1753	11.5	RFM, RFN	10/95→08/96

**ORION III**

1.8 D	4	44	1753	11.5	RTE, RTF, RTH	11/90→12/93
1.8 TD	4	66	1753	11.5	RFD, RFK	03/92→12/93

**SIERRA**

1.8 TD	4	55	1753	11.5	RFA, RFB, RFL	08/88→02/93
--------	---	----	------	------	---------------	-------------

**OPEL**
**MOVANO**

2.5 D	4	59	2499	11.5	S8U 770	01/99→09/00
-------	---	----	------	------	---------	-------------

**PEUGEOT**
**106**

1.4 D	4	37	1361	11.5	K9Y (TUD3Y)	09/92→04/96
-------	---	----	------	------	-------------	-------------

**RENAULT**
**MASTER**

35 2,5 TD	4	69	2499	11.5	8140.27.2500, 8140.27.2510, S9U 714	08/89→07/98
35 2,5 TD	4	69	2499	11.5	8140.27.2500, 8140.27.2510, S9U 714	08/89→07/98

**TRAFIC**

2.5 D	4	51	2445	11.5	S8U 720	05/89→03/01
2.5 D	4	55	2499	11.5	S8U 750, S8U 752, S8	05/89→03/01
2.5 D 4x4	4	55	2499	11.5	S8U 752, S8U 750	05/89→03/01

**ROVER**
**100 (METRO)**

114 D	4	38	1361	11.5	TUD 3	10/92→12/94
-------	---	----	------	------	-------	-------------

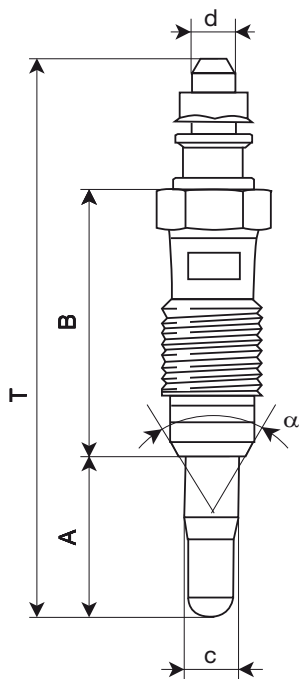

**UX12A**
**062580704304**

T	67
A	20
B	31,7
c	6,1
d	M5X0,8
$\alpha$	63°
	M12X1,25
	12
V	11
Amp	13
	5,5"
Nm	15÷20

<b>BERU</b>	GV631
<b>BOSCH</b>	0250201017 0250202001
<b>CHAMPION</b>	CH79
<b>NGK</b>	Y-907R

**FORD**
**ESCORT '81**

1.6 D	4	40	1608	11	LTA	02/84→02/86
-------	---	----	------	----	-----	-------------

**ESCORT '86**

1.6 D	4	40	1608	11	LTA	02/86→07/90
-------	---	----	------	----	-----	-------------

**ESCORT III**

1.6 D	4	40	1608	11	LTA	02/84→12/85
-------	---	----	------	----	-----	-------------

**ESCORT IV**

1.6 D	4	40	1608	11	LTC	01/86→01/89
-------	---	----	------	----	-----	-------------

**FIESTA II**

1.6 D	4	40	1608	11	LTB	04/84→02/89
-------	---	----	------	----	-----	-------------

**ORION I**

1.6 D	4	40	1608	11	LTA	02/84→03/86
-------	---	----	------	----	-----	-------------

**ORION II**

1.6 D	4	40	1608	11	LTC	12/85→01/89
-------	---	----	------	----	-----	-------------

# UX13A

062583003304

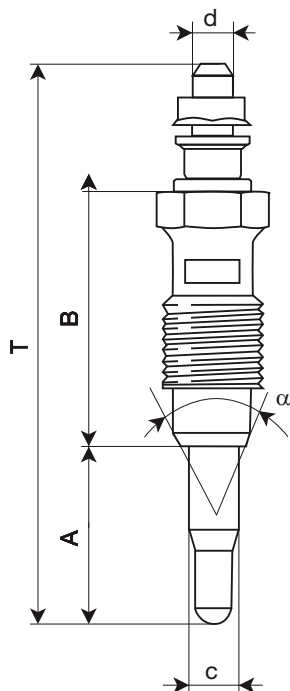

T	70
A	22,3
B	31,7
c	6,1
d	M5X0,8
$\alpha$	63°
	M12X1,25
	12
V	11,5
Amp	14
	5"
Nm	15÷20



<b>BERU</b>	GN858
<b>BOSCH</b>	0250201026 0250201041
<b>CHAMPION</b>	CH176
<b>NGK</b>	Y-916J Y-916R

			<b>kW</b>	<b>cc</b>	<b>V</b>		
--	--	--	-----------	-----------	----------	--	--

## DAEWOO

### KORANDO

2.9 TD 10V	5	88	2874	11,5	MB-OM 601 29TD	01/99→
------------	---	----	------	------	----------------	--------

### MUSSO

2.9 TD 10V	5	88	2874	11,5	MB-OM 601 29TD	01/99→
------------	---	----	------	------	----------------	--------

## MERCEDES

### 190 (W201)

2.0 D 8V	4	53	1997	11,5	OM 601.911	02/89→08/93
2.5 D 10V	5	66	2497	11,5	OM 602.911	02/89→08/93
2.5 TD 10V	5	93	2497	11,5	OM 602.961	02/89→08/93

### C CLASS (W202, S202)

C 200 D 8V	4	55	1997	11,5	OM 601.913	03/93→05/00
------------	---	----	------	------	------------	-------------





### E CLASS (W124, S124)

E 250 TD 10V	5	93	2497	11,5	OM 602.962	06/93→06/95
E 300 TD 12V	6	108	2996	11,5	OM 603.960	06/93→06/95

### G CLASS (W460)

250 GD 10V	5	62	2497	11,5	OM 602.930	02/89→08/92
------------	---	----	------	------	------------	-------------

## → UX13A

  	<b>kW</b>	<b>cc</b>	<b>V</b>		
<b>MERCEDES</b>					
300 GD 12V	6	83	2996	11,5	OM 603.912 03/79→07/93
<b>G CLASS (W461)</b>					
250 GD 10V	5	68	2497	11,5	OM 602.939 02/90→
290 GD/G 290 D	5	70	2874	11,5	OM 602.942 04/92→
G 290 TD 10V	5	88	2874	11,5	OM 602.983 07/97→
<b>G CLASS (W463)</b>					
250 GD 10V	5	69	2497	11,5	OM 602.931 06/90→
300 GD 12V	6	83	2996	11,5	OM 603.931 09/89→
350 G TD 12V	6	100	3449	11,5	OM 603.972 09/91→
<b>S CLASS (W140)</b>					
S 350 TD 12V	6	110	3449	11,5	OM 603.971 01/93→09/95
<b>V CLASS (638/2)</b>					
V 230 TD 8V	4	72	2299	11,5	OM 601.970 09/96→
<b>SPRINTER 2-t</b>					
208 D 8V	4	58	2299	11,5	OM 601.943 02/95→04/00
<b>SPRINTER 3-t</b>					
308 D 8V	4	58	2299	11,5	OM 601.943 02/95→04/00
<b>T1 Series</b>					
208 D 2.3 8V	4	60	2299	11,5	OM 601.940 10/88→02/96
210 D 2.8 10V	5	70	2874	11,5	OM 602.940 11/88→02/96
308 D 2.3 8V	4	60	2299	11,5	OM 601.940 06/89→02.96
308 D 2.3 8V	4	58	2299	11,5	OM 601.940 05/90→02/96
310 D 2.9 10V	5	70	2874	11,5	OM 602.940 06/89→02.96
<b>VITO</b>					
108 D 2.3 8V	4	58	2299	11,5	OM 601.942 02/96→

## OPEL

### KADETT

1.7 TD 8V	4	60		11,5	TC4EE1 OHC Isuzu ( mot 817253→)	02/90→08/91
-----------	---	----	--	------	---------------------------------	-------------

## SSANGYONG

### KORANDO

2.3 D 8V	4	58	2299	11,5	OM 601.940	12/96→
2.9 D 10V	5	72	2874	11,5	MB-OM 662	12/96→

### MUSSO

2.3 D 8V	4	59	2299	11,5	MB-OM 661/OM 601.940	10./95→
2.9 D 10V	5	73	2874	11,5	MB-OM 662	03/96→

# UX14A

062587001304

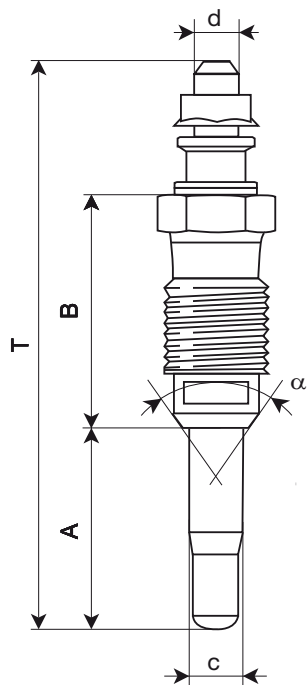

T	67
A	24,3
B	27
c	6,1
d	M5X0,8
$\alpha$	63°
	M12X1,25
	12
V	11
Amp	13
	5,5"
Nm	15÷20



<b>BERU</b>	0100226163 852MJ GV852
<b>BOSCH</b>	0250201029 0250201039 0250201043
<b>CHAMPION</b>	CH173
<b>NGK</b>	DP15 Y913J Y913M



## RENAULT

19							
1.9 D	4	47	1870	11	F8Q 706, F8Q 742		03/91→04/92
1.9 D	4	47	1870	11	F8Q 742		04/92→12/95
1.9 D	4	47	1870	11	F8Q 742		04/92→12/95
1.9 D	4	48	1870	11	F8Q 706, F8Q 742		03/91→12/92
1.9 D	4	48	1870	11	F8Q 706, F8Q 742		03/92→12/95

21							
1.9 D	4	47	1870	11	F8Q 710		03/91→08/94

CLIO							
1.9 D	4	47	1870	11	F8Q 730, F8Q 732		01/91→09/98

RAPID							
1.6 D (F404)	4	40	1596	11	F8M 720, F8M 730, F8M 736, F8M 760		03/86→08/98
1.9 D (F40P, F40N, F40E)	4	47	1870	11	F8Q 722, F8Q 724, F8Q 774, F8Q 776		09/91→03/98

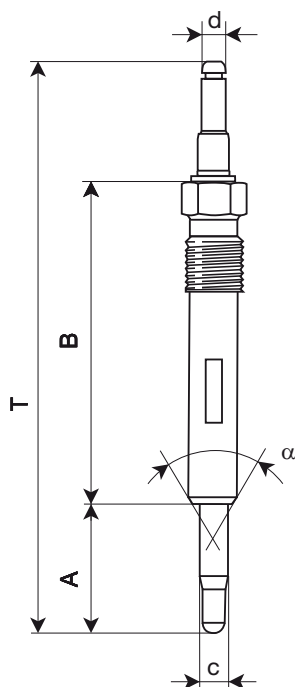
**UX16A**
**062900003304**

T	120
A	27,3
B	67,5
c	6,1
d	5
$\alpha$	63°
	M12X1,25
	12
V	11,5
Amp	14
	5"
Nm	15÷20

<b>BERU</b>	0100226258 GN860
<b>BOSCH</b>	0250201035
<b>CHAMPION</b>	CH175
<b>NGK</b>	DP30 Y930U Y930Y

**MERCEDES BENZ**
**C-CLASS (W202)**

C 220 D	4	55	2155	11.5	OM 604.910 → 021.055	07/96→05/00
C 220 D	4	70	2155	11.5	OM 604.910 → 021.055	08/93→05/00
C 250 D	5	83	2497	11.5	OM 605.910 no immobilizer	05/93→05/00

**E-CLASS (W124)**

E 250 D	5	83	2497	11.5	OM 605.911 no immobilizer	07/93→06/96
E 300 D	6	100	2996	11.5	OM 606.910 no immobilizer	07/93→06/96

**E-CLASS (W210)**

E 220 D	4	70	2155	11.5	OM 604.912 no immobilizer	06/95→07/99
E 300 D	6	100	2996	11.5	OM 606.912 no immobilizer	06/95→06/97
E 300 Turbo-D	6	130	2996	11.5	OM 606.962 no immobilizer	12/96→07/99

# UX17A

062900004304

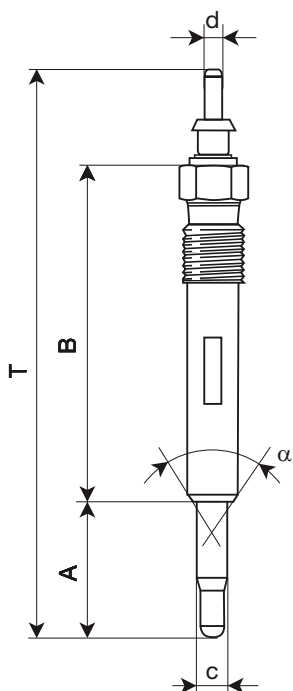

T	114
A	27,3
B	67,5
c	6,1
d	4
$\alpha$	63°
	M12X1,25
	12
V	11,5
Amp	14
	5'
Nm	15÷20



<b>BERU</b>	0100226235 948MJ GN948
<b>BOSCH</b>	0250201038 0250201048
<b>CHAMPION</b>	CH177
<b>NGK</b>	DP16 Y925J Y925R



**kW**

**cc**

**V**



## MERCEDES BENZ

### C-CLASS (W202)

C 220 D	4	55	2155	11.5	OM 604.910 021.056→	07/96→05/00
C 200 D	4	65	1997	11.5	OM 604.915	10/96→05/00
C 220 D	4	70	2155	11.5	OM 604.910 021.056→	08/93→05/00
C 250 D	5	83	2497	11.5	OM 605.910 immobilizer	05/93→05/00
C 250 Turbo-D	5	110	2497	11.5	OM 605.960	10/95→05/00

### E-CLASS (W124)

E 200 D	4	55	1997	11.5	OM 601.912	06/93→06/96
E 250 D	5	83	2497	11.5	OM 605.911 immobilizer	07/93→06/96
E 300 D	6	100	2996	11.5	OM 606.910 immobilizer	07/93→06/96

### E-CLASS (W210)

E 200 D	4	65	1997	11.5	OM 604.917	01/96→03/02
E 220 D	4	55	2155	11.5	OM 604.912	05/96→03/02
E 220 D	4	70	2155	11.5	OM 604.912 immobilizer	06/95→07/99
E 250 D	5	83	2497	11.5	OM 605.912	06/95→07/99
E 250 Turbo-D	5	110	2497	11.5	OM 605.962	06/97→07/99
E 300 D	6	100	2996	11.5	OM 606.912 immobilizer	06/95→06/97



**MERCEDES BENZ**

E 300 Turbo-D	6	130	2996	11.5	OM 606.962 immobilizer	12/96→07/99
---------------	---	-----	------	------	------------------------	-------------

**G-CLASS (W463)**

G 300 TD	6	130	2996	11.5	OM 606.964	08/96→
----------	---	-----	------	------	------------	--------

**S-CLASS (W140)**

S 300 Turbo-D	6	130	2996	11.5	OM 606.961	05/96→10/98
---------------	---	-----	------	------	------------	-------------

S 350 Turbo-D	6	110	3449	11.5	OM 603.971	10/95→10/98
---------------	---	-----	------	------	------------	-------------

# UX18A

## 062900005304

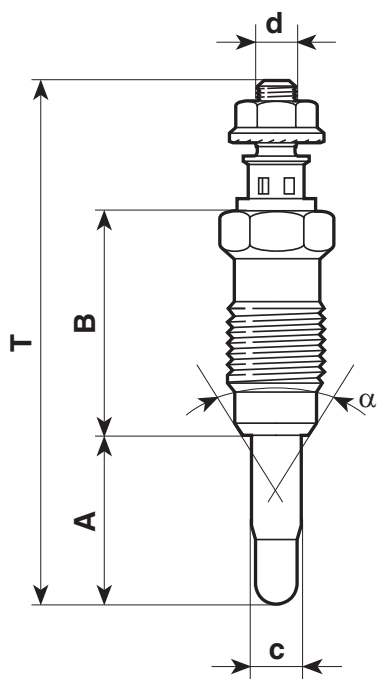

T	63
A	21
B	27
c	6,1
d	M5
$\alpha$	63°
	M12X1,25
	12
V	11
Amp	16
	7"
Nm	15÷20



<b>BERU</b>	844MJ GN959 GV844
<b>BOSCH</b>	0250201050
<b>CHAMPION</b>	CH179
<b>NGK</b>	Y-933J



### MITSUBISHI

#### CARISMA

1.9 TD 8V	4	66	1870	11	F8QT	10/96→09/00
-----------	---	----	------	----	------	-------------

### RENAULT

#### 19

1.9 dT 8V	4	66	1870	11	F8Q 744	04/92→12/95
1.9 TD 8V	4	68	1870	11		09/90→04/92

#### MEGANE I

1.9 dT 8V	4	66	1870	11	F8Q 784/F8Q 786	01/96→
-----------	---	----	------	----	-----------------	--------

#### MEGANE Scenic

1.9 dT 8V	4	66	1870	11	F8Q 784/F8Q 786	01/97→09/99
-----------	---	----	------	----	-----------------	-------------

### VOLVO

#### 440

1.9 TD 8V	4	66	1870	11	D 19 T	07/94→12/96
-----------	---	----	------	----	--------	-------------

#### 460

1.9 TD 8V	4	66	1870	11	D 19 T	07/94→07/96
-----------	---	----	------	----	--------	-------------





**VOLVO**

**S40**

1.9 TD 8V	4	66	1870	11	D 4192 T	07/95→08/99
-----------	---	----	------	----	----------	-------------

**V40**

1.9 TD 8V	4	66	1870	11	D 4192 T	07/95→08/99
-----------	---	----	------	----	----------	-------------

1.9 TD 8V	4	70	1870	11	D 4192 T2	03/99→07/00
-----------	---	----	------	----	-----------	-------------

# UX19A

062900008304

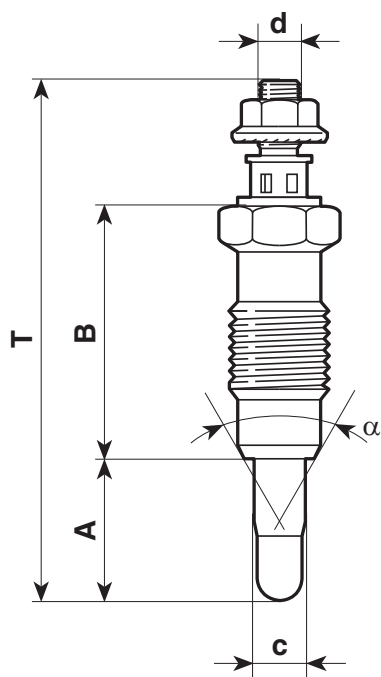

T	63
A	17,3
B	30
c	6,1
d	M5x0,8
$\alpha$	63°
	12
V	11,5
Amp	14
	5"
Nm	15÷20



<b>BERU</b>	0100226248 0100226381 GN022 GN966
<b>BOSCH</b>	0250201049
<b>CHAMPION</b>	CH205
<b>NGK</b>	DP5 Y937J Y937R

			<b>kW</b>	<b>cc</b>	<b>V</b>		
--	--	--	-----------	-----------	----------	--	--

FORD							
ESCORT VII							
1.8 Turbo D	4	51	1753	11.5	RVA		12/95→08/99
FIESTA IV							
1.8 D	4	44	1753	11.5	RTJ, RTK		08/95→04/00
1.8 DI	4	55	1753	11.5	RTN, RTP, RTQ		04/00→01/02
MONDEO II							
1.8 TD	4	66	1753	11.5	RFN		09/96→11/00

MAZDA							
121 III							
1.8 D	4	44	1753	11.5	RTJ, RTK		03/96→

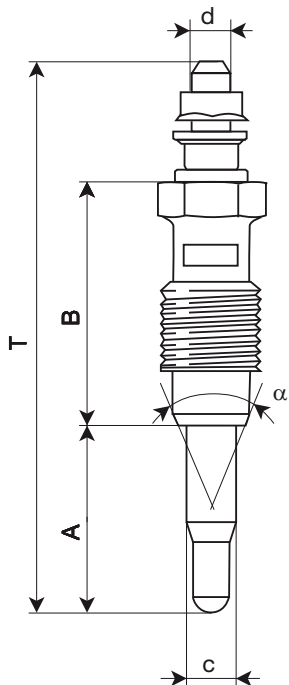
**UX20A**
**062900010304**

T	72
A	24,3
B	31,7
c	6,1
d	M5X0,8
$\alpha$	63°
	M12X1,25
	12
V	11
Amp	13
	5,5"
Nm	15÷20

**BERU**

0100221107	0100221133
0100221145	0100221153
0100221163	0100221164
0100226128	0100226185
0100226186	0100226229
0100226366	

**BOSCH**

0250200069	0250200469
0250201001	0250201005
0250201008	0250201009
0250201019	0250201027
0250201030	0250201033
0250201033	0250201037
0250201039	0250201042
0250201405	0250201945
0250201950	0250201952
0250201953	0250202042

**CHAMPION**

	CH189
<b>NGK</b> DP1	Y1032
Y208T	Y902R
Y914U	Y917U
Y922R	Y923U
Y924U	Y938R

**ALFA ROMEO**
**145**

1.9 TD	4	66	1929	11	AR 33601, AR 67501	10/94→02/99
--------	---	----	------	----	--------------------	-------------

**146**

1.9 TD	4	66	1929	11	AR 33601, AR 67501	12/94→02/99
--------	---	----	------	----	--------------------	-------------

**155**

1.9 TD	4	66	1929	11	AR 67501	04/93→12/97
2.5 TD	4	92	2499	11	VM 07 B, VM 31 B	04/93→04/95

**164**

2.5 TD	4	92	2499	11	VM 08 B, VM 32 B	09/92→04/95
--------	---	----	------	----	------------------	-------------

**BMW**
**3 (E36)**

318tds	4	66	1665	11	M 41 D 18 (Inter.)	01/95→02/98
325td	6	85	2497	11	M 51 D 25	09/91→02/98
325tds	6	105	2503	11	M 51 D 25 (Inter.)	05/93→02/98

**BMW**
**3 Compact (E36)**

318tds	4	66	1665	11	M 41 D 18 (Inter.)	01/95→08/00
--------	---	----	------	----	--------------------	-------------

**3 Touring (E36)**

318tds	4	66	1665	11	M 41 D 18 (Inter.)	01/95→10/99
325tds	6	105	2503	11	M 51 D 25 (Inter.)	01/95→10/99

**5 (E39)**

525 td	6	85	2497	11	M 51 D 25	01/97→06/03
525 tds	6	105	2503	11	M 51 D 25 (Inter.)	01/96→06/03

**5 Touring (E39)**

525 tds	6	105	2503	11	M 51 D 25 (Inter.)	03/97→06/03
---------	---	-----	------	----	--------------------	-------------

**7 (E38)**

725 tds	6	105	2503	11	M 51 D 25 (Inter.)	04/96→11/01
---------	---	-----	------	----	--------------------	-------------

**CHRYSLER**
**VOYAGER I**

2.5 TD	4	87	2500	11	09B, M00	01/92→09/95
--------	---	----	------	----	----------	-------------

**CITROËN**
**EVASION**

1.9 TD	4	66	1905	11	D8B (XUD9TF), DHX (XUD9TF/BTF)	11/94→08/98
1.9 TD	4	66	1905	11	D8B (XUD9TF), DHX (XUD9TF/BTF)	09/98→07/02
1.9 TD	4	68	1905	11	D8B (XUD9TF)	10/95→12/98
2.0 TD	4	68	1998	11		05/97→07/02
2.1 TD	4	80	2088	11	P8C (XUD11BTE)	05/96→07/02

**XANTIA**





1.9 D	4	50	1905	11	DJZ (XUD9Y)	06/94→01/98
1.9 D	4	51	1905	11	D9B (XUD9A/L)	06/94→01/98
1.9 SD	4	55	1905	11	DHW (XUD9SD)	02/96→01/98
1.9 Turbo D	4	66	1905	11	DHX (XUD9TF/BTF), DHY (XUD9TE/Y)	10/94→01/98
2.1 Turbo D 12V	4	80	2088	11	P8C (XUD11BTE)	06/95→01/98

**XANTIA Break**

1.9 SD	4	55	1905	11	DHW (XUD9SD)	04/97→01/98
1.9 Turbo D	4	66	1905	11	D8B (XUD9TF), DHX (XUD9TF/BTF), DHY (XUD9TE/Y)	06/95→01/98
2.1 Turbo D 12V	4	80	2088	11	P8C (XUD11BTE)	06/96→01/98

**XM**

2.1 TD 12V	4	80	2088	11	P8A (XUD11ATE), P8C (XUD11BTE), PHZ (XUD11ATE), PJZ (XUD11ATE)	05/94→10/00
------------	---	----	------	----	--	-------------

 		<b>kW</b>	<b>cc</b>	<b>V</b>		
<b>CITROËN</b>						
2.5 TD	4	95	2446	11	THY (DK5ATE)	05/94→10/00
<b>XM Break</b>						
2.1 D 12V	4	60	2138	11	P9A (XUD11A)	11/91→06/96
2.1 TD 12V	4	80	2088	11	P8A (XUD11ATE), P8C (XUD11BTE), PHZ (XUD11ATE), PJZ (XUD11ATE)	11/91→04/94
2.1 TD 12V	4	80	2088	11	P8C (XUD11BTE), PHZ (XUD11ATE), PJZ (XUD11ATE)	05/94→10/00
2.5 TD	4	95	2446	11	THY (DK5ATE)	05/94→10/00
<b>XSARA</b>						
1.8 D	4	43	1769	11	161A (XUD7), A9A (XUD7)	04/97→09/00
1.8 TD	4	66	1761	11		10/97→09/00
1.9 D	4	50	1905	11	DJY (XUD9A)	04/97→09/00
1.9 SD	4	55	1905	11	DHV (XUD9BSD)	01/98→09/00
1.9 TD	4	66	1905	11	DHY (XUD9TE/Y)	04/97→09/00
<b>XSARA Break</b>						
1.8 D	4	43	1769	11	A9A (XUD7)	10/97→09/00
1.9 D	4	50	1905	11	DJY (XUD9A)	10/97→09/00
1.9 D	4	55	1905	11	DHV (XUD9BSD)	01/98→09/00
1.9 TD	4	66	1905	11	DHY (XUD9TE/Y)	10/97→09/00
<b>XSARA Coupe</b>						
1.9 D	4	50	1905	11	DJY (XUD9A)	02/98→09/00
1.9 TD	4	66	1905	11	DHY (XUD9TE/Y)	02/98→09/00
<b>ZX</b>						
1.8 D	4	44	1769	11	161A (XUD7)	06/93→04/94
1.8 D	4	44	1769	11	161A (XUD7)	05/94→06/97
1.9 D	4	47	1905	11	DJZ (XUD9Y)	05/94→06/97
1.9 D	4	50	1905	11	D9B (XUD9A/U)	06/94→06/97
1.9 TD	4	66	1905	11	DHY (XUD9TE/Y)	07/92→04/94
1.9 TD	4	66	1905	11	DHY (XUD9TE/Y)	05/94→06/97
<b>ZX Break</b>						
1.8 D	4	44	1769	11	161A (XUD7)	10/93→04/94
1.8 D	4	44	1769	11	161A (XUD7)	05/94→10/97
1.9 D	4	47	1905	11	DJZ (XUD9Y)	10/93→04/94
1.9 D	4	47	1905	11	DJZ (XUD9Y)	05/94→10/97
1.9 D	4	50	1905	11	D9B (XUD9A/U)	06/94→10/97
1.9 TD	4	66	1905	11	DHY (XUD9TE/Y)	10/93→04/94
1.9 TD	4	66	1905	11	DHY (XUD9TE/Y)	05/94→10/97
<b>BERLINGO</b>						
1.8 D	4	43	1769	11	A9A (XUD7)	07/98→

			<b>kW</b>	<b>cc</b>	<b>V</b>		
--	---	---	-----------	-----------	----------	---	---

**CITROËN**

1.9 D	4	50	1905	11	D9B (XUD9A/L), DJY (XUD9A)	07/96→
-------	---	----	------	----	----------------------------	--------

**JUMPER**

1.9 D	4	50	1905	11	DJY (XUD9A)	07/99→04/02
1.9 D	4	51	1905	11	D9B (XUD9A/U)	02/94→04/02
1.9 TD	4	66	1905	11	DHX (XUD9TF/BTF)	09/98→04/02
1.9 TD	4	66	1905	11	DHX (XUD9TF/BTF)	03/94→08/98
1.9 TD	4	68	1905	11	D8C (XUD9UTF)	03/94→08/98
1.9 TD	4	68	1905	11	D8C (XUD9UTF)	09/98→04/02
1.9 TD 4x4	4	68	1905	11	D8C (XUD9UTF)	03/94→08/98
1.9 TD 4x4	4	68	1905	11	D8C (XUD9UTF)	09/98→04/02
2.5 D	4	63	2446	11	T9A (DJ5)	03/94→04/02
2.5 D 4x4	4	63	2446	11	T9A (DJ5)	03/00→04/02
2.5 TD	4	76	2446	11	T8A (DJ5T)	03/94→04/02
2.5 TD 4x4	4	76	2446	11	T8A (DJ5T)	08/96→04/02

**JUMPY**

1.9 D	4	51	1905	11	D9B (XUD9A/U)	10/95→04/98
1.9 TD	4	66	1905	11	DHX (XUD9TF/BTF)	10/95→
1.9 TD	4	68	1905	11	D8B (XUD9TF)	04/96→08/98
1.9 TD	4	68	1905	11	D8B (XUD9TF)	09/98→

**DODGE**
**CARAVAN II**

2.5 TD	4	85	2499	11	ENC	01/95→03/01
--------	---	----	------	----	-----	-------------

**FIAT**
**BRAVA**

1.9 D	4	48	1929	11	160 A7.000	10/95→03/96
-------	---	----	------	----	------------	-------------

**BRAVO**

1.9 D	4	48	1929	11	160 A7.000	10/95→03/96
-------	---	----	------	----	------------	-------------

**CROMA (154)**

2500 TDE	4	77	2500	11	8144.97 S	12/91→08/96
----------	---	----	------	----	-----------	-------------

**ELBA**

1.3 D	4	33	1301	11	127 A5.000	04/86→10/92
-------	---	----	------	----	------------	-------------

1.7 D	4	43	1698	11	146 B2.000	04/89→12/96
-------	---	----	------	----	------------	-------------

**PALIO Weekend**

1.7 TD	4	51	1698	11	176 A3.000	04/96→03/01
--------	---	----	------	----	------------	-------------

**PUNTO (176)**

1.7 D	4	42	1698	11	176 B3.000	04/94→09/97
-------	---	----	------	----	------------	-------------

1.7 TD	4	46	1698	11	176 B7.000	09/96→09/99
--------	---	----	------	----	------------	-------------

			<b>kW</b>	<b>cc</b>	<b>V</b>		
--	--	--	-----------	-----------	----------	--	--

**FIAT**

1.7 TD	4	51	1698	11	176 A3.000	01/94→09/96
1.7 TD	4	52	1698	11	176 A5.000	01/94→09/99

**STRADA**

1.7 TD	4	51	1698	11	176 A3.000	06/99→
--------	---	----	------	----	------------	--------

**TEMPRA**

1.9 D	4	48	1929	11	160 A7.000	07/91→08/96
1.9 TD	4	59	1929	11	160 B6.046	07/92→08/96
1.9 TD	4	66	1929	11	160 A6.000, 160 D1.000	05/90→08/96

**TIPO**

1.7 D	4	43	1697	11	149 B4.000	01/88→10/94
1.7 D	4	45	1697	11		01/88→10/95
1.9 D	4	48	1929	11	160 A7.000	07/91→08/96
1.9 TD	4	59	1929	11	160 B6.046	03/92→06/93
1.9 TD	4	66	1929	11	160 A6.000, 160 A6.046, 160 D1.000	09/90→04/95

**ULYSSE**

1.9 TD	4	66	1905	11	DHX (XUD9TF/L)	02/95→08/02
2.1 TD	4	80	2088	11	P8C	03/96→10/99

**DUCATO (230L)**

1.9 D	4	51	1929	11	230 A2.000	03/94→04/02
1.9 TD CAT	4	59	1929	11	230 A4.000	08/94→04/02
1.9 TD	4	60	1929	11	230 A3.000	03/94→04/02
1.9 TD	4	66	1905	11	DHX (XUD9TF/L)	04/98→04/02

**DUCATO (290)**

1.9 D	4	52	1929	11	149 B1.000	07/90→03/94
1.9 TD	4	60	1929	11	280 A1.000	03/89→03/94
2.5 D 4x4	4	55	2500	11	8144.67	07/90→03/94
2.5 TD	4	70	2500	11	8140.27	07/90→03/94
2.5 TD 4x4	4	70	2500	11	8140.27	07/90→03/94

**FIORINO**

1.7 D	4	42	1697	11	146 B2.000	10/93→10/99
1.7 D	4	44	1698	11	149 B3.000	05/88→10/99
1.7 TD	4	46	1698	11	146 D7.000	01/97→05/01

**SCUDO**

1.9 D	4	51	1905	11	D9B	02/96→
1.9 TD	4	66	1905	11	DHX (XUD9TF/L)	02/96→
1.9 TD	4	68	1905	11	D8B	02/98→

			<b>kW</b>	<b>cc</b>	<b>V</b>		
--	--	--	-----------	-----------	----------	--	--

<b>FORD</b>							
<b>SCORPIO I</b>							
2.5 TD	4	68	2498	11	SFA, SFB	09/91→07/93	
2.5 TD	4	85	2500	11	SCB	08/93→09/94	
<b>SIERRA</b>							
2.3 D	4	49	2304	11	YTR	01/87→02/93	

<b>LANCIA</b>							
<b>DEDRA</b>							
1.9 TDS	4	66	1929	11	160 D1.000, 835 A4.000, 835 A4.046	04/89→07/99	
<b>DEDRA SW</b>							
1.9 TDS	4	66	1929	11	160 D1.000, 835 A4.000	07/94→07/99	
<b>ZETA</b>							
2.1 TD	4	80	2088	11	P 8 C	05/96→09/99	

<b>MERCEDES-BENZ</b>							
<b>190 (W201)</b>							
D 2.0	4	53	1997	11	OM 601.911	08/83→08/89	
D 2.5	5	66	2497	11	OM 602.911	04/85→08/93	
<b>SPRINTER 2-t (901, 902)</b>							
212 D	5	90	2874	11	OM 602.980 → 9849	02/95→04/00	
<b>SPRINTER 3-t (903)</b>							
312 D 2.9	5	90	2874	11	OM 602.980	02/95→04/00	
312 D 2.9	5	90	2874	11	OM 602.980 →9849	02/95→04/00	
312 D 2.9 4x4	5	90	2874	11	OM 602.980	05/97→08/02	
<b>SPRINTER 4-t (904)</b>							
412 D	5	90	2874	11	OM 602.980	02/96→05/06	
412 D 4x4	5	90	2874	11	OM 602.980	05/97→05/06	

<b>OPEL</b>							
<b>ASTRA F</b>							
1.7 D	4	42	1700	11	17 D	12/91→09/92	
1.7 D	4	44	1700	11	17 DR	07/92→09/98	
1.7 TD	4	50	1700	11	X 17 DTL	11/94→09/98	
<b>ASTRA G</b>							
1.7 TD	4	50	1700	11	X 17 DTL	09/98→04/05	
<b>FRONTERA</b>							
2.3 TD	4	74	2260	11	23 DTR	03/92→10/98	
<b>KADETT E</b>							
1.7 D	4	42	1700	11	17 D	01/89→07/94	



			<b>kW</b>	<b>cc</b>	<b>V</b>		
---	---	---	-----------	-----------	----------	---	---

**OPEL****OMEGA**

2.3 D	4	54	2260	11	23 YD	09/86→03/94
2.3 TD Interc.	4	74	2260	11	23 DTR	08/88→03/94
2.5 TD	6	96	2497	11	25 DT, X 25 DT, X 25 TD	04/94→07/03

**VECTRA A**

1.7 D	4	42	1700	11	17 D	09/88→09/92
1.7 D	4	44	1700	11	17 DR	07/92→11/95

**ARENA**

2.5 D	4	55	2499	11	S8U 758, S8U 780, S8U 782	03/98→08/01
-------	---	----	------	----	---------------------------	-------------

**CAMPO**

2.5 D	4	56	2499	11	4 JA1	08/91→06/94
2.5 D 4x4	4	56	2499	11	4 JA1	08/91→06/94

**COMBO**

1.7 DI 16V	4	48	1686	11	Y 17 DTL	10/01→
------------	---	----	------	----	----------	--------

**PEUGEOT****205**

1.7 Diesel	4	44	1769	11	161A (XUD7)	07/87→
1.9 Diesel	4	47	1905	11	DJZ (XUD9Y)	10/87→09/98
1.7 TD	4	57	1769	11	A8B (XUD7TE)	01/90→09/98

**306**

1.8 D	4	43	1769	11	A9A (XUD7)	05/93→08/98
1.8 D	4	43	1769	11	A9A (XUD7)	09/98→05/01
1.9 SLD	4	47	1905	11	DJZ (XUD9Y)	06/94→05/01
1.9 D	4	50	1905	11	DJY (XUD9A)	03/97→08/98
1.9 D	4	50	1905	11	DJY (XUD9A)	09/98→04/02
1.9 D	4	55	1905	11	DHV (XUD9BSD)	03/98→04/02
1.9 TD	4	66	1905	11	DHY (XUD9TE)	09/98→04/02
1.9 TD	4	66	1905	11	DHY (XUD9TE)	02/97→08/98

**405**

1.9 D	4	47	1905	11	DJZ (XUD9Y)	08/92→10/95
1.9 D	4	50	1905	11	DJY (XUD9A)	06/94→10/95
1.9 TD	4	66	1905	11	DHY (XUD9TE)	08/92→10/95

**406**

1.9 D	4	55	1905	11	DHW (XUD9SD)	10/96→08/98
1.9 D	4	55	1905	11	DHW (XUD9SD)	09/98→10/04
1.9 TD	4	66	1905	11	DHX (XUD9TE)	01/96→08/98
1.9 TD	4	66	1905	11	DHX (XUD9TE)	09/98→10/04
1.9 TD	4	68	1905	11	DHY (XUD9TE)	01/96→08/98

**kW**
**cc**
**V**

**PEUGEOT**

1.9 TD	4	68	1905	11	DHY (XUD9TE)	09/98→05/04
2.1 TD 12V	4	80	2088	11	P8C (XUD11BTE)	01/96→08/98
2.1 TD 12V	4	80	2088	11	P8C (XUD11BTE)	09/98→10/04

**605**

2.1 D	4	60	2138	11	P9A (XUD11A)	06/89→07/95
2.1 TD 12V	4	80	2088	11	P8C (XUD11BTE) CEE95L3 09/98→	09/98→09/99
2.1 TD 12V	4	80	2088	11	P8C (XUD11BTE) CEE95L3 →08/98	08/94 →08/98
2.1 Turbo Diesel	4	80	2088	11	PHZ (XUD11ATE)	06/89→09/99
2.5 Turbo Diesel	4	95	2446	11	THY (DK5ATE)	07/94→09/99

**806**

1.9 TD	4	66	1905	11	DHX (XUD9TE)	07/95→08/02
1.9 TD	4	68	1905	11	DHY (XUD9TE)	05/97→08/02
2.1 td 12V	4	80	2088	11	P8C (XUD11BTE)	06/96→08/98

**BOXER**





1.9 D	4	50	1905	11	DJY (XUD9A)	07/99→04/02
1.9 D	4	51	1905	11	D8C (XUD9AU)	03/94→06/95
1.9 D	4	51	1905	11	D8C (XUD9AU)	07/95→08/98
1.9 D	4	51	1905	11	D8C (XUD9AU)	09/98→04/02
1.9 TD	4	66	1905	11	DHY (XUD9TE)	08/94→08/98
1.9 TD	4	66	1905	11	DHY (XUD9TE)	09/98→04/02
1.9 TD	4	68	1905	11	D8C (XUD9UTF)	03/94→08/98
1.9 TD	4	68	1905	11	D8C (XUD9UTF)	09/98→04/02
1.9 TD 4x4	4	68	1905	11	D8C (XUD9UTF)	07/96→08/98
1.9 TD 4x4	4	68	1905	11	D8C (XUD9UTF)	09/98→04/02
2.5 D	4	63	2446	11	T9A (DJ5)	03/94→04/02
2.5 D 4x4	4	63	2446	11	T9A (DJ5)	07/99→04/02
2.5 TD	4	76	2446	11	T8A (DJ5T)	03/94→04/02
2.5 TD 4x4	4	76	2446	11	T8A (DJ5T)	07/96→04/02

**EXPERT**

1.9 D	4	51	1905	11	D9B (XUD9AU)	02/96→
1.9 TD	4	66	1905	11	DHX (XUD9TE)	02/96→
1.9 TD	4	68	1905	11	D8B (XUD9TE)	02/96→

**J5**

1.9 D	4	51	1905	11	D9B (XUD9A)	10/90→
2.5 D 4x4	4	54	2500	11	CRD93 (U25/661)	10/90→
2.5 TD	4	70	2500	11	CRD93LS (U25/673)	10/90→
2.5 TD 4x4	4	70	2500	11	CRD93LS (U25/673)	10/90→

			kW	cc	V		
<b>PEUGEOT</b>							
2.5 D		4	54	2498	11	CRD93 (U25/661)	09/81→09/90
<b>PARTNER</b>							
1.8 D		4	43	1769	11	A9A (XUD7)	06/96→
1.9 D		4	51	1905	11	DJY (XUD9A)	06/96→

<b>RENAULT</b>							
<b>21</b>							
2.1 D 4x4		4	48	2068	11	J8S 704	10/88→05/92
2.1 D		4	49	2068	11	J8S 704	06/86→08/94
2.1 D		4	51	2068	11	J8S 784	02/92→09/95
2.1 D		4	53	2068	11	J8S 600, J8S 740	05/89→06/94
2.1 Turbo-D		4	65	2068	11	J8S 714, J8S 786, J8S 788	03/86→06/94
<b>CLIO</b>							
1.9 D		4	40	1870	11	F8Q 678	01/97→09/98
<b>ESPACE</b>							
2.1 TD		4	65	2068	11	J8S 610, J8S 772, J8S 776, J8S 778	01/91→10/96
2.1 TD		4	66	2068	11	J8S 612	11/94→10/96
<b>SAFRANE</b>							
2.1 dT		4	65	2068	11	J8S 760	11/93→07/96
2.5 dT		4	83	2500	11	S8U 762, S8U 763	12/92→07/96
<b>MASTER</b>							
28-35 2.1 D		4	44	2068	11	J8S 330	01/86→07/98
28-35 2,5 D		4	55	2499	11	S8U 742	08/89→07/98
28-35 2,5 TD		4	72	2499	11	8140.27.2580	08/89→07/98
28-35 2.5 D		4	55	2499	11	S8U 742	08/89→07/98
28-35 2,5 TD		4	72	2499	11	8140.27.2580	08/89→07/98
28-35 2.5 D		4	52	2445	11	8140.61.2300, S8U 731	09/80→07/98
<b>TRAFIC</b>							
2.1 D		4	43	2068	11	852 750	05/89→06/94
2.1 D		4	47	2068	11	J8S 620, J8S 758	06/94→10/97
2.5 D		4	55	2499	11	Sofim-8140.67.2500	05/89→03/01
2.5 D 4x4		4	55	2499	11	Sofim-8140.67.2580	05/89→03/01

<b>ROVER</b>							
<b>200</b>							
218 D		4	52	1905	11		09/91→10/95
218 TD		4	65	1769	11	XUD 7TE	09/91→10/95
<b>400</b>							
418 D		4	49	1905	11		09/91→04/95

			<b>kW</b>	<b>cc</b>	<b>V</b>		
--	---	---	-----------	-----------	----------	---	---

**ROVER**

418 TD	4	65	1769	11	XUD 7TE	09/91→11/98
--------	---	----	------	----	---------	-------------

**800 (XS)**

825 D/SD (XS)	4	87	2500	11	425 SL1RR, 492 4 SHIRG	12/91→04/95
---------------	---	----	------	----	------------------------	-------------

825 SD	4	87	2500	11	425 SL1RR, 492 4 SHIRG	09/93→04/95
--------	---	----	------	----	------------------------	-------------

**MAESTRO**

2.0 D	4	44	1994	11		09/90→10/92
-------	---	----	------	----	--	-------------

2.0 TD	4	60	1994	11	BB	09/90→01/95
--------	---	----	------	----	----	-------------

**MONTEGO**

2.0 D Turbo	4	60	1996	11	BB	10/88→10/95
-------------	---	----	------	----	----	-------------

**SEAT**
**IBIZA I**

1.7 D	4	42	1714	11	022 A.5000	08/90→05/93
-------	---	----	------	----	------------	-------------

**MALAGA**

1.7 D	4	40	1714	11	022 A.5000	05/85→12/93
-------	---	----	------	----	------------	-------------

1.7 D	4	42	1714	11	022 A.5000	05/90→12/93
-------	---	----	------	----	------------	-------------

**SUZUKI**
**BALENO**

1.9 TD	4	55	1905	11		04/98→05/02
--------	---	----	------	----	--	-------------

**SAMURAI**

1.9 TD	4	46	1905	11	XUD9	11/98→
--------	---	----	------	----	------	--------

**VITARA**

1.9 D	4	50	1905	11	XUD9A	01/95→03/98
-------	---	----	------	----	-------	-------------

1.9 D	4	50	1905	11	XUD9A	09/98→
-------	---	----	------	----	-------	--------

1.9 D	4	55	1905	11	XUD9SD	08/96→03/99
-------	---	----	------	----	--------	-------------

**VAUXHALL**
**ARENA**

2.5 D	4	55	2499	11	S8U 758, S8U 780, S8U 782	03/98→11/99
-------	---	----	------	----	---------------------------	-------------

**ASTRA Mk III**

1.7 D	4	42	1699	11	17 D	12/91→02/98
-------	---	----	------	----	------	-------------

1.7 D	4	44	1699	11	17 DR	09/91→12/94
-------	---	----	------	----	-------	-------------

**ASTRA Mk IV**

1.7 TD	4	50	1700	11	X 17 DTL	09/98→08/00
--------	---	----	------	----	----------	-------------

**CAVALIER Mk III**

1.7 D	4	42	1699	11	17 D	09/88→09/92
-------	---	----	------	----	------	-------------

1.7 D	4	44	1700	11	17 DR	07/92→11/95
-------	---	----	------	----	-------	-------------

			<b>kW</b>	<b>cc</b>	<b>V</b>		
--	--	--	-----------	-----------	----------	--	--

**VAUXHALL**

**FRONTERA**

2.3 TD	4	74	2260	11	23 DTR	03/92→10/98
--------	---	----	------	----	--------	-------------

**OMEGA**

2.5 TD	6	96	2497	11	25 DT, X 25 DT	04/94→02/01
--------	---	----	------	----	----------------	-------------

**BRAVA**

2.5 D	4	56	2499	11	4 JA1	08/91→06/94
-------	---	----	------	----	-------	-------------

2.5 D 4x4	4	56	2499	11	4 JA1T	06/90→06/94
-----------	---	----	------	----	--------	-------------

2.5 TD	4	56	2499	11	4 JA1T	07/94→
--------	---	----	------	----	--------	--------

2.5 TD 4x4	4	56	2499	11	4 JA1T	07/94→
------------	---	----	------	----	--------	--------

**COMBO**

1.7 DI 16V	4	48	1686	11	Y 17 DTL	09/01→
------------	---	----	------	----	----------	--------

**MOVANO**

2.5 D	4	59	2499	11	S8U 770	10/98→09/00
-------	---	----	------	----	---------	-------------

2.8 DTI	4	84	2799	11	S9W 702	10/98→10/01
---------	---	----	------	----	---------	-------------

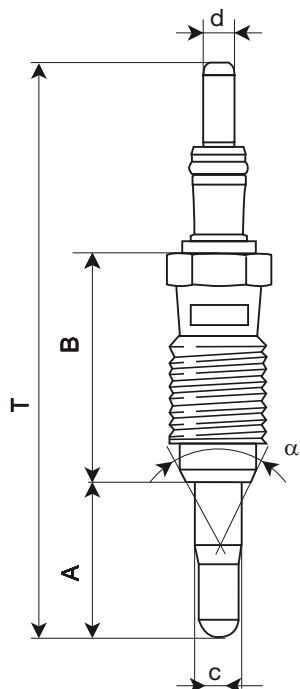
**UX21A**
**062900011304**

T	75,2
A	20,3
B	30
c	6,1
d	4
$\alpha$	63°
	M12X1,25
	12
V	11
Amp	13
	5,5'
Nm	15÷20



<b>BERU</b>	0100226391
	GN030
<b>BOSCH</b>	0250201053
<b>CHAMPION</b>	CH209

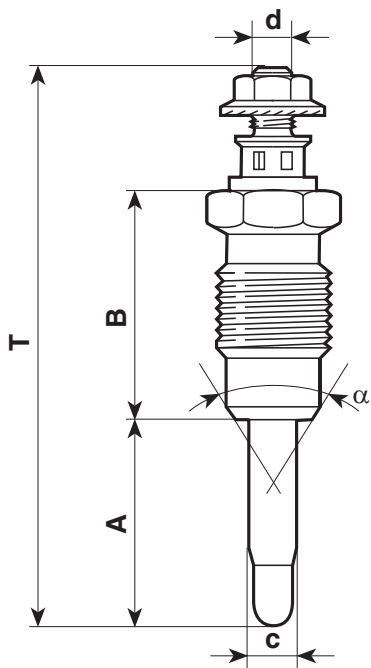

FIAT							
PALIO Weekend							
Model	Cyl	kW	cc	V	Code	Start	End
1.9 D	4	46	1910	11	223 A6.000	03/01	→
PUNTO (188)							
1.9 DS 60	4	44	1910	11	188 A3.000	09/99	→
STRADA							
1.9 D	4	46	1910	11	223 A6.000	12/00	→
DOBLO							
1.9 D	4	46	1910	11	223 A6.000	03/01	→
DOBLO Cargo							
1.9 D	4	46	1910	11	223 A6.000	03/01	→

**UX22A**
**062900016304**

T	70
A	26
B	29
c	5
d	M4
$\alpha$	63°
	M12X1,25
	12
V	11
Amp	15
	5"
Nm	15÷20

<b>BERU</b>	0100226299 GN991
<b>BOSCH</b>	0250202024 0250202035
<b>CHAMPION</b>	CH206
<b>NGK</b>	DP19 Y927J Y927R

**RENAULT**
**CLIO**

1.9 D	4	48	1870	11	F8Q 730, F8Q 732	01/91→09/98
-------	---	----	------	----	------------------	-------------

**MEGANE**

1.9 D	4	47	1870	11	F8Q 620, F8Q 624	01/96→
-------	---	----	------	----	------------------	--------

**MEGANE Scenic**

1.9 D	4	47	1870	11	F8Q 620, 624	03/97→09/99
-------	---	----	------	----	--------------	-------------

**RAPID**

1.9 D (F40R)	4	40	1870	11	F8Q 640, F8Q 682	09/94→03/98
--------------	---	----	------	----	------------------	-------------

**VAUXHALL**
**ARENA**

1.9 D	4	44	1870	11	F8Q 600, F8Q 606	03/98→11/99
-------	---	----	------	----	------------------	-------------

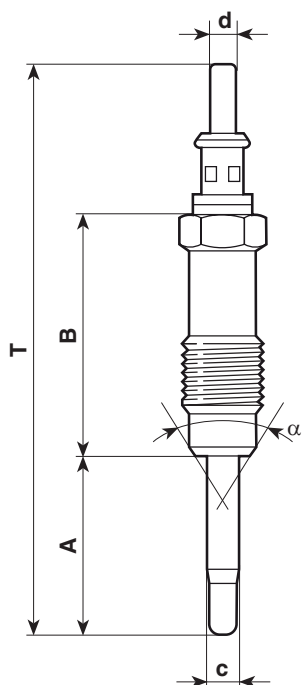
**UX23A**
**062900046304**

T	87
A	28
B	37
c	5
d	4
$\alpha$	63°
	M12X1,25
	12
V	11,5
Amp	15
	4"
Nm	15÷20



<b>BERU</b>	0100226250 GN961
<b>BOSCH</b>	0250202026
<b>CHAMPION</b>	CH204
<b>NGK</b>	Y929U

**kW**
**cc**
**V**

**MERCEDES BENZ**
**E-CLASS (W210)**

E 290 Turbo-D	5	95	2874	11.5	OM 602.982	03/96→07/99
---------------	---	----	------	------	------------	-------------

**SPRINTER 2-t (901, 902)**

210 D	5	75	2874	11.5	OM 602.980	01/97→04/00
212 D	5	90	2874	11.5	OM 602.980 9850→	02/95→04/00

**SPRINTER 3-t (903)**

310 D 2.9	5	75	2874	11.5	OM 602.980	02/95→04/00
312 D 2.9	5	90	2874	11.5	OM 602.980 9850→	02/95→04/00
312 D 2.9 4x4	5	90	2874	11.5	OM 602.980	05/97→08/02
310 D 4x4	5	75	2874	11.5	OM 602.980	05/97→08/02

**SPRINTER 4-t (904)**

410 D	5	75	2874	11.5	OM 602.980	02/96→05/06
410 D 4x4	5	75	2874	11.5	OM 602.980	05/97→05/06
412 D	5	85	2874	11.5	OM 602.980	02/96→05/06
412 D 4x4	5	85	2874	11.5	OM 602.980	05/97→05/06
412 D	5	90	2874	11.5	OM 602.980	02/96→05/06
412 D 4x4	5	90	2874	11.5	OM 602.980	05/97→05/06

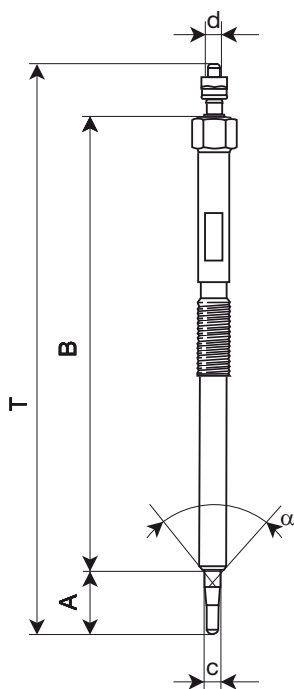

**UX24A**
**062900054304**

T	178,5
A	20,5
B	141
c	4,4
d	M4x0,7
$\alpha$	123°
	M10X1
	12
V	11
Amp	9,2
	6,5"
Nm	12÷15

<b>BERU</b>	0100800031
<b>BOSCH</b>	0250403001
<b>CHAMPION</b>	CH230
<b>NGK</b>	Y519J

**NISSAN**
**ALMERA II**

2.2 Di	4	81	2184	11	YD22DDT	03/00→
2.2 dCi	4	82	2184	11	YD22DDT	09/03→
2.2 dCi	4	100	2184	11	YD22DDTi	09/03→

**ALMERA TINO**

2.2 dCi	4	82	2184	11	YD22DDT	09/03→
2.2 Di	4	84	2184	11	YD22DDTi	08/00→
2.2 dCi	4	100	2184	11	YD22DDTi	09/03→

**PRIMERA**

2.2 Di	4	93	2184	11	YD22DDT	03/02→
2.2 dCi	4	102	2184	11	YD22DDT	04/03→

**X-TRAIL**

2.2 Di 4x4	4	84	2184	11	YD22ETI	07/01→
2.2 dCi 4x4	4	100	2184	11	YD22DDTi	12/03→

**PICK UP**

2.5 Di 4WD	4	98	2488	11	YD25DDTi	03/02→
------------	---	----	------	----	----------	--------

# UX25A

062900056304

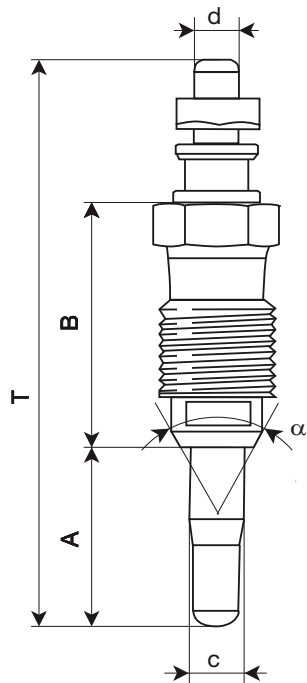

T	62,2
A	20,3
B	26
c	6,1
d	M5X0,8
$\alpha$	63°
	M12X1,25
	12
V	11
Amp	13
	5,5"
Nm	15÷20



<b>BERU</b>	0100221108
0100226164	0100226173
0100226237	601MJ
605MJ	687MJ
689MJ	844MJ
857MJ	GN857
GN959	GV689
GV844	

<b>BOSCH</b>	0250201004
0250201011	0250201015
0250201021	0250201031
0250201031	0250201032
0250201050	0250201415
0250201933	0250201944
0250201953	

**CHAMPION** CH260

<b>NGK</b>	DP2
DP25	Y207T
Y901R	Y918J
Y918R	Y932R
Y933J	Y933R



## AUDI

### 80

1.9 TD	4	55	1896	11	AAZ	09/91→12/94
--------	---	----	------	----	-----	-------------

### 80 Avant

1.9 TD	4	55	1896	11	AAZ	09/91→12/94
--------	---	----	------	----	-----	-------------

### 100

2.4 D	5	60	2370	11	AAS	12/90→06/94
-------	---	----	------	----	-----	-------------

### 100 Avant

2.4 D	5	60	2370	11	AAS	12/90→06/94
-------	---	----	------	----	-----	-------------

## SEAT

### CORDOBA

1.9 D	4	47	1896	11	1Y	01/96→08/96
-------	---	----	------	----	----	-------------

1.9 D	4	50	1896	11	1Y	02/93→08/96
-------	---	----	------	----	----	-------------

1.9 TD	4	55	1896	11	AAZ	02/93→08/96
--------	---	----	------	----	-----	-------------

### IBIZA II

1.9 D	4	47	1896	11	1Y	04/93→08/96
-------	---	----	------	----	----	-------------

1.9 SDI	4	47	1896	11	AEF	08/96→08/99
---------	---	----	------	----	-----	-------------

			<b>kW</b>	<b>cc</b>	<b>V</b>		
---	---	---	-----------	-----------	----------	---	---

**SEAT**

1.9 D	4	50	1896	11	1Y	10/94→08/96
1.9 TD	4	55	1896	11	AAZ	03/93→08/96

**TOLEDO I**

1.9 D	4	47	1896	11	1Y	12/95→03/99
1.9 D	4	50	1896	11	1Y	05/91→03/99
1.9 TD	4	55	1896	11	AAZ	05/91→03/99

**INCA**

1.7 D	4	42	1716	11	AHB	09/96→
1.9 D	4	47	1896	11	1Y	11/95→

**TERRA**

1.3 D	4	33	1272	11	MN	03/90→12/94
1.4 D	4	35	1398	11	1 W	10/90→12/95

**SKODA****FELICIA**

1.9 D	4	47	1896	11	AEF	10/95→06/01
-------	---	----	------	----	-----	-------------

**VOLKSWAGEN****GOLF III**

1.9 D	4	48	1896	11	1Y	11/91→04/99
1.9 TD	4	55	1896	11	AAZ	11/91→04/99

**PASSAT**

1.6 TD	4	59	1588	11	RA, SB	08/88→09/93
1.9 TD	4	55	1896	11	AAZ	03/91→05/97

**POLO**

1.4 D	4	35	1398	11	1W	08/90→09/94
64 1.9 D	4	47	1896	11	AEF	10/94→10/99
1.9 D	4	47	1896	11	AEF	10/99→09/01

**VENTO**

1.9 D	4	48	1896	11	1Y	11/91→09/98
1.9 TD	4	55	1896	11	AAZ	11/91→09/98

**CADDY**

1.9 D	4	47	1896	11	1Y	11/95→01/04
-------	---	----	------	----	----	-------------

**TRANSPORTER IV**

1.9 D	4	44	1896	11	1X	09/90→04/03
1.9 D	4	45	1896	11	1X	07/90→04/03
1.9 TD	4	50	1896	11	ABL	10/92→04/03
2.4 D	5	55	2370	11	AJA	08/97→04/03
2.4 D	5	57	2370	11	AAB	07/90→04/98

**VOLKSWAGEN**

2.4 D Syncro	5	57	2370	11	AAB	10/92→09/98
--------------	---	----	------	----	-----	-------------

**VOLVO**
**940**

2.4 D	6	60	2383	11	D 24	08/90→07/95
2.4 Turbo Diesel	6	80	2383	11	D 24 T	08/90→12/94
2.4 TD Intercooler	6	90	2383	11	D 24 TIC	08/90→10/98

**960**

2.4 TD Interc.	6	85	2383	11	D 24 TIC	09/91→07/94
----------------	---	----	------	----	----------	-------------

**UX26A**

062900059304



**NEW**

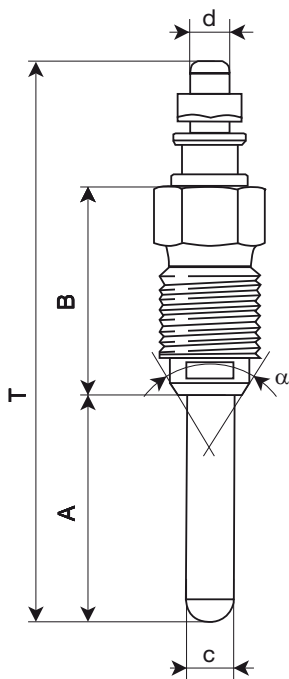

T	70
A	29,5
B	26
c	6,05
d	M5X0,8
$\alpha$	63°
	M12X1,25
	12
V	13,5
Amp	22
	-''
Nm	20÷25

**CHAMPION** CH248



**kW**

**cc**

**V**



**RENAULT**

**MEGANE II**

1.5 dCi	4	76	1461	11	K9K 734 FAP Water Heating Plug	01/07→
1.5 dCi	4	78	1461	11	K9K 734 FAP Water Heating Plug	05/05→

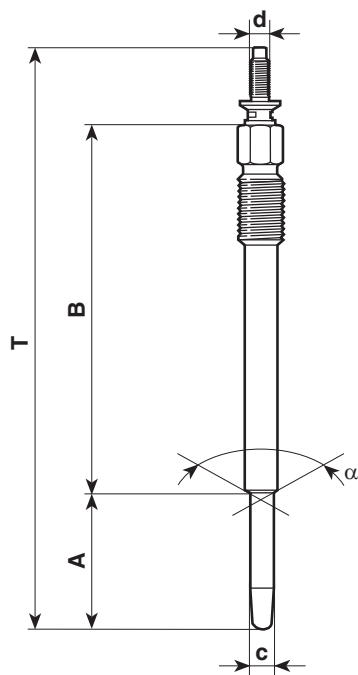
**UY1A**
**062900022304**

T	118,5
A	28
B	75
c	4
d	M4
$\alpha$	123°
	M8X1
	8
V	11
Amp	12
	3"
Nm	8÷12

<b>BERU</b>	0100276004 GN047
<b>BOSCH</b>	0250204001
<b>CHAMPION</b>	CH200
<b>NGK</b>	YE04

**CITROËN**
**C1**

1.4 HDi	4	40	1398	11	DV4D	06/05→
---------	---	----	------	----	------	--------

**C2**

1.4 HDi	4	50	1398	11	8HX (DV4TD)	09/03→
---------	---	----	------	----	-------------	--------

**C3**

1.4 HDi	4	50	1398	11	8HX (DV4TD)	02/02→
---------	---	----	------	----	-------------	--------

1.4 16V HDi	4	66	1398	11	8HY (DV4TED4)	02/02→
-------------	---	----	------	----	---------------	--------

**C3 Pluriel**

1.4 HDi	4	50	1398	11	8HX (DV4TD)	04/04→
---------	---	----	------	----	-------------	--------

**C4**

1.6 HDi	4	66	1560	11	9HX (DV6ATED4)	11/04→
---------	---	----	------	----	----------------	--------

1.6 HDi	4	80	1560	11	9HY (DV6TED4), 9HZ-DV6TED4, DV6TED4	11/04→
---------	---	----	------	----	-------------------------------------	--------

**C4 Coupe**

1.6 HDi	4	66	1560	11	9HX (DV6ATED4)	11/04→
---------	---	----	------	----	----------------	--------

1.6 HDi	4	80	1560	11	9HY (DV6TED4), 9HZ-DV6TED4, DV6TED4	11/04→
---------	---	----	------	----	-------------------------------------	--------

			<b>kW</b>	<b>cc</b>	<b>V</b>		
---	---	---	-----------	-----------	----------	---	---

**CITROËN****C5**

1.6 HDi	4	80	1560	11	DV6TED4	09/04→
---------	---	----	------	----	---------	--------

**C5 Break**

1.6 HDi	4	80	1560	11	DV6TED4	09/04→
---------	---	----	------	----	---------	--------

**XSARA**

1.4 HDi	4	50	1398	11	8HX (DV4TD)	01/03→03/05
---------	---	----	------	----	-------------	-------------

**XSARA Break**

1.4 HDi	4	50	1398	11	8HX (DV4TD)	01/03→08/05
---------	---	----	------	----	-------------	-------------

**XSARA Coupe**

1.4 HDi	4	50	1398	11	8HX (DV4TD)	01/03→03/05
---------	---	----	------	----	-------------	-------------

**XSARA PICASSO**

1.6 HDi	4	66	1560	11		09/05→
---------	---	----	------	----	--	--------

1.6 HDi	4	80	1560	11	DV6TED4	05/04→
---------	---	----	------	----	---------	--------

**FORD****FIESTA V**

1.4 TDCi	4	50	1399	11	F6JA, F6JB	11/01→
----------	---	----	------	----	------------	--------

1.6 TDCi	4	66	1560	11	HHJA, HHJB	11/04→
----------	---	----	------	----	------------	--------

**FOCUS II**

1.6 TDCi	4	66	1560	11	HHDA, HHDB	01/05→
----------	---	----	------	----	------------	--------

1.6 TDCi	4	80	1560	11	G8DA, G8DB	11/04→
----------	---	----	------	----	------------	--------

**FOCUS C-MAX**

1.6 TDCi	4	66	1560	11	HHDA, HHDB	02/05→03/07
----------	---	----	------	----	------------	-------------

1.6 TDCi	4	80	1560	11	G8DA, G8DB	10/03→03/07
----------	---	----	------	----	------------	-------------

**FUSION**

1.4 TDCi	4	50	1399	11	F6JA, F6JB	08/02→
----------	---	----	------	----	------------	--------

1.6 TDCi	4	66	1560	11	HHJA, HHJB	11/04→
----------	---	----	------	----	------------	--------

**MAZDA****2**

1.4 CD	4	50	1399	11	F6JA, F6JB	04/03→
--------	---	----	------	----	------------	--------

**3**

1.6 DI Turbo	4	80	1560	11	Y601	06/04→
--------------	---	----	------	----	------	--------

**PEUGEOT****107**

1.4 HDi	4	40	1398	11		06/05→
---------	---	----	------	----	--	--------

**206**

1.4 Hdi	4	50	1398	11	8HX (DV4TD), 8HZ (DV4TD)	09/01→
---------	---	----	------	----	--------------------------	--------

**kW**
**cc**
**V**

**PEUGEOT**

1.6 HDi 110	4	80	1560	11	9HY (DV6TED4), 9HZ (DV6TED4)	05/04→
-------------	---	----	------	----	------------------------------	--------

**307**

1.4 HDi	4	50	1398	11	8HX (DV4TD), 8HZ (DV4TD)	10/01→
---------	---	----	------	----	--------------------------	--------

1.6 HDi 110	4	80	1560	11	9HY (DV6TED4)	02/04→
-------------	---	----	------	----	---------------	--------

**407**

1.6 HDi 110	4	80	1560	11	9HY (DV6TED4)	05/04→
-------------	---	----	------	----	---------------	--------

**1007**

1.4 HDi	4	50	1398	11	8HX (DV4TD), 8HZ (DV4TD)	04/05→
---------	---	----	------	----	--------------------------	--------

**TOYOTA**
**AYGO**

1.4 HDi	4	40	1398	11		07/05→
---------	---	----	------	----	--	--------

**VOLVO**
**S40**

1.6 D	4	81	1560	11	D 4164 T	01/05→
-------	---	----	------	----	----------	--------

**V50**

1.6 D	4	81	1560	11	D 4164 T	01/05→
-------	---	----	------	----	----------	--------

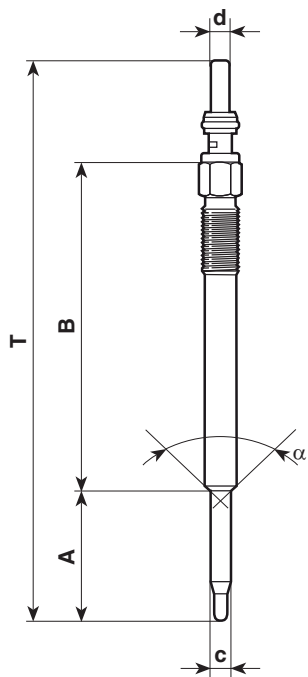

**UY2A**
**062900029304**

**4mm**

T	119
A	28
B	70
c	4
d	4
$\alpha$	93°
	M8X1
	8
V	11
Amp	12
	3"
Nm	8÷10

<b>BERU</b>	0100276007 0100276008 GN053
<b>BOSCH</b>	0250203002
<b>CHAMPION</b>	CH223

**kW**
**cc**
**V**

**FIAT**
**GRANDE PUNTO**

1.3 D Multijet	4	55	1248	11	199 A2.000	10/05→
1.3 D Multijet	4	66	1248	11	199 A3.000	10/05→

**IDEA**

1.3 JTD	4	51	1248	11	188 A9.000	01/04→
---------	---	----	------	----	------------	--------

**PANDA**

1.3 D Multijet	4	51	1248	11	188 A9.000	09/03→
1.3 D Multijet 4x4	4	51	1248	11	188 A9.000	10/04→

**PUNTO (188)**

1.3 JTD 16V	4	51	1248	11	188 A9.000	06/03→
-------------	---	----	------	----	------------	--------

**DOBLO**

1.3 D Multijet	4	62	1248	11	223 A9.000	10/05→
----------------	---	----	------	----	------------	--------

**DOBLO Cargo**

1.3 JTD 16V	4	51	1248	11	188 A9.000	05/04→
1.3 D Multijet	4	55	1248	11	199 A2.000	10/05→

**kW**
**cc**
**V**

**LANCIA**
**MUSA**

1.3 D Multijet	4	51	1248	11	188 A9.000	10/04→
1.3 D Multijet	4	66	1248	11	188 A9.000	09/06→

**YPSILON**

1.3 D Multijet	4	51	1248	11	188 A9.000	10/03→
1.3 D Multijet	4	66	1248	11	188 A9.000	09/06→

**OPEL**
**AGILA**

1.3 CDTI	4	51	1248	11	Z 13 DT	08/03→
----------	---	----	------	----	---------	--------

**ASTRA H**

1.3 CDTI	4	66	1248	11	Z 13 DTH	04/05→
----------	---	----	------	----	----------	--------

**CORSA C**

1.3 CDTI	4	51	1248	11	Z 13 DT	06/03→
----------	---	----	------	----	---------	--------

**CORSA D**

1.3 CDTI	4	55	1248	11	Z 13 DTJ	07/06→
1.3 CDTI	4	66	1248	11	Z 13 DTH	07/06→

**MERIVA**

1.3 CDTI	4	55	1248	11	Z 13 DTJ	09/03→
----------	---	----	------	----	----------	--------

**TIGRA TwinTop**

1.3 CDTI	4	51	1248	11	Z 13 DT	06/04→
----------	---	----	------	----	---------	--------

**COMBO**

1.3 CDTI 16V	4	51	1248	11	Y 13 DT, Z 13 DT	08/05→
--------------	---	----	------	----	------------------	--------

**SUZUKI**
**WAGON R+**

1.3 DDiS	4	51	1248	11	Z13DT	09/03→
----------	---	----	------	----	-------	--------

**VAUXHALL**
**ASTRA MK V**

1.3 CDTI	4	66	1248	11	Z 13 DTH	08/05→
----------	---	----	------	----	----------	--------

**CORSA Mk II**

1.3 CDTI 16V	4	52	1248	11	Z 13 DT	04/04→
--------------	---	----	------	----	---------	--------

**CORSA Mk III**

1.3 CDTI	4	55	1248	11	Z 13 DTJ	07/06→
1.3 CDTI	4	66	1248	11	Z 13 DTH	07/06→

**MERIVA**

1.3 CDTI	4	55	1248	11	Z 13 DTH	09/03→
----------	---	----	------	----	----------	--------



**VAUXHALL**

**TIGRA TwinTop**

1.3 CDTI	4	51	1248	11	Z 13 DT	06/04→
----------	---	----	------	----	---------	--------

# UY3A

## 062900030304



4mm

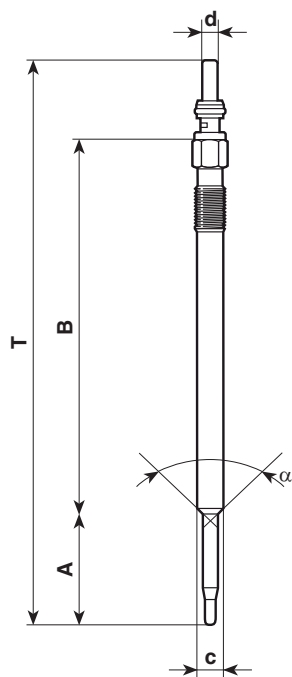

T	151
A	30
B	100
c	4
d	4
$\alpha$	93°
	M9X1
	9
V	11
Amp	18
	7"
Nm	8÷10

<b>BERU</b>	0100276010 0100276015 GN059
<b>BOSCH</b>	0250203001
<b>CHAMPION</b>	CH224



### ALFA ROMEO

#### 147

1.9 JTD 16V	4	103	1910	11	192 A5.000	11/02→
1.9 JTDM 16V	4	110	1910	11	937 A5.000	07/05→

#### 156

1.9 JTD 16V	4	103	1910	11	192 A5.000	11/02→09/05
-------------	---	-----	------	----	------------	-------------

#### 156 Sportwagon

1.9 JTD 16V	4	103	1910	11	192 A5.000	11/02→05/06
1.9 JTD 16V Q4	4	110	1910	11	937 A5.000	07/04→05/06

#### 159



1.9 JTDM 16V	4	110	1910	11	939A2.000	09/05→
2.4 JTDM	5	147	2387	11	939A3.000	09/05→

#### 166

2.4 JTD	5	129	2387	11	841 G.000, 841 H.000	10/03→
---------	---	-----	------	----	----------------------	--------

#### GT

1.9 JTD	4	110	1910	11	937 A5.000	11/03→
---------	---	-----	------	----	------------	--------

			<b>kW</b>	<b>cc</b>	<b>V</b>		
---	---	---	-----------	-----------	----------	---	---

**FIAT****CROMA (194)**

1.9 D Multijet	4	110	1910	11	939A2.000	06/05→
2.4 D Multijet	5	147	2387	11	939A3.000	06/05→

**STILO**

1.9 JTD	4	103	1910	11	192 A5.000	01/04→
1.9 D Multijet	4	110	1910	11	937A5.000	09/05→

**LANCIA****THESIS**

2.4 JTD	5	129	2387	11	841 G.000	05/03→
---------	---	-----	------	----	-----------	--------

**OPEL****ASTRA H**

1.9 CDTI	4	88	1910	11	Z 19 DT	06/04→
1.9 CDTI 16V	4	88	1910	11	Z 19 DTH, Z 19 DTJ	04/04→
1.9 CDTI	4	110	1910	11	Z 19 DTH	09/04→

**SIGNUM**

1.9 CDTI	4	88	1910	11	Z 19 DT	04/04→
1.9 CDTI	4	110	1910	11	Z 19 DTH	04/04→

**VECTRA C**

1.9 CDTI	4	88	1910	11	Z 19 DT	04/04→
1.9 CDTI	4	110	1910	11	Z 19 DTH	04/04→

**ZAFIRA**

1.9 CDTI	4	88	1910	11	Z 19 DT	07/05→
1.9 CDTI	4	110	1910	11	Z 19 DTH	07/05→

**SAAB****9-3**

1.9 TiD	4	88	1910	11	Z19DT	09/04→
1.9 TiD	4	110	1910	11	Z19DTH	09/04→

**VAUXHALL****ASTRA MK V**

1.9 CDTI	4	88	1910	11	Z 19 DT	09/05→
1.9 CDTI 16V	4	88	1910	11	Z 19 DTJ	08/04→
1.9 CDTI	4	110	1910	11	Z 19 DTH	06/04→

**SIGNUM**

1.9 CDTI 16V	4	110	1910	11	Z 19 DTH	04/04→
--------------	---	-----	------	----	----------	--------



**VAUXHALL**

**VECTRA**

1.9 CDTI	4	88	1910	11	Z 19 DT	04/04→
1.9 CDTI 16V	4	110	1910	11	Z 19 DTH	04/04→

**UY4A**
**062900047304**

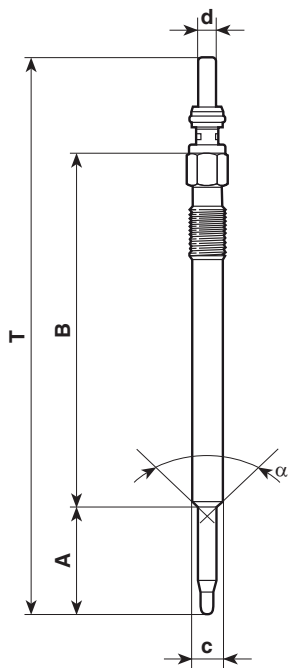
**4mm**

T	126
A	24,5
B	80
c	4
d	4
$\alpha$	93°
	M8X1
	8
V	11
Amp	12
	4''
Nm	8÷10

<b>BERU</b>	8631607 0100276002 0100276005 GN045
<b>CHAMPION</b>	CH240

**CITROËN**
**C6**

2.7 HDi	6	150	2720	11	DT17ED4	09/05→
---------	---	-----	------	----	---------	--------

**JAGUAR**
**S-TYPE (CCX)**

2.7 D	6	152	2720	11		06/04→
-------	---	-----	------	----	--	--------

**PEUGEOT**
**607**





2.7 HDi 24V	6	150	2721	11	DT17TED4	12/04→
-------------	---	-----	------	----	----------	--------

**VOLVO**
**S60**

2.4 D	5	96	2401	11	D 5244 T2	12/01→
2.4 D5	5	120	2401	11	D 5244 T	07/01→

**S80**

2.4 D	5	96	2401	11	D 5244 T2	10/01→07/06
-------	---	----	------	----	-----------	-------------

  	<b>kW</b>	<b>cc</b>	<b>V</b>			
<b>VOLVO</b>						
2.4 D5	5	120	2401	11	D 5244 T	08/01→07/06
<b>V70</b>						
2.4 D	5	96	2401	11	D 5244 T2	12/01→
2.4 D5	5	120	2401	11	D 5244 T	08/01→
2.4 D5 AWD	5	120	2401	11	D 5244 T2	03/03→
2.4 D5	5	136	2401	11	D 5244 T4	12/05→
2.4 D5 AWD	5	136	2401	11	D 5244 T4	12/05→
<b>XC70 CROSS COUNTRY</b>						
2.4 D5 XC AWD	5	120	2401	11	D 5244 T	09/02→
2.4 D5 AWD	5	136	2401	11	D 5244 T4	12/05→
<b>XC 90</b>						
D5	5	120	2401	11	D 5244 T	10/02→

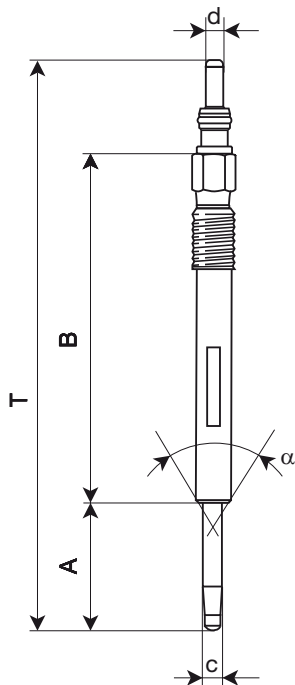

**UY5A**
**062900048304**

**4mm**

T 124

A 27,7

B 75

c 4

d 4

 $\alpha$  123°

M8X1

8

V 11

Amp 10

4,5"

Nm 8÷10

**CHAMPION** CH201

**NGK** YE05

**kW**
**cc**
**V**

**CITROËN**
**C3**

1.6 16V HDi	4	66	1560	11	9HX (DV6ATED4)	10/05→
1.6 16V HDi	4	80	1560	11	DV6TED4	09/05→

**BERLINGO**

1.6 HDi 75	4	55	1560	11	19026	07/05→
1.6 HDi 90	4	66	1560	11	19027	07/05→

**MINI**
**COOPER D**

1.6 D	4	80	1560	11	9HZ (DV6TED4)	03/07→
-------	---	----	------	----	---------------	--------

**COOPER D Clubman**

1.6 D	4	80	1560	11	9HZ (DV6TED4)	10/07→
-------	---	----	------	----	---------------	--------

**PEUGEOT**
**207**

1.4 HDi	4	50	1398	11		02/06→
1.6 HDi	4	66	1560	11	9HX (DV6ATED4)	02/06→



**PEUGEOT**

1.6 HDi	4	80	1560	11	9HY (DV6TED4), 9HZ (DV6TED4)	02/06→
---------	---	----	------	----	------------------------------	--------

**307**

1.6 HDi	4	66	1560	11	9HX (DV6ATED4)	04/05→
---------	---	----	------	----	----------------	--------



**UY6A**

062900060304

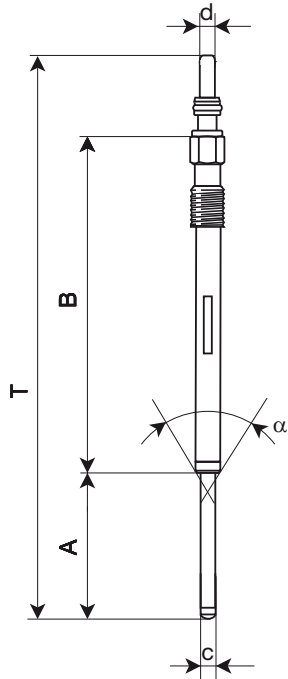

**NEW**  
4mm



T	151
A	39,6
B	90
c	4
d	4
$\alpha$	93°
	M8X1
	8
V	11
Amp	10
	5,5"
Nm	8÷10

**BERU** 0100276003  
GN037

**CHAMPION** CH270



**kW**

**cc**

**V**



**FIAT**

**DUCATO (244)**

2.3 JTD

4

81

2286

11

F1AE0481C

04/02→

**UY7A**
**062900061304**

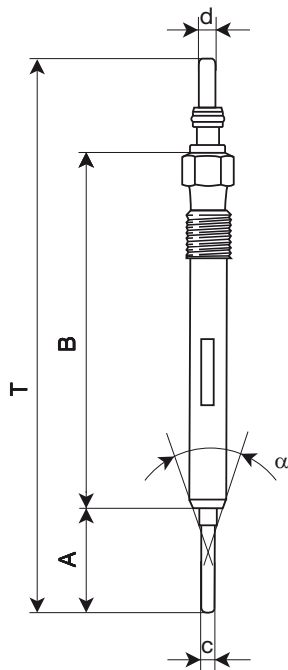
**NEW**
**4mm**

T	126,3
A	24
B	81
c	4
d	4
$\alpha$	63°
	M10X1
	10
V	4,4
Amp	8,5
	1,5''
Nm	8÷10

<b>BERU</b>	0100266014
	0100266016
	0100266020
	GE108
	GE115
<b>CHAMPION</b>	CH705

**kW**
**cc**
**V**

**AUDI**
**A4**

2.7 TDI	6	132	2698	4,4	BPP	01/06→
3.0 TDI quattro	6	150	2967	4,4	BKN	11/04→
3.0 TDI quattro	6	171	2967	4,4	ASB	01/06→

**A4 Avant**

2.7 TDI	6	132	2698	4,4	BPP	01/06→
3.0 TDI quattro	6	150	2967	4,4	BKN	11/04→
3.0 TDI quattro	6	171	2967	4,4	ASB	01/06→

**A4 Convertible**

2.7 TDI	6	132	2698	4,4	BPP	06/06→
3.0 TDI quattro	6	171	2967	4,4	ASB	10/05→

**A5**

2.7 TDI	6	140	2698	4,4		06/07→
3.0 TDI quattro	6	174	2967	4,4		06/07→

**A6**

2.7 TDI quattro	6	120	2698	4,4	BSG	06/05→
2.7 TDI quattro	6	132	2698	4,4		11/04→

			<b>kW</b>	<b>cc</b>	<b>V</b>		
---	---	---	-----------	-----------	----------	---	---

**AUDI**

3.0 TDI quattro	6	155	2967	4,4	BNG	05/04→
3.0 TDI quattro	6	165	2967	4,4	BMK	05/04→

**A6 Avant**

2.7 TDI quattro	6	120	2698	4,4	BSG	06/05→
2.7 TDI	6	132	2698	4,4		03/05→
2.7 TDI quattro	6	132	2698	4,4		03/05→
3.0 TDI quattro	6	155	2967	4,4	BNG	03/05→
3.0 TDI quattro	6	165	2967	4,4	BMK	03/05→

**A8**

3.0 TDI quattro	6	155	2967	4,4	BNG	11/03→
-----------------	---	-----	------	-----	-----	--------

**VOLKSWAGEN****PHAETON**

3.0 V6 TDI 4motion	6	165	2967	4,4	BMK	09/04→
--------------------	---	-----	------	-----	-----	--------

**TOUAREG**

3.0 V6 TDI	6	165	2967	4,4	BKS	11/04→
------------	---	-----	------	-----	-----	--------

# UY8A

## 062900062304



**NEW**  
4mm

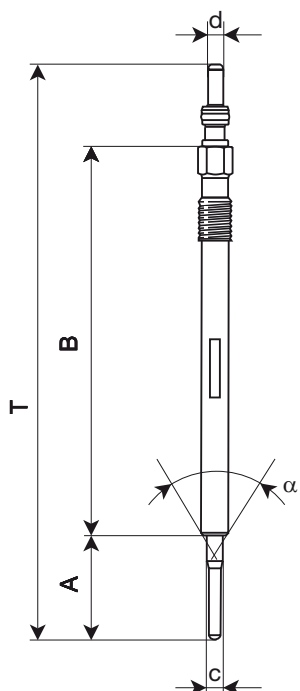

T	147,9
A	26,6
B	100
c	4
d	4
$\alpha$	93°
	M8X1
	8
V	4,4
Amp	8,5
	1,5''
Nm	8÷10

<b>BERU</b>	0100266011 GE105
<b>CHAMPION</b>	CH709



### CHRYSLER

#### 300 C

3.0 CRD	6	160	2987	4,4	M664	09/05→
---------	---	-----	------	-----	------	--------

#### 300 C Touring

3.0 CRD	6	160	2987	4,4	M664	09/05→
---------	---	-----	------	-----	------	--------

### JEEP

#### COMMANDER

3.0 CRD	6	160	2987	4,4		04/06→
---------	---	-----	------	-----	--	--------

#### GRAND CHEROKEE III

3.0 CRD	6	160	2987	4,4		06/05→
---------	---	-----	------	-----	--	--------

### MERCEDES-BENZ

#### A-CLASS (W169)

A 160 CDI	4	60	1991	4,4	OM 640.942	09/04→
A 180 CDI	4	80	1991	4,4	OM 640.940	09/04→
A 200 CDI	4	103	1991	4,4	OM 640.941	09/04→

			<b>kW</b>	<b>cc</b>	<b>V</b>		
--	--	--	-----------	-----------	----------	--	--

**MERCEDES BENZ**

**B-CLASS (W245)**

B 180 CDI	4	80	1991	4,4	OM 640.940	03/05→
B 200 CDI	4	103	1991	4,4	OM 640.941	03/05→

**C-CLASS (W203)**

C 320 CDI	6	165	2987	4,4	OM 642.910	01/05→
-----------	---	-----	------	-----	------------	--------

**CLK (C209)**

320 CDI	6	165	2987	4,4	OM 642.910	01/05→
---------	---	-----	------	-----	------------	--------

**CLS (C219)**

320 CDI	6	165	2987	4,4	OM 642.910	01/05→
---------	---	-----	------	-----	------------	--------

**E-CLASS (W211)**

E 280 CDI	6	140	2987	4,4	OM 642.920	03/05→
E 280 CDI 4-matic	6	140	2987	4,4	OM 642.921	03/05→
E 320 CDI	6	165	2987	4,4	OM 642.920	03/05→
E 320 CDI 4-matic	6	165	2987	4,4	OM 642.910	03/05→
E 420 CDI	8	231	3996	4,4	OM 629.910	01/06→

**GL-CLASS (X164)**

GL 320 CDI	6	165	2987	4,4	OM 642.822	09/06→
GL 420 CDI	8	225	3996	4,4	OM 629.912	09/06→

**M-CLASS (W164)**

ML 280 CDI	6	140	2987	4,4	OM 642.940	07/05→
ML 320 CDI	6	165	2987	4,4	OM 642.940	07/05→

**R-CLASS (W251)**

R 280 CDI	6	140	2987	4,4	OM 642.940	05/06→
R 320 CDI	6	165	2987	4,4	OM 642.950	01/06→

# UZ1A

## 062900031304

CERAMIC

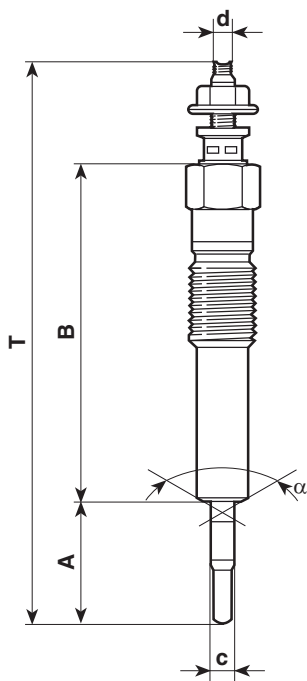

T	87,5
A	18
B	53
c	3,3
d	M4
$\alpha$	120°
	M10X1,25
	12
V	11
Amp	4
	4"
Nm	10÷12



<b>BERU</b>	0100226495 GN103
<b>BOSCH</b>	0250312003
<b>CHAMPION</b>	CH601
<b>NGK</b>	CY03 CY53 DP8



### OPEL

#### ASTRA F

1.7 TDS	4	60	1686	11	17 DT (TC4EE1), X 17 DT (TC4EE1) 956633→	03/92→09/98
---------	---	----	------	----	--	-------------

#### CORSA B

1.5 D	4	37	1488	11	15 D (4EC1)	03/93→09/00
1.5 TD	4	49	1488	11	15 DT (T4EC1), X 15 DT (T4EC1)	03/93→09/00
1.7 D	4	44	1686	11	17 D (4EE1), X 17 D (4EE1)	02/96→09/00

#### VECTRA A

1.7 TD	4	60	1686	11	17 DT (TC4EE1), X 17 DT (TC4EE1)	03/90→11/95
--------	---	----	------	----	----------------------------------	-------------

#### VECTRA B

1.7 TD	4	60	1686	11	X 17 DT (TC4EE1)	10/95→12/98
--------	---	----	------	----	------------------	-------------

#### COMBO

1.7 D	4	44	1686	11	17 D (4EE1), X 17 D (4EE1)	07/94→10/01
-------	---	----	------	----	----------------------------	-------------





**VAUXHALL**

**CORSA**

1.5 D	4	37	1488	11	15 D (4EC1)	03/93→09/00
1.5 TD	4	49	1488	11	15 DT (T4EC1), X 15 DT (T4EC1)	03/93→10/96
1.7 D	4	44	1686	11	17 D (4EE1), X 17 D (4EE1)	02/96→09/00

**VECTRA**

1.7 TD	4	60	1686	11	X 17 DT (TC4EE1)	10/95→11/96
--------	---	----	------	----	------------------	-------------

# UZ2A

## 062900032304

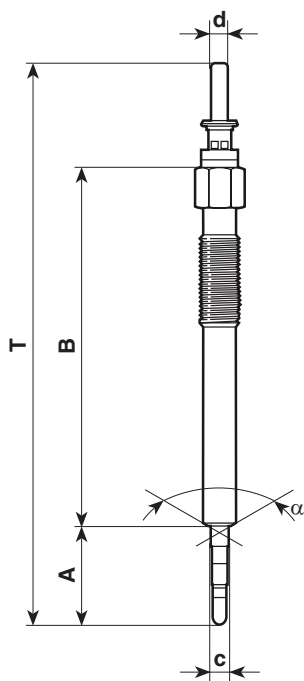

T	144
A	24
B	93
c	4,5
d	4
$\alpha$	120°
	M10X1,25
	12
V	11
Amp	4
	4"
Nm	10÷12

<b>BERU</b>	0100226497 GN104
<b>CHAMPION</b>	CH603
<b>NGK</b>	CZ22 Y541J



### HONDA

#### CIVIC VI

1.7 CTDi	4	74	1686	11	4EE-2	01/02→09/05
----------	---	----	------	----	-------	-------------

### OPEL

#### ASTRA G

1.7 DTI 16V	4	55	1686	11	Y 17 DT	02/00→01/05
1.7 CDTI	4	59	1686	11	Z 17 DTL	04/03→01/05

#### ASTRA H

1.7 CDTI	4	59	1686	11	Z 17 DTL	03/04→
1.7 CDTI	4	74	1686	11	Z 17 DTH	03/04→

#### CORSA C

1.7 DI	4	48	1686	11	Y 17 DTL	09/00→
1.7 DTI	0	55	1686	11	Y 17 DT	09/00→
1.7 CDTI	4	74	1686	11	Z 17 DTH	06/03→

#### CORSA D

1.7 CDTI	4	92	1686	11	Z 17 DTR	07/06→
----------	---	----	------	----	----------	--------

			<b>kW</b>	<b>cc</b>	<b>V</b>		
---	---	---	-----------	-----------	----------	---	---

**OPEL****MERIVA**

1.7 DTI	4	55	1686	11	Y 17 DT	09/03→
1.7 CDTI	4	74	1686	11	Z 17 DTH	09/03→

**COMBO**

1.7 DTI 16V	4	55	1686	11	Y 17 DT	10/01→
-------------	---	----	------	----	---------	--------

**VAUXHALL****ASTRA Mk IV**

1.7 DTI 16V	4	55	1686	11	Y 17 DT	02/00→
1.7 CDTI 16V	4	59	1686	11	Z 17 DTL	04/03→

**ASTRA MK V**

1.7 CDTI	4	59	1686	11	Z 17 DTL	03/04→
1.7 CDTI	4	74	1686	11	Z 17 DTH	03/04→

**CORSA Mk II**

1.7 DI 16V	4	48	1686	11	Y 17 DTL	09/00→
1.7 DTI 16V	4	55	1686	11	Y 17 DT	09/00→
1.7 CDTI 16V	4	74	1686	11	Z 17 DTH	04/04→

**CORSA Mk III**

1.7 CDTI	4	92	1686	11	A 17 DTR	07/06→
----------	---	----	------	----	----------	--------

**MERIVA**

1.7 DTI 16V	4	55	1686	11	Y 17 DT	09/02→
1.7 CDTI 16V	4	74	1686	11	Z 17 DTH	09/03→
1.7 CDTI 16V	4	74	1686	11	Z 17 DTH	04/04→

**COMBO**

1.7 D	4	44	1686	11	17 D (4EE1), X 17 D (4EE1)	07/94→10/01
1.7 DTI 16V	4	55	1686	11	Y 17 DT	10/01→

**UZ3A**

062900044304



CERAMIC

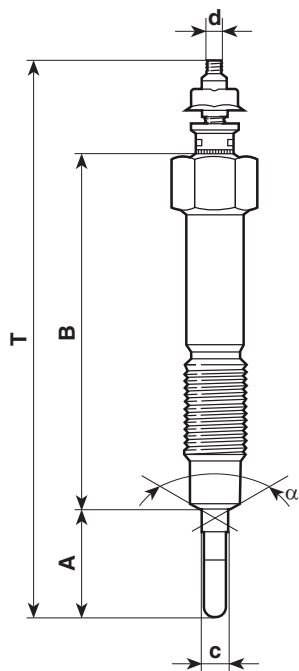

T	96,5
A	19
B	61
c	4,5
d	M4
$\alpha$	122°
	M10X1,25
	12
V	11
Amp	4,5
	4"
Nm	10÷12

<b>BERU</b>	0100226513 GN102
<b>BOSCH</b>	0250312002
<b>CHAMPION</b>	CH600
<b>NGK</b>	CY02 CY52



NISSAN							
ALMERA I							
Model	Cyl	kW	cc	V	Code	Period	
2.0 D	4	55	1974	11	CD20	11/95→07/00	
PRIMERA							
2.0 D	4	55	1974	11	CD20	07/90→01/96	
2.0 TD	4	66	1974	11	CD20T	09/96→07/02	
SUNNY III							
2.0 D	4	55	1974	11	CD20	10/90→03/00	

# UZ4A

## 062900045304

CERAMIC

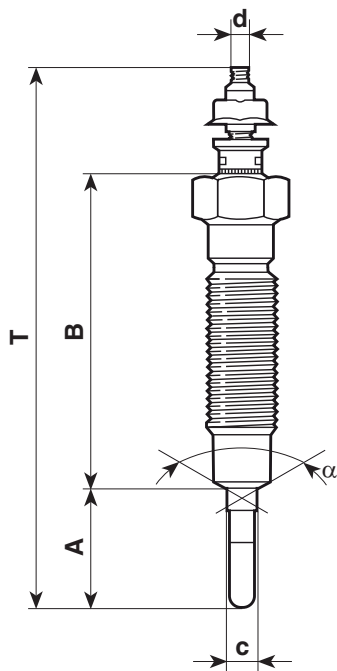

T	81,5
A	18
B	47
c	3,7
d	M4
$\alpha$	120°
	M10X1,25
	12
V	11
Amp	4,5
	4"
Nm	10÷12

<b>BERU</b>	0100226511 GN107
<b>BOSCH</b>	0250312007
<b>CHAMPION</b>	CH602
<b>NGK</b>	CY07 CY57 DP13 DP21



### HYUNDAI

#### GALLOPER II

2.5 TD	4	65	2476	11	D4BA	08/98→
--------	---	----	------	----	------	--------

#### TERRACAN

2.9 CRDi	4	110	2902	11		12/01→
----------	---	-----	------	----	--	--------

2.9 CRDi	4	120	2902	11	J3	11/03→
----------	---	-----	------	----	----	--------

### KIA

#### PREGIO

2.5 Tci D	4	69	2476	11	D4BH	09/02→
-----------	---	----	------	----	------	--------

3.0D	4	66	2987	11		01/98→
------	---	----	------	----	--	--------

### MITSUBISHI

#### GALLOPER

2.5 TD	4	65	2476	11		02/99→
--------	---	----	------	----	--	--------

2.5 TD intercooler	4	73	2476	11	D4BH	02/99→
--------------------	---	----	------	----	------	--------

#### L 200

2.5 TD 4WD	4	85	2477	11	4 D 56 T	09/01→
------------	---	----	------	----	----------	--------



**MITSUBISHI**

2.5 TD 4WD	4	98	2477	11		08/03→
------------	---	----	------	----	--	--------

**L 400**

2500 TD 4x4	4	64	2477	11	4 D 56 T	09/96→
-------------	---	----	------	----	----------	--------

**UZ5A**

**062900055304**

CERAMIC

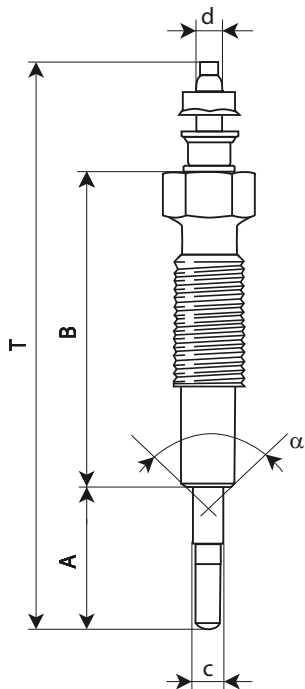

T	85,4
A	21,35
B	48
c	3,7
d	M4X0,7
$\alpha$	120°
	M10X1,25
	12
V	11
Amp	4,5
	4"
Nm	10÷12

<b>BOSCH</b>	9443612053
<b>CHAMPION</b>	CH614

			<b>kW</b>	<b>cc</b>	<b>V</b>		
<b>MAZDA</b>							
<b>323 C IV</b>							
1.7 D		4	41	1720	11	PN54	08/89→07/94
<b>323 III (BF)</b>							
1.7 D		4	40	1720	11	PN27	04/86→05/89
<b>323 S IV (BG)</b>							
1.7 D		4	41	1720	11	PN46, PN54, PN62	08/89→07/94





*Tavole di comparazione*  
*Cross reference guide*  
*Gegenüberstellung*  
*Table de correspondance*  
*Tabla de equivalencias*  
*Tabela de equivalências*  
*Gegenüberstellung*  
*Table de correspondance*  
*Tabla de equivalencias*  
*Tabela de equivalências*



ALFA ROMEO		BERU		BERU	
	MAGNETI MARELLI		MAGNETI MARELLI		MAGNETI MARELLI
46451951	UC11A	0100226229	UX20A	01002266009	UC03F
60596245	UX20A	0100226235	UX17A	01002266011	UY8A
60617002	UC14A	0100226237	UX25A	01002266014	UY7A
60816139	UC11A	0100226238	UC8A	01002266016	UY7A
		0100226246	UC40A	01002266020	UY7A
		0100226248	UX19A	01002276002	UY4A
AUDI		0100226249	UC4A	01002276003	UY6A
059963319A	UC45A	0100226250	UX23A	01002276004	UY1A
059963319E	UY7A	0100226255	UC24A	01002276005	UY4A
N10579802	UC03F	0100226258	UX16A	01002276007	UY2A
N10591602	UC01F	0100226299	UX22A	01002276008	UY2A
N10591603	UC01F	0100226300	UC16A	01002276010	UY3A
		0100226301	UC22A	01002276015	UY3A
BERU		0100226338	UC45A	0100800031	UX24A
8631607	UY4A	0100226343	UC14A	105MN	UX20A
0100221107	UX20A	0100226351	UC29A	151MJ	UX20A
0100221108	UX25A	0100226354	UC37A	161MJ	UX20A
0100221133	UX20A	0100226362	UC26A	601MJ	UX25A
0100221141	UX7A	0100226365	UC18A	603MJ	UX20A
0100221144	UX11A	0100226366	UX20A	604MJ	UX20A
0100221145	UX20A	0100226373	UC31A	605MJ	UX25A
0100221146	UX11A	0100226375	UC30A	607MJ	UX20A
0100221153	UX20A	0100226379	UC17A	613MJ	UX20A
0100221163	UX20A	0100226381	UX19A	633MJ	UX20A
0100221164	UX20A	0100226384	UC22A	636MJ	UX20A
0100226128	UX20A	0100226385	UC27A	651MJ	UX20A
0100226129	UC24A	0100226391	UX21A	657MJ	UX7A
0100226138	UC22A	0100226417	UC28A	661MJ	UX11A
0100226163	UX14A	0100226422	UC33A	663MJ	UX20A
0100226164	UX25A	0100226435	UC42A	666MJ	UX11A
0100226170	UC36A	0100226437	UC32A	687MJ	UX25A
0100226171	UC36A	0100226480	UC32A	689MJ	UX25A
0100226173	UX25A	0100226492	UC41A	691MJ	UX20A
0100226184	UC8A	0100226494	UC44A	719MJ	UX20A
0100226185	UX20A	0100226495	UZ1A	724MJ	UX20A
0100226186	UX20A	0100226497	UZ2A	727MJ	UX20A
0100226188	UC15A	0100226511	UZ4A	783MJ	UC24A
0100226198	UX11A	0100226513	UZ3A	844MJ	UX25A
0100226207	UC10A	0100226522	UC33A	852MJ	UX14A
0100226208	UC9A	0100231114	UC38A	853MJ	UC36A
0100226209	UC9A	0100266008	UC01F	854MJ	UC36A
0100226227	UC31A				

<b>BERU</b>	<b>MAGNETI MARELLI</b>	<b>BERU</b>	<b>MAGNETI MARELLI</b>	<b>BERU</b>	<b>MAGNETI MARELLI</b>
855MJ	UC31A	GN043	UC38A	GV603	UX20A
857MJ	UX25A	GN045	UY4A	GV636	UX20A
905MJ	UC8A	GN046	UC14A	GV642	UX20A
908MJ	UX20A	GN047	UY1A	GV657	UX7A
909MJ	UX20A	GN050	UC42A	GV661	UX11A
912MJ	UC15A	GN053	UY2A	GV662	UX11A
946MJ	UC10A	GN054	UC41A	GV663	UX20A
947MJ	UC9A	GN055	UC44A	GV666	UX11A
948MJ	UX17A	GN059	UY3A	GV689	UX25A
950MJ	UC31A	GN102	UZ3A	GV691	UX20A
964MJ	UC40A	GN103	UZ1A	GV719	UX20A
970MJ	UC4A	GN104	UZ2A	GV724	UX20A
999MJ	UC8A	GN107	UZ4A	GV727	UX20A
GE100	UC01F	GN217	UC21A	GV783	UC24A
GE102	UC02F	GN853	UC36A	GV798	UX20A
GE105	UY8A	GN854	UC36A	GV844	UX25A
GE108	UY7A	GN855	UC31A	GV852	UX14A
GE115	UY7A	GN857	UX25A	GV853	UC36A
GN003	UC17A	GN860	UX16A	GV897	UC38A
GN007	UC14A	GN905	UC8A	GV917	UX20A
GN008	UC45A	GN908	UX20A	GV945	UC36A
GN010	UC18A	GN909	UX20A	GV946	UC10A
GN012	UC37A	GN912	UC15A	GV947	UC9A
GN013	UX20A	GN917	UX20A	GV967	UC38A
GN015	UC39A	GN927	UX11A		
GN016	UC15A	GN939	UC27A	<b>BMW</b>	<b>MAGNETI MARELLI</b>
GN017	UC11A	GN948	UX17A	7786869	UC02F
GN018	UC31A	GN954	UX20A	12231288245	UX20A
GN019	UC30A	GN959	UX25A	12232240255	UX20A
GN022	UX19A	GN961	UX23A	12232241387	UX20A
GN024	UC26A	GN963	UC21A	12232241389	UX20A
GN025	UC16A	GN964	UC40A	12232248059	UC26A
GN026	UC29A	GN966	UX19A	12237786869	UC02F
GN027	UC12A	GN970	UC4A	12239061353	UX20A
GN030	UX21A	GN991	UX22A	12239061354	UX20A
GN033	UC28A	GN992	UC16A		
GN035	UC33A	GN993	UC22A	<b>BOSCH</b>	<b>MAGNETI MARELLI</b>
GN037	UY6A	GN999	UC8A	0250200069	UX20A
GN039	UC36A	GV105	UX20A	0250200469	UX20A
GN041	UC19A	GV362	UC26A	0250201001	UX20A
GN042	UC32A	GV602	UX20A	0250201004	UX25A

BOSCH	MAGNETI MARELLI	BOSCH	MAGNETI MARELLI	BOSCH	MAGNETI MARELLI
0250201005	UX20A	0250202002	UC37A	0250202135	UC41A
0250201008	UX20A	0250202009	UC31A	0250202910	UX11A
0250201009	UX20A	0250202018	UX11A	0250202911	UC31A
0250201010	UC15A	0250202019	UX20A	0250203001	UY3A
0250201011	UX25A	0250202020	UC15A	0250203002	UY2A
0250201012	UX7A	0250202022	UC31A	0250204001	UY1A
0250201014	UX7A	0250202023	UC14A	0250312001	UC01F
0250201015	UX25A	0250202024	UX22A	0250312002	UZ3A
0250201019	UX20A	0250202025	UC8A	0250312003	UZ1A
0250201020	UC15A	0250202026	UX23A	0250312007	UZ4A
0250201021	UX25A	0250202028	UC11A	0250402001	UC01F
0250201027	UX20A	0250202029	UC17A	0250402002	UC02F
0250201029	UX14A	0250202032	UC12A	0250403002	UC03F
0250201030	UX20A	0250202033	UX11A	0250403001	UX24A
0250201031	UX25A	0250202033	UC11A	9443612053	UZ5A
0250201032	UX25A	0250202034	UC4A		
0250201033	UX20A	0250202035	UX22A		
0250201034	UX7A	0250202035	UC21A		
0250201035	UX16A	0250202036	UC19A		
0250201037	UX20A	0250202038	UC44A		
0250201038	UX17A	0250202039	UC16A		
0250201039	UX14A	0250202040	UC24A		
0250201039	UX20A	0250202041	UC18A		
0250201042	UX20A	0250202042	UX20A		
0250201043	UX14A	0250202042	UC16A		
0250201045	UX20A	0250202043	UC28A		
0250201048	UX17A	0250202045	UC17A		
0250201049	UX19A	0250202052	UC38A		
0250201050	UX25A	0250202058	UC38A		
0250201053	UX21A	0250202085	UC10A		
0250201405	UX20A	0250202087	UC9A		
0250201415	UX25A	0250202093	UC36A		
0250201933	UX25A	0250202095	UC38A		
0250201944	UX25A	0250202102	UC45A		
0250201945	UX20A	0250202103	UC26A		
0250201947	UX7A	0250202125	UC35A		
0250201950	UX20A	0250202128	UC29A		
0250201952	UX20A	0250202129	UC30A		
0250201953	UX20A	0250202130	UC27A		
0250201953	UX25A	0250202131	UC22A		
0250202001	UX11A	0250202132	UC43A		
BRISK	MAGNETI MARELLI				
01R447E	UC9A				
01S355E	UC31A				
01S405E	UC8A				
01S412E	UC15A				
01S439E	UC27A				
01S492E	UC16A				
01S503E	UC17A				
01S507E	UC14A				
01S508E	UC45A				
01S510E	UC18A				
01S512E	UC37A				
01S527E	UC12A				
01S533E	UC28A				
01S541E	UC19A				
11S543E	UC38A				
21R136E	UX20A				
21R157E	UX7A				
21R352E	UX14A				
21S357E	UX25A				
21S427E	UX11A				
21S448E	UX17A				
21S461E	UX23A				
21S522E	UX19A				
61S547E	UY1A				

CHAMPION	MAGNETI MARELLI	CHAMPION	MAGNETI MARELLI	CITROËN	MAGNETI MARELLI
CH70	UX7A	CH233	UC30A	59621V	UX20A
CH147	UX11A	CH240	UY4A	59621W	UX11A
CH157	UC10A	CH248	UX26A	59621X	UX25A
CH158	UC9A	CH252	UC32A	59621Y	UX14A
CH166	UC11A	CH258	UC35A	59621Z	UX25A
CH167	UC4A	CH260	UX25A	59622Z	UC15A
CH169	UC8A	CH268	UC41A	59623E	UC12A
CH170	UC12A	CH269	UC43A	59623J	UX20A
CH173	UX14A	CH270	UY6A	5962S8	UX20A
CH175	UX16A	CH271	UC31A	5962T1	UX14A
CH177	UX17A	CH275	UC42A	5962T2	UX25A
CH178	UC24A	CH302	UC38A	5962W2	UC15A
CH180	UC44A	CH600	UZ3A	5962W8	UX20A
CH181	UC14A	CH601	UZ1A	5962W8	UX20A
CH185	UC15A	CH602	UZ4A	MKP00071	UX25A
CH186	UC36A	CH603	UZ2A		
CH189	UX20A	CH614	UZ5A		
CH196	UC22A	CH700	UC01F	<b>DELPHI</b>	MAGNETI MARELLI
CH200	UY1A	CH701	UC02F	HDS216	UX20A
CH201	UY5A	CH702	UC03F	HDS217	UX25A
CH203	UC26A	CH704	UC04F	HDS218	UX20A
CH204	UX23A	CH705	UY7A	HDS267	UX7A
CH205	UX19A	CH709	UY8A	HDS268	UC38A
CH206	UX22A			HDS273	UX11A
CH207	UC16A	<b>CHRYSLER</b>	MAGNETI MARELLI	HDS274	UX20A
CH208	UC40A	05066840AA	UC44A	HDS275	UC38A
CH209	UX21A			HDS295	UX20A
CH215	UC45A	<b>CITROËN</b>	MAGNETI MARELLI	HDS296	UX20A
CH216	UC37A	5960,79	UY5A	HDS303	UC24A
CH217	UC21A	596019	UY1A	HDS337	UX20A
CH218	UC17A	596064	UC41A	HDS339	UX11A
CH219	UC18A	596065	UC41A	HDS341	UX25A
CH222	UC19A	596069	UC15A	HDS342	UX20A
CH223	UY2A	596203	UX20A	HDS342	UC31A
CH224	UY3A	5962008	UX20A	HDS343	UX25A
CH226	UC33A	91536646	UX20A	HDS345	UC10A
CH228	UC39A	96141678	UX20A	HDS346	UC9A
CH229	UC27A	9631658980	UC15A	HDS347	UX14A
CH230	UX24A	59621P	UC40A	HDS348	UX20A
CH231	UC28A	59621Q	UC40A	HDS349	UX20A
CH232	UC29A	59621R	UX20A	HDS350	UC15A
				HDS351	UX20A

<b>DELPHI</b>		<b>DELPHI</b>		<b>DENSO</b>	
HDS354	UX17A	HDS406	UC41A	DG130	UC27A
HDS355	UC8A	HDS408	UC44A	DG137	UC36A
HDS356	UC4A	HDS409	UY3A	DG140	UY4A
HDS358	UC36A	HDS410	UC32A	DG142	UC28A
HDS359	UC36A	HDS413	UC01F	DG144	UC45A
HDS360	UC16A	HDS414	UC03F	DG145	UC26A
HDS361	UC14A	HDS415	UC02F	DG155	UC18A
HDS362	UX19A			DG161	UC40A
HDS363	UX16A	<b>DENSO</b>		DG170	UY3A
HDS364	UC11A	DG001	UX20A	DG171	UY2A
HDS365	UC40A	DG002	UX25A	DG173	UC33A
HDS366	UX22A	DG003	UC15A	DG176	UC44A
HDS367	UC12A	DG004	UX11A	DG177	UC01F
HDS368	UC31A	DG005	UC31A	DG178	UC02F
HDS369	UC15A	DG006	UX14A	DG180	UY5A
HDS370	UC8A	DG007	UX19A	DG181	UC41A
HDS371	UX20A	DG008	UC21A	DG183	UC42A
HDS372	UC26A	DG009	UX22A	DG184	UC39A
HDS373	UX23A	DG101	UC8A	DG190	UC03F
HDS374	UC45A	DG102	UC4A	DG193	UY7A
HDS375	UC37A	DG103	UX25A	DG194	UY8A
HDS376	UC21A	DG104	UC9A	DG195	UY6A
HDS377	UC17A	DG106	UX17A	DG196	UC43A
HDS378	UC18A	DG107	UC31A	DG197	UX24A
HDS379	UC22A	DG109	UC14A	DG202	UX7A
HDS380	UX21A	DG110	UX23A	DG205	UC38A
HDS381	UC39A	DG111	UC37A	DG207	UC38A
HDS382	UC19A	DG112	UC30A	DG217	UC35A
HDS383	UC27A	DG113	UY1A	DG240	UC32A
HDS384	UC28A	DG115	UC24A	DG245	UC35A
HDS385	UC30A	DG116	UC12A	DG300	UZ1A
HDS387	UC39A	DG117	UC17A	DG301	UZ4A
HDS393	UC35A	DG118	UC16A	DG302	UZ2A
HDS396	UC29A	DG119	UX16A	DG304	UZ3A
HDS397	UC33A	DG121	UC22A	DG311	UZ5A
HDS399	UY1A	DG122	UC19A		
HDS401	UZ3A	DG124	UC10A	<b>EYQUEM</b>	
HDS402	UZ1A	DG125	UX20A	CD566R	UX11A
HDS403	UZ4A	DG126	UC29A	CD659R	UX25A
HDS404	UY4A	DG127	UC11A	CD661R	UX25A
HDS405	UZ2A	DG129	UX21A	CD670T	UX20A

EYQUEM	MAGNETI MARELLI	FAI	MAGNETI MARELLI	FAI	MAGNETI MARELLI
CD674V	UX7A	FG133	UX20A	GGP75	UC37A
CL580P	UC9A	FG135	UX20A	GGP77	UC18A
CL586T	UC10A	FG137	UX20A	GGP78	UC17A
DD6120V	UX17A	FG146	UC9A	GGP79	UC16A
DD659R	UX25A	FG147	UX14A	GGP84	UC31A
DD665T	UX14A	FG153	UX11A		
DD671T	UX20A	FG154	UX20A	<b>FIAT</b>	<b>MAGNETI MARELLI</b>
DT584T	UC8A	FG155	UC15A	5951881	UX20A
DT589V	UC15A	GGP01	UX25A	5973752	UX20A
DT592T	UC31A	GGP02	UX25A	5973753	UX20A
		GGP06	UC10A	7702960	UX20A
<b>FAE</b>	<b>MAGNETI MARELLI</b>	GGP11	UX11A	7735920	UX20A
7407	UX20A	GGP18	UX11A	7777837	UX11A
7409	UX14A	GGP30	UC24A	46447610	UC4A
74140	UX20A	GGP32	UX20A	46754154	UC19A
74141	UX25A	GGP33	UC31A	55200817	UC43A
74142	UX11A	GGP34	UX20A	60507123	UX7A
74143	UX7A	GGP36	UC36A	60812292	UX20A
74145	UC31A	GGP38	UC36A	71735462	UC37A
74146	UX22A	GGP40	UC9A	71735464	UX21A
74147	UC8A	GGP42	UX14A	98498630	UX11A
74147	UX16A	GGP43	UC38A	500303569	UC37A
74151	UC15A	GGP44	UX25A	500316493	UC37A
74152	UC14A	GGP46	UX20A	500351992	UY6A
74154	UX23A	GGP47	UC15A	762266740	UX20A
74159	UZ4A	GGP49	UC8A	9616472480	UX20A
74183	UC27A	GGP53	UX19A	9623638380	UC12A
74191	UC30A	GGP54	UC14A	9631658980	UC15A
		GGP56	UC4A	9633214380	UX20A
		GGP58	UX23A	5951881(FU2A)	UX20A
<b>FAI</b>	<b>MAGNETI MARELLI</b>	GGP59	UX16A	FU2A	UX20A
FG100	UX25A	GGP60	UX17A		
FG101	UX25A	GGP61	UX22A	<b>FORD</b>	<b>MAGNETI MARELLI</b>
FG104	UX20A	GGP62	UC8A	1008792	UX19A
FG106	UX20A	GGP64	UC11A	1056857	UX19A
FG107	UX20A	GGP65	UC21A	1079401	UC22A
FG108	UX20A	GGP66	UC40A	1148105	UY1A
FG110	UX20A	GGP67	UC12A	1313809	UC41A
FG111	UX20A	GGP69	UX20A	1690048	UC14A
FG114	UX11A	GGP72	UC45A	1952464	UC36A
FG116	UX7A	GGP74	UC26A	6154593	UX20A
FG121	UX11A				

<b>FORD</b>	
7072673	UX20A
7088988	UX11A
2S6Q6M090AA	UY1A
83BB6M090A1A	UX20A
83BB6M090A2A	UX20A
84BB6M090AA	UX20A
89FF6M090AA	UX11A
910X6M090AA	UX14A
93FF6M090AA	UX11A
96FF6M090AA	UX19A
96FF6M090AB	UX19A
96FF6M090BA	UX19A
96FF6M090BB	UX19A
99FF6M090AA	UX19A
EZD40	UY1A
V94DX6M090AA	UX20A
XS4U6M090AB	UC22A

<b>GM</b>	
09118201	UC16A

<b>HKT (KITAHARA)</b>	
B040	UX20A
CP02	UZ3A
CP07	UZ4A
CP50	UZ1A
CP51	UZ2A
PD191	UC38A
PI51	UC9A
PI57	UC9A
PI58	UC10A
PI59	UC9A
PN138	UC36A
PN81	UC11A
PN86	UC11A
PN86	UX20A
PN89	UX25A
PT145	UC38A
PT150	UC38A
PT152	UC38A

<b>HONDA</b>	
12291P5TG02	UC8A

<b>HYUNDAI</b>	
3671027000	UC33A
3671027010	UC33A

<b>ISUZU</b>	
8943197001	UC10A
8943197002	UC10A
8944819720	UC9A

<b>IVECO</b>	
98459883	UX11A

<b>LUCAS</b>	
DS001	UX20A
DS002	UX25A
DS003	UX20A
DS014	UX20A
DS052	UX7A
LP005	UX11A
LP022	UX25A
LP027	UC31A
LP033	UX20A
LP037	UC15A
LP040	UX17A
LP045	UX23A
LP048	UX19A
LP050	UC21A
LP055	UC17A
LP059	UC16A
LP062	UC30A
LP073	UC31A

<b>MAZDA</b>	
PN1118601	UZ5A

<b>MERCEDES</b>	
0001597501	UX20A
0001597701	UX20A
0001598101	UX20A

<b>MERCEDES</b>	
0001598301	UX20A
0001599601	UX20A
0001599901	UX20A
0011590201	UX20A
0011591501	UX16A
0011591601	UX16A
0011592001	UC17A
0011592101	UX17A
0011592701	UC18A
0011592801	UC17A
0011594901	UC17A
0011595001	UY8A
A0011595001	UY8A

<b>MITSUBISHI</b>	
MD197511	UZ4A

<b>MOPAR</b>	
4720600	UX20A
4863826	UC14A

<b>MOTORCRAFT</b>	
EZD10	UX25A
EZD11	UX20A
EZD13	UX7A
EZD14	UX20A
EZD5	UX20A
EZD8	UX11A
EZDA	UX25A
EZDB	UX20A
EZDD	UX7A
EZDE	UX20A

<b>NGK</b>	
A14T	UC10A
CY02	UZ3A
CY03	UZ1A
CY07	UZ4A
CY08	UC36A
CY51	UC36A
CY51	UC01F



NGK	MAGNETI MARELLI	NGK	MAGNETI MARELLI	NGK	MAGNETI MARELLI
CY52	UZ3A	DP8	UZ1A	Y739R	UC37A
CY53	UZ1A	DP9	UC15A	Y740	UC8A
CY57	UZ4A	Y1032	UC11A	Y740U	UC8A
CY58	UC36A	Y1032	UX20A	Y741U	UC14A
CZ101	UC01F	Y147T	UC38A	Y742U	UC10A
CZ22	UZ2A	Y207T	UX25A	Y743U	UC9A
DP1	UX20A	Y208T	UX20A	Y745U	UC17A
DP10	UC15A	Y501U	UC45A	Y746J	UC18A
DP11	UC17A	Y502R	UC37A	Y746R	UC18A
DP12	UC30A	Y503J	UC15A	Y747U	UC11A
DP13	UZ4A	Y503R	UC15A	Y748U	UC16A
DP14	UC16A	Y504J	UC12A	Y749J	UC33A
DP15	UX14A	Y504R	UC12A	Y901R	UX25A
DP16	UX17A	Y506J	UC21A	Y902R	UX20A
DP17	UC8A	Y506R	UC21A	Y908R	UX20A
DP18	UC31A	Y507J	UC26A	Y909R	UX7A
DP19	UX22A	Y507R	UC26A	Y910J	UX11A
DP2	UX25A	Y515J	UC31A	Y910R	UX11A
DP20	UC14A	Y516J	UC30A	Y911J	UX11A
DP21	UZ4A	Y517J	UC29A	Y911R	UX11A
DP22	UC8A	Y519J	UX24A	Y913J	UX14A
DP23	UX11A	Y523J	UC28A	Y913M	UX14A
DP24	UC12A	Y524J	UC22A	Y914U	UX20A
DP25	UX25A	Y525J	UC27A	Y917U	UX20A
DP26	UC11A	Y531J	UC35A	Y918J	UX25A
DP27	UC22A	Y532J	UC38A	Y918R	UX25A
DP28	UC9A	Y534J	UC19A	Y920R	UX20A
DP29	UC4A	Y541J	UZ2A	Y922R	UX20A
DP3	UX11A	Y547AS	UC02F	Y923U	UX20A
DP30	UX16A	Y703R	UC38A	Y924J	UX20A
DP31	UC45A	Y710R	UC10A	Y924U	UX20A
DP32	UC26A	Y711J	UC9A	Y925J	UX17A
DP33	UX11A	Y711RS	UC9A	Y925R	UX17A
DP34	UC24A	Y712RS	UC36A	Y925U	UC17A
DP35	UC27A	Y721RS	UC9A	Y927J	UX22A
DP36	UC19A	Y729U	UC24A	Y927R	UX22A
DP37	UC28A	Y730U	UC8A	Y928U	UC4A
DP38	UC18A	Y731U	UC15A	Y929U	UX23A
DP4	UC31A	Y732J	UC31A	Y930U	UX16A
DP5	UX19A	Y732U	UC31A	Y930Y	UX16A
DP7	UC21A	Y738U	UC40A	Y932R	UX25A

NGK	MAGNETI MARELLI
Y933J	UX25A
Y933R	UX25A
Y935U	UX11A
Y937J	UX19A
Y937R	UX19A
Y938R	UX20A
YE04	UY1A
YE05	UY5A

NIPPARTS	MAGNETI MARELLI
J5174002	UC8A
J5711016	UZ3A
J5711026	UX24A
J5711028	UC15A
J5711031	UC29A
J5712015	UC35A
J5712016	UC38A
J5713000	UZ5A
J5714000	UC8A
J5718000	UX20A
J5718001	UY2A
J5719009	UC9A

NISSAN	MAGNETI MARELLI
110650W801	UC36A
1106531N00	UC36A
110655C900	UZ3A
1106565N01	UC36A
110657C000	UC36A
110659C600	UC36A
11065AD200	UX24A
11065AD201	UX24A
11065AD210	UX24A
11065AD220	UX24A
11065G2400	UC36A

OPEL	MAGNETI MARELLI
1214033	UX20A
1214043	UZ1A
1214062	UZ2A
1214305	UX20A

OPEL	MAGNETI MARELLI
1214305	UX20A
1214306	UX20A
1214307	UX20A
1214310	UC9A
1214311	UC10A
1214312	UC10A
1214317	UX20A
1214319	UX20A
1214427	UC14A
1214457	UC16A
4403145	UX11A
5614216	UX25A
5614218	UX20A
5614219	UX25A
9118201	UC16A
88900715	UC17A
88900716	UC14A
88900717	UC45A
88900718	UC18A
88900720	UX19A
88900721	UC26A
88900722	UC31A
88900723	UX25A
88900724	UX16A
88900725	UX20A
88900726	UC15A
88900727	UX17A
88900728	UX20A
88900729	UC4A
88900731	UX20A
88900733	UX20A
88900736	UX20A
88900737	UX11A
88900738	UX20A
88900740	UX14A
88900743	UC10A
90166155	UX20A
90210824	UX20A
90487858	UX20A
90569338	UC16A
91153919	UC14A

OPEL	MAGNETI MARELLI
94481972	UC9A
12 14 033	UC28A
12 14 305	UC28A
91 196 669	UC28A
93 178 225	UC28A
97 464 737	UC28A

PEUGEOT	MAGNETI MARELLI
5960,78	UY5A
596012	UY1A
596064	UC41A
596065	UC41A
596139	UX20A
596153	UX20A
596157	UX20A
596235	UX20A
596274	UX20A
9152184980	UX20A
9153664680	UX20A
9616572480	UX20A
59622Y	UC15A
59623C	UC12A
59623H	UX20A
5962J2	UX14A
5962J5	UX20A
5962J6	UX20A
5962J7	UX25A
5962K5	UX20A
5962R8	UX20A
5962S8	UX20A
5962T7	UX11A
5962W3	UC15A

QUINTON HAZELL	MAGNETI MARELLI
QGP111	UX14A
QGP111	UX20A
QGP112	UX25A
QGP113	UX7A
QGP147	UX11A
QGP154	UC4A
QGP154	UX14A

QUINTON HAZELL	MAGNETI MARELLI
QGP154	UX20A
QGP155	UC31A
QGP163	UC10A
QGP169	UC9A
QGP174	UC24A
QGP175	UC15A
QGP178	UX19A
QGP179	UC8A
QGP181	UX25A

RENAULT	MAGNETI MARELLI
7700100558	UC21A
7700100586	UC8A
7700100635	UC30A
7700105290	UX22A
7700111323	UC31A
7700111940	UC30A
7700854538	UX25A
7700855865	UX14A
7700856238	UX14A
7700856292	UX25A
7700860796	UC8A
7700861906	UC8A
7700867002	UX22A
7700867617	UX25A
7700874336	UX22A
7701040208	UX11A
7701349943	UX14A
7701349949	UX25A
7701414072	UX20A
7701414077	UX25A
7701414080	UX20A
7701414081	UX11A
7701414086	UX20A
7701414088	UX25A
7701414108	UX20A
7701414123	UX20A
8200787721	UC30A
82000012099	UC29A

ROVER	MAGNETI MARELLI
ETC8847	UC24A
NCC100050	UC8A

SEAT	MAGNETI MARELLI
X03965520	UX20A

SUZUKI	MAGNETI MARELLI
09900-TD001	UX20A
09900-TD001-000	UX20A
18550-66G00	UX20A
18550-66G00-000	UX20A
1855067G00000	UC12A
1855067G10000	UC12A
1855067G11000	UC12A
1855073J00000	UY1A
1855084A00000	UC31A
1855084A50000	UC31A
1855084A51000	UC31A
1855084CT0000	UC30A

TOYOTA	MAGNETI MARELLI
1985027010	UC35A
1985030010	UC35A
1985064030	UC38A
1985064031	UC38A

UNIPART	MAGNETI MARELLI
GGP1	UX20A
GGP15	UC10A
GGP16	UC9A
GGP17	UX25A
GGP18	UX20A
GGP22	UX20A
GGP23	UC15A
GGP24	UC8A
GGP25	UC31A
GGP26	UC4A
GGP27	UX16A
GGP28	UX14A
GGP30	UX17A
GGP31	UC24A

UNIPART	MAGNETI MARELLI
GGP32	UX25A
GGP8	UX11A

VALEO	MAGNETI MARELLI
344876	UX25A
344877	UX20A
344879	UX7A
344882	UX11A
344883	UX20A
344884	UX20A
344885	UX11A
344887	UX20A
344894	UC4A
344894	UX20A
344895	UC15A
344896	UX20A
344917	UC10A
344918	UC9A
344921	UC8A
344922	UX20A
344932	UX20A
344953	UX20A
344955	UX19A
344957	UX16A
344959	UX17A
344961	UC21A
344964	UC16A
344967	UC8A
344972	UC11A
344973	UC31A
344986	UC17A
344988	UC18A
344991	UC26A
344993	UC29A
345005	UC22A
C100S	UX20A
C101S	UX20A
C102S	UX20A
C103S	UX7A
C105S	UX11A
C106S	UX20A

VALEO	MAGNETI MARELLI
C107S	UX20A
C108S	UX11A
C110S	UX20A
C111R	UX20A
C116S	UC10A
C117S	UC9A
C118S	UX25A
C200S	UX25A
C204R	UX20A
C205R	UC31A
C206R	UC4A
C206R	UX20A
C207R	UC15A
C208R	UX20A
C208R	UX20A
C210S	UC8A
C213S	UC8A
C215S	UX20A
C217S	UX19A
C219S	UX16A
C221S	UX17A
C223S	UC21A
C226S	UC16A
C227S	UC11A
C228S	UC31A
C236S	UC17A
C241S	UC26A
C243S	UC29A
C255S	UC22A

VOLKSWAGEN	MAGNETI MARELLI
N10140101	UC31A
N10140102	UC31A
N10140103	UC31A
N10140104	UC31A
N10140105	UC31A
N10213001	UX25A
N10213002	UX25A
N10579202	UC14A
N10591602	UC01F
N10591603	UC01F
N10591604	UC01F

VOLVO	MAGNETI MARELLI
1257889	UX25A
8653698	UC41A
N10579802	UC03F

VOLKSWAGEN	MAGNETI MARELLI
10140105	UC31A
059963319	UC45A
061905061	UX25A
068905061	UX25A
N0190814	UX25A
N0190971	UX25A
N0191001	UX25A
N0191002	UX25A
N0191005	UX25A
N0191006	UX25A

